



---

**TPC Benchmark<sup>TM</sup> H**  
**Full Disclosure Report**  
**DELL PowerEdge 6600/3.0GHz/4M**  
**Using**  
**Red Hat Enterprise Linux AS Version 3.0**  
**And**  
**Oracle Database 10g Enterprise Edition with RAC**



**First Edition**

**Submitted for Review**

**September 10, 2004**

Dell Computer Corp PowerEdge 6600 Server with Red Hat Enterprise Linux AS version 3.0 and Oracle Database 10g Enterprise Edition with RAC

First Printing September 2004

All rights reserved. Permission is hereby granted to reproduce this document in whole or in part provided the copyright notice is included on the title page of each item reproduced.

Printed in U.S.A.

DELL believes that the technical, pricing and discounting information in this document is accurate as of its publication date. The performance information in this document is for guidance only. System performance is highly dependent on many factors including system hardware, system and user software, and user-application characteristics. Customer applications must be carefully evaluated before estimating performance. DELL does not warrant or represent that a user can or will achieve similar performance as expressed in this document.

THE TERMS AND CONDITIONS GOVERNING THE SALE OF DELL HARDWARE PRODUCTS AND THE LICENSING OF DELL SOFTWARE CONSIST SOLELY OF THOSE SET FORTH IN THE WRITTEN CONTRACTS BETWEEN DELL AND ITS CUSTOMERS. NO REPRESENTATION OR OTHER AFFIRMATION OF FACT CONTAINED IN THIS DOCUMENT INCLUDING BUT NOT LIMITED TO STATEMENTS REGARDING PRICE, CAPACITY, RESPONSE-TIME PERFORMANCE, SUITABILITY FOR USE, OR PERFORMANCE OF PRODUCTS DESCRIBED HEREIN SHALL BE DEEMED TO BE A WARRANTY BY DELL FOR ANY PURPOSE, OR GIVE RISES TO ANY LIABILITY OF DELL WHATSOEVER.

DELL assumes no responsibility for any errors that may appear in this document. DELL reserves the right to make changes in specifications and other information contained in this document without prior notice, and the reader should in all cases consult DELL to determine whether any such changes have been made.

PowerEdge is an U.S. registered trademark of the DELL.

Oracle Database 10g is a registered trademark of Oracle Corporation.  
Red Hat Enterprise Linux is a registered trademark of Red Hat Inc.

Intel and Xeon MP are registered trademarks of Intel Corporation.

TPC Benchmark H is a trademark of the Transaction Processing Performance Council.

## Abstract

This report document the methodology and results of the TPC Benchmark H test conducted on a cluster of 2 PowerEdge 6600 Servers using Oracle database 10g in conformance with the requirements of the TPC-H Benchmark Specification. The operating system used for the benchmark was Red Hat Enterprise Linux Advanced Server 3.0.

<b>Hardware</b>	<b>Software</b>	<b>Total System Cost</b>
<b>2xDell PowerEdge 6600 with Quad 3.0GHz Intel Xeon MP Dell PowerVault 22XS Storage Enclosures</b>	<b>Oracle Database 10g Enterprise Edition Red Hat Enterprise Linux AS version 3.0</b>	<b>\$267,228</b>

<b>TPC-H Power@300GB</b>	<b>TPC-H Throughput@300GB</b>	<b>QphH@300GB</b>	<b>\$/QphH@300GB</b>
<b>8422.2</b>	<b>5483.3</b>	<b>6795.5</b>	<b>\$39.00</b>

The Transaction Processing Performance Council (TPC) developed the TPC-H Benchmark. The TPC was founded to define transactions processing benchmarks and to disseminate objective, verifiable performance data to the industry.

In order to verify compliance to the TPC-H benchmark specification, Lorna Livingtree, Performance Metrics, Inc., audited the benchmark configuration, environment and methodology used to produce and validate the test results, and the pricing model used to calculate the price/performance.



**DELL  
PowerEdge 6600  
with Oracle Database 10g**

**TPC-H Revision  
2.1.0**

Report Date:  
Sep 10, 2004  
Revision Date:  
Jan 11, 2005

**Total System Cost  
\$267,228**

**TPC-H Composite Query per Hour  
6795.5 QphH@300GB**

**Price/Performance  
\$39/QphH@300GB**

**Database Size  
300GB**

**Database Manager  
Oracle Database 10g Enterprise  
Edition with RAC and Partitioning**

**Operating System  
Red Hat Enterprise Linux  
AS v3.0**

**Other Software**

**Availability Date  
Sep 10, 2004**

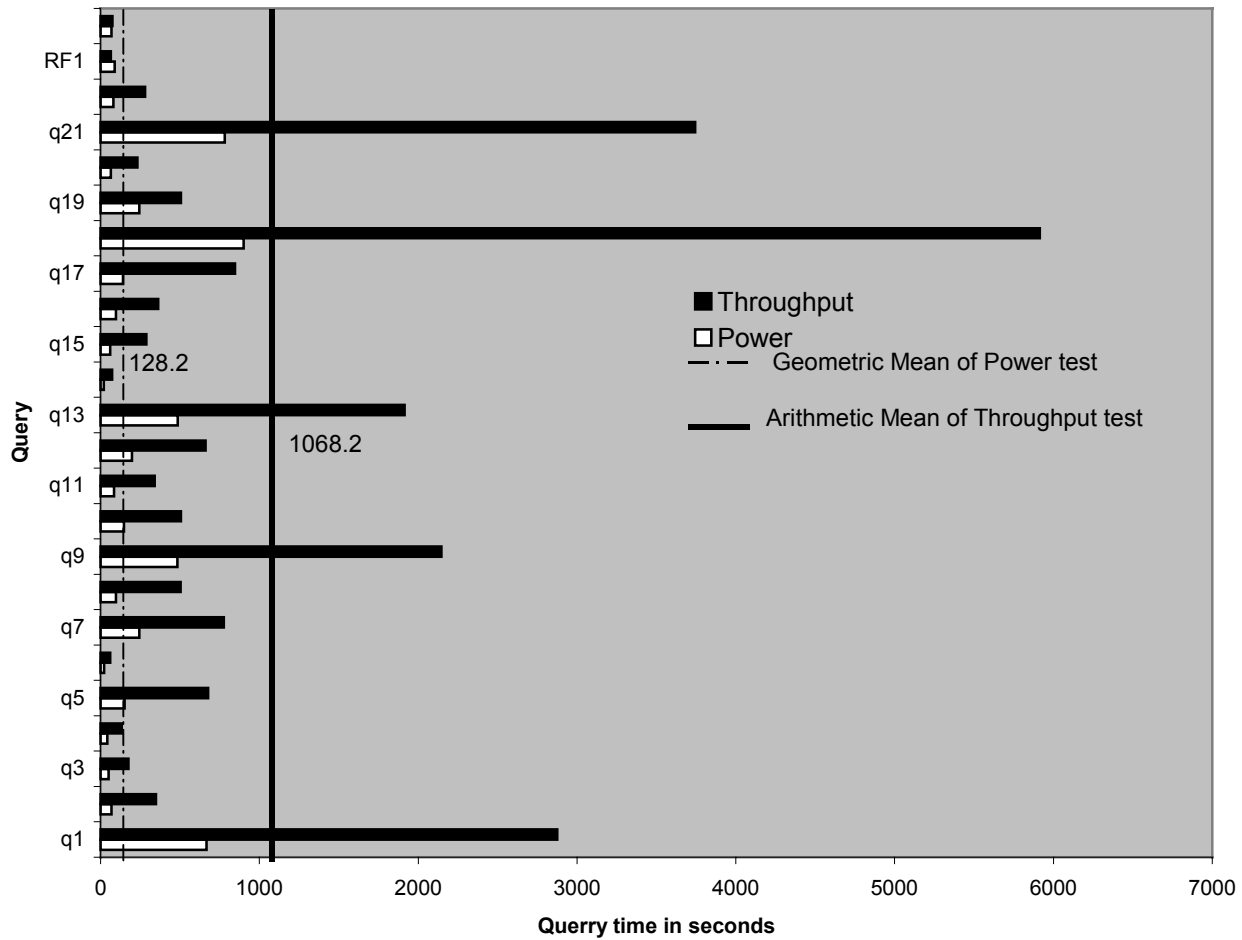

**Database Load Time  
7:07:29**

**Total Disk/Database Size  
9.45**

**Load Includes Backup  
N**

**RAID (Base tables only)  
N**

**RAID (Base tables and auxiliary  
data structures)  
N**

**RAID (Everything)  
Y**

**System Configuration :** 2 nodes  
**Processors (per node) :** 4x 3.0GHz/512kB L2/4MB L3 Intel Xeon MP  
**Memory (per node) :** 16GB RAM  
**Disk Drives:** 4 – 36GB 15k HDD  
 160 – 18GB 15k HDD

“Database Size includes only raw data (e.g., no temp, index, redundant storage space, etc.)”

Dell		PowerEdge 6600			TPC-H EXECUTIVE SUMMARY PAGE 2 OF 4		
					Report Date: 10-Sep-04		
		Client/Server			Revision Date: 11-Jan-05		
Description	Part Number	Third Party	Unit Price	Qty	Extended Price	3 yr. Maint. Price	
<b>Server Hardware</b>							
<b>Brand Pricing</b>							
Dell PowerEdge 6600	220-4646	1	6,366	2	12,732	1,299	
Intel Xeon MP 3.0GHz / 4MB L2 - 4 processors	311-3526	1	14,999	2	29,998	-	
16 GB,DDR	311-3852	1	8,799	2	17,598	-	
36 GB U320M SCSI 10K RPM Hard Drive	340-7919	1	249	4	996	-	
Dual on-board NICs	430-8991	1	0	0	-	-	
Cross-over cable	E5DD-C407	3	2	3	5	-	
Dell 15" Monitor	320-2907	1	135	2	270	-	
PERC4-DC 128MB U320 SCSI RAID controller	340-8157	1	879	16	14,064	0	
<b>Subtotal</b>					<b>75,663</b>	<b>1,299</b>	
<b>PowerVault Disk Subsystem</b>							
PV220S, U3 SCSI, PS, Rack mount	220-4476, etc.	1	1,717	16	27,472	9,600	
2x4M,PERC/39160 SCSI Cables	310-0679	1	99	16	1,584	-	
18 GB SCSI 15K RPM Hard Drive *	340-9472	1	249	160	39,840	-	
42U Rack	220-4492	1	964	2	1,928	-	
<b>Subtotal</b>					<b>70,824</b>	<b>9,600</b>	
<b>Server Software</b>							
Oracle Database 10g Enterprise Ed., 3yrs, Named User Plus		2	10,000	8	80,000		
Partitioning for 3yrs, Named User Plus		2	2,500	8	20,000		
Real Application Clusters for 3yrs, Named User Plus		2	5,000	8	40,000		
Oracle Database server support package per server for 3yrs		2	6,000	2		12,000	
Oracle Mandatory E-Business Discount		2			(\$22,800)	0	
Red Hat Enterprise Linux Advanced Server, 3yrs SUB NFI	420-4250	1	2,699	2	5,398	0	
<b>Subtotal</b>					<b>122,598</b>	<b>12,000</b>	
<b>Other Discounts</b>					<b>(24,756)</b>	<b>-</b>	
<b>Total</b>					<b>244,329</b>	<b>22,899</b>	
Notes: * Maint. included in PowerVault 220S disk pod or PV650F/630F fibre channel disk pod					<b>Three-Year Cost of Ownership: \$267,228</b>		
*** 10% or minimum 2 spares are added in place of onsite service (products have a five year return-to-vendor warranty) Pricing: 1 - Dell 2 - Oracle 3 - GreatCables.com					<b>QphH Rating: 6795.50</b>		
**** Discount based upon total system cost as purchased by a regular customer. Pricing may be verified by calling 1-800-BUY-DELL referencing quote numbers 173447236 as complex quotes.							
<b>Audited by Lorna Livingtree, Performance Metrics Inc.</b>					<b>\$ / QphH: 39</b>		
<i>Prices used in TPC benchmarks reflect the actual prices a customer would pay for a one-time purchase of the stated components. Individually negotiated discounts are not permitted. Special prices based on assumptions about past or future purchases are not permitted. All discounts reflect standard pricing policies</i>							



**DELL**  
**PowerEdge 6600**

**TPC-H Revision**  
**2.1.0**

**Report Date:**  
**Sep 10, 2004**  
**Revision Date:**  
**Jan 11, 2005**

## Numerical Quantities Summary

### Measurement Results:

Database Scale Factor	300
Total Data Storage/Database Size	9.45
Start of Database Load	8/31/2004 21:22:31
End of Database Load	9/01/2004 04:27:51
Database Load Time	7:05:20
Query Streams for Throughput Test	6
TPC-H Power	8422.2
TPC-H Throughput	5483.3
TPC-H Composite Query-per-Hour Metric (QpH@300GB)	6795.5
Total System Price Over 3 Years	\$267,228
TPC-H Price Performance Metric (\$/QpH@300GB)	\$39

### Measurement Interval:

Measurement Interval in Throughput Test (Ts) = 25999.1 seconds

### Duration of stream execution:

	Seed	Start Date/Time	End Date/Time	Duration
<b>Stream00</b>	901042751	9/01/2004 21:50:38	9/01/2004 23:16:06	1:25:28
<b>Stream01</b>	901042752	9/01/2004 23:17:16	9/02/2004 05:19:29	6:02:13
<b>Stream02</b>	901042753	9/01/2004 23:17:16	9/02/2004 06:16:06	6:58:50
<b>Stream03</b>	901042754	9/01/2004 23:17:16	9/02/2004 05:58:27	6:41:11
<b>Stream04</b>	901042755	9/01/2004 23:17:16	9/02/2004 06:15:37	6:58:21
<b>Stream05</b>	901042756	9/01/2004 23:17:16	9/02/2004 04:33:29	5:16:13
<b>Stream06</b>	901042757	9/01/2004 23:17:16	9/02/2004 06:16:41	6:59:25
<b>Refresh00</b>		9/01/2004 21:49:10	9/01/2004 21:50:38	0:01:28
		9/01/2004 23:16:06	9/01/2004 23:17:14	0:01:08
<b>Refresh01</b>		9/02/2004 06:16:41	9/02/2004 06:18:55	0:02:14
<b>Refresh02</b>		9/02/2004 06:18:55	9/02/2004 06:21:22	0:02:27
<b>Refresh03</b>		9/02/2004 06:21:22	9/02/2004 06:23:38	0:02:16
<b>Refresh04</b>		9/02/2004 06:23:38	9/02/2004 06:25:58	0:02:20
<b>Refresh05</b>		9/02/2004 06:25:58	9/02/2004 06:28:17	0:02:19
<b>Refresh06</b>		9/02/2004 06:28:17	9/02/2004 06:30:35	0:02:18



**DELL**  
**PowerEdge 6600**

**TPC-H Revision**  
**2.1.0**

**Report Date:**  
**Sep 10,2004**  
**Revision Date:**  
**Jan 11,2005**

## Numerical Quantities Summary

### Timing Intervals in Seconds:

Query	Q1	Q2	Q3	Q4	Q5	Q6	Q7	Q8
Stream00	666.1	68.9	50.2	42.4	150.1	22.1	244.1	96.9
Stream01	2327.2	381.6	86.1	122.9	714.0	33.4	852.3	517.9
Stream02	3348.2	376.5	106.8	73.3	654.8	109.8	891.2	551.8
Stream03	3225.7	344.4	74.3	172.7	836.6	116.7	939.0	598.5
Stream04	2746.6	342.6	53.4	131.6	545.2	43.2	325.0	499.8
Stream05	2848.7	375.7	128.2	142.6	610.6	33.2	665.7	411.7
Stream06	2761.1	274.4	604.1	155.9	699.2	27.2	985.5	442.7
Min Qi	2327.2	274.4	53.4	73.3	545.2	27.2	325.0	411.7
Max Qi	3348.2	381.6	604.1	172.7	836.6	116.7	985.5	598.5
Avg Qi	2876.2	349.2	175.5	133.2	676.7	60.6	776.4	503.7
Query	Q9	Q10	Q11	Q12	Q13	Q14	Q15	Q16
Stream00	482.9	148.1	83.7	197.5	486.3	20.1	60.5	96.8
Stream01	1945.1	463.1	353.9	702.5	1967.0	42.2	192.6	381.2
Stream02	2459.1	532.7	217.5	1085.8	1847.0	238.8	203.9	279.6
Stream03	1934.5	505.6	348.8	636.8	1225.8	52.8	185.4	283.7
Stream04	2758.2	543.3	333.7	387.5	1462.6	36.4	151.2	474.1
Stream05	1891.9	494.6	305.0	714.1	1919.0	38.5	286.4	371.6
Stream06	1882.0	492.1	490.1	437.8	3066.6	27.1	714.5	382.1
Min Qi	1882.0	463.1	217.5	387.5	1225.8	27.1	151.2	279.6
Max Qi	2758.2	543.3	490.1	1085.8	3066.6	238.8	714.5	474.1
Avg Qi	2145.1	505.2	341.5	660.7	1914.7	72.6	289.0	362.1
Query	Q17	Q18	Q19	Q20	Q21	Q22	RF1	RF2
Stream00	140.9	900.6	244.2	63.8	781.0	81.0	88.3	68.3
Stream01	301.6	6754.2	432.6	291.8	2676.1	194.3	60.9	72.8
Stream02	2327.5	5822.3	403.1	197.9	3033.0	370.0	73.1	74.0
Stream03	1680.0	6197.9	748.1	241.9	3431.5	291.0	62.8	73.2
Stream04	219.2	6775.9	669.4	96.0	6395.6	110.9	64.0	75.7
Stream05	290.5	3843.0	389.9	295.3	2573.2	343.3	66.7	72.5
Stream06	254.8	6085.7	386.4	272.1	4348.2	375.7	64.1	73.7
Min Qi	219.2	3843.0	386.4	96.0	2573.2	110.9	60.9	72.5
Max Qi	2327.5	6775.9	748.1	295.3	6395.6	375.7	73.1	75.7
Avg Qi	845.6	5913.1	504.9	232.5	3743.0	280.9	65.3	73.7

## Table of Contents

<b>General Items</b> .....	<b>1</b>
Test Sponsor.....	1
Parameter Settings.....	1
Configuration Items.....	1
<b>Clause 1: Logical Database Design</b> .....	<b>4</b>
Table Definitions.....	4
Physical Organization of Database .....	4
Horizontal Partitioning .....	4
Replication .....	4
<b>Clause 2: Queries and Update Functions</b> .....	<b>5</b>
Query Language .....	5
Random Number Generation .....	5
Substitution Parameters Generation .....	5
Query Text and Output Data from Database.....	5
Query Substitution Parameters and Seeds Used.....	5
Isolation Level .....	5
Refresh Function Source Code .....	5
<b>Clause 3: Database System Properties</b> .....	<b>7</b>
Atomicity.....	7
Completed Transaction.....	7
Aborted Transaction.....	7
Consistency.....	7
Consistency Test .....	7
Isolation.....	8
Read-Write Conflict with Commit .....	8
Read-Write Conflict with Rollback.....	8
Write-Write Conflict with Commit .....	8
Write-Write Conflict with Rollback .....	8
Concurrent Read and Write Transactions on Different Tables.....	9
Update Transactions During Continuous Read-Only Query Stream.....	9
Durability .....	9
Failure of a Durable Medium.....	9
System Crash .....	10
Memory Failure.....	10
<b>Clause 4: Scaling and Database Population</b> .....	<b>11</b>
Initial Cardinality of Tables .....	11
Distribution of Tables and Logs Across Media .....	11
Partitioning and Replication.....	19



RAID Implementations .....	19
DBGEN Version and Modifications.....	19
Database Load time .....	20
Data Storage Ratio.....	20
Database Load Mechanism Details and Illustration.....	20
<b>Clause 5: Performance Metrics and Execution Rules .....</b>	<b>22</b>
Steps in the Power Test .....	22
Timing Intervals .....	22
Number of Streams for The Throughput Test.....	22
Start/Finish Time of Each Query Stream.....	22
Total Elapsed Time .....	22
Start/Finish Time for Update Function.....	22
Timing Intervals for Each Query and Each Update .....	22
Performance Metrics .....	23
Reproducibility Method.....	23
System Activity Between Run1 and Run2 .....	23
<b>Clause 6: SUT and Driver Implementation .....</b>	<b>24</b>
Driver.....	24
Implementation Specific Layer (ISL).....	24
Profile-Directed Optimization.....	18
<b>Clause 7: Pricing .....</b>	<b>25</b>
Hardware and Software Used in the Priced System.....	25
Total Three Year Price .....	25
Availability Date.....	25
<b>Clause 8: Auditor-Related Items .....</b>	<b>26</b>
Auditor's Report .....	26
<b>Appendix A: Parameter settings .....</b>	<b>A</b>
<b>Appendix B: Database Build Scripts.....</b>	<b>B</b>
<b>Appendix C: ACID Scripts.....</b>	<b>C</b>
<b>Appendix D: Query text and Output.....</b>	<b>D</b>
<b>Appendix E: Seed and Input Parameters.....</b>	<b>E</b>
<b>Appendix F: Benchmark Scripts .....</b>	<b>F</b>
<b>Appendix G: Price Quotations.....</b>	<b>G</b>



# General Items

## Test Sponsor

*A statement identifying the benchmark sponsor(s) and other participating companies must be provided.*

DELL is the sponsor of this TPC Benchmark™ H result.

## Parameter Settings

*Settings must be provided for all customer-tunable parameters and options that have been changed from the defaults found in actual products, including but not limited to:*

- *Database Tuning Options*
- *Optimizer/Query execution options*
- *Query processing tool/language configuration parameters*
- *Recovery/commit options*
- *Consistency/locking options*
- *Operating system and configuration parameter*
- *Configuration parameters and options for any other software in the pricing structure*
- *Compiler optimization options*

*Providing a full list of all parameters and options can satisfy this requirement, as long as all those that have been modified from their default values have been clearly identified and these parameters and options are only set once.*

**Comment 1:** *In the event that some parameters and options are set multiple times, it must be easily discernible by an interested reader when the parameter or option was modified and what new value it received each time.*

**Comment 2:** *This requirement can be satisfied by providing a full list of all parameters and options, as long as all those that have been modified from their default values have been clearly identified and these parameters and options are only set once.*

Details of system and database configurations and parameters are provided in Appendix A.

## Configuration Items

*Diagrams of both measured and priced configurations must be provided, accompanied by a description of the differences. This includes, but is not limited to:*

- *Number and type of processors*
- *Size of allocated memory, and any specific mapping/partitioning of memory in the test.*
- *Number and type of disk units (and controllers, if applicable).*
- *Number of channels or bus connections to disk units, including their protocol type.*
- *Number of LAN (e.g. Ethernet) Connections, including routers, workstations, terminals, etc., that were physically used in the test or are incorporated into the pricing structure.*

- *Type and the run-time execution location of software components (e.g., DBMS, query processing tools/languages, middle-ware components, software drivers, etc.).*

The System Under Test (SUT), 2x DELL PowerEdge 6600 Servers, depicted in the next diagram consists of:

- 8 - 3.0GHz Intel ® Xeon MP Processors, each with 4MB of L3 cache.
- 32GB RAM.
- 16 - DELL PERC4-DC RAID Controllers, each with 128MB RAM of cache.
- 16 - DELL PowerVault 22XS.
- 160 – 18GB,U320 15k SCSI
- 4 – 36GB 10k HDD.

Per *Clause 7.1.1*:

*Specifically excluded from the priced system calculation are:*

- *End-user communication devices and related cables, connectors, and concentrators;*
- *Equipment and tools used exclusively in the production of the full disclosure report;*
- *Equipment and tools used exclusively for the execution of the DBGEN or QGEN (see Clause 2.1.4 and Clause 4.2.1) programs.*

## Measured and Priced Configuration

The measured and priced configurations are the same.

### PE6600A

4xIntel Xeon MP 3.0GHz/4MB-L3  
16 GB DDR  
8xPERC4-DC Controllers  
2x10Gb U160 15K SCSI

### DBMS

Oracle 10g w/ RAC

### OS

Red Hat Linux AS 3.0 w/  
2.4.21-15.ELsmp kernel

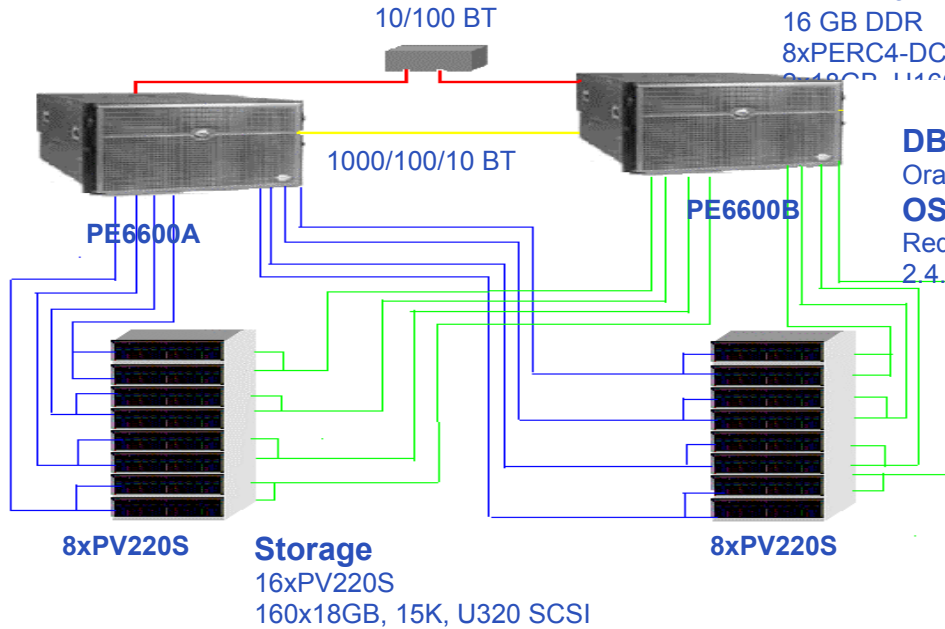

### PE6600B

4xIntel Xeon MP 3.0GHz/4MB-L3  
16 GB DDR  
8xPERC4-DC Controllers  
2x10Gb U160 15K SCSI

### DBMS

Oracle 10g w/ RAC

### OS

Red Hat Linux AS 3.0 w/  
2.4.21-15.ELsmp kernel

# Clause 1: Logical Database Design

## Table Definitions

*Listings must be provided for all table definition statements and all other statements used to set up the test and qualification databases.*

Appendix B contains the scripts that create and analyze the tables and indexes for the TPC-H database.

## Physical Organization of Database

*The physical organization of tables and indices, within the test and qualification databases, must be disclosed. If the column ordering of any table is different from that specified in Clause 1.4, it must be noted.*

No record clustering or index clustering was used for this benchmark. Column ordering was reordered in tables. Refer to the table create statements in Appendix B for further details.

## Horizontal Partitioning

*Horizontal partitioning of tables and rows in the test and qualification databases (see Clause 1.5.4) must be disclosed.*

Horizontal partitioning was used for all base and index tables except NATION and REGION. The details of this partitioning can be understood by examining the syntax of the table and index definition statements in Appendix B. Similar partitioning was used in the qualification database.

## Replication

*Any replication of physical objects must be disclosed and must conform to the requirements of Clause 1.5.6.*

Replication was not used for this benchmark.

## Clause 2: Queries and Update Functions

### Query Language

*The query language used to implement the queries must be identified.*

SQL was the query language used to implement all queries.

### Random Number Generation

*The method of verification for the random number generation must be described unless the supplied DBGEN and QGEN were used.*

Version 1.3.0 of DBGEN and version 1.3.0 of QGEN were used to generate the random numbers for this TPC-H benchmark.

### Substitution Parameters Generation

*The method used to generate values for substitution parameters must be disclosed. If QGEN is not used for this purpose, then the source code of any non-commercial tool used must be disclosed. If QGEN is used, the version number, release number, modification number and patch level of QGEN must be disclosed.*

QGEN version 1.3.0 was used to generate the substitution parameters.

### Query Text and Output Data from Database

*The executable query text used for query validation must be disclosed along with the corresponding output data generated during the execution of the query text against the qualification database. If minor modifications (see Clause 2.2.3) have been applied to any functional query definitions or approved variants in order to obtain executable query text, these modifications must be disclosed and justified. The justification for a particular minor query modification can apply collectively to all queries for which it has been used. The output data for the power and throughput tests must be made available electronically upon request.*

Appendix D contains the query text and query output. The minor query modifications used in this implementation include the following:

### Query Substitution Parameters and Seeds Used

*All the query substitution parameters used during the performance test must be disclosed in tabular format, along with the seeds used to generate these parameters.*

Appendix E contains the seed and query substitution parameters.

### Isolation Level

*The isolation level used to run the queries must be disclosed. If the isolation level does not map closely to one of the isolation levels defined in Clause 3.4, additional descriptive detail must be provided.*

The queries and transactions were run with isolation level 3 (repeatable read).

## **Refresh Function Source Code**

*The details of how the refresh functions were implemented must be disclosed (including source code of any non-commercial program used).*

The source code for the refresh functions are included in Appendix F.



## Clause 3: Database System Properties

### Atomicity

*The results of the ACID tests must be disclosed along with a description of how the ACID requirements were met. This includes disclosing the code written to implement the ACID Transaction and Query.*

### Atomicity of Completed Transaction

*Perform the ACID Transaction for a randomly selected set of input data and verify that the appropriate rows have been changed in the ORDER, LINEITEM, and HISTORY tables.*

1. The total prices from the ORDER table and the extended price from the LINEITEM table were retrieved for a randomly selected order key.
2. The ACID Transaction was performed using the order key from step 1.
3. The ACID Transaction was committed.
4. The total price from the ORDER table and the extended price from the LINEITEM table were retrieved for the same order key. It was verified that the appropriate rows had been changed.

### Aborted Transaction

*Perform the ACID transaction for a randomly selected set of input data, substituting a ROLLBACK of the transaction for the COMMIT of the transaction. Verify that the appropriate rows have not been changed in the ORDER, LINEITEM, and HISTORY tables.*

1. The total price from the ORDER table and the extended price from the LINEITEM table were retrieved for a randomly selected order key.
2. The ACID Transaction was performed using the order key from step 1. The transaction was stopped prior to the commit.
3. The ACID Transaction was rolled back.
4. The total price from the ORDER table and the extended price from the LINEITEM table were retrieved for the same order key, and verified to not have changed.

### Consistency

*A consistent state for the TPC-H database is defined to exist when:*

$$O\_TOTALPRICE = SUM(trunc(trunc(L\_EXTENDEDPRICE *(1 - L\_DISCOUNT),2) * (1+L\_TAX),2)) \text{ for each ORDERS and LINEITEM defined by } (O\_ORDERKEY = L\_ORDERKEY)$$

### Consistency Test

*Verify that ORDER and LINEITEM tables are initially consistent, submit the prescribed number of ACID Transactions with randomly selected input parameters, and re-verify the consistency of the ORDER and LINEITEM tables.*

1. The consistency of the ORDER and LINEITEM tables was verified based on a sample of O\_ORDERKEYs.
2. 100 ACID transactions were submitted from each of 6 execution streams.
3. The consistency of the ORDER and LINEITEM tables was verified a second time with the same O\_ORDERKEYs.

## Isolation

*Operations of concurrent transactions must yield results which are indistinguishable from the results which would be obtained by forcing each transaction to be serially executed to completion in some order.*

### Read-Write Conflict with Commit

*Demonstrate isolation for the read-write conflict of a read-write transaction and a read-only transaction when the read-write transaction is committed.*

1. An ACID transaction was started for a randomly selected O\_KEY, L\_KEY, and DELTA. The ACID transaction was suspended prior to commit.
2. An ACID query was started for the same O\_KEY used in step 1. The ACID query completed and did not see the uncommitted changes made by the ACID transaction.
3. The ACID transaction was committed.

### Read-Write Conflict with Rollback

*Demonstrate isolation for the read-write conflict of a read-write transaction and a read-only transaction when the read-write transaction is rolled back.*

1. An ACID transaction was started for a randomly selected O\_KEY, L\_KEY, and DELTA. The ACID transaction was suspended prior to rollback.
2. An ACID query was started for the same O\_KEY used in step 1. The ACID query completed and did not see the uncommitted changes made by the ACID transaction.
3. The ACID transaction was rolled back.

### Write-Write Conflict with Commit

*Demonstrate isolation for the write-write conflict of two update transactions when the first transaction is committed.*

1. An ACID transaction, T1, was started for a randomly selected O\_KEY, L\_KEY, and DELTA. The ACID transaction was suspended prior to commit.
2. A second ACID transaction, T2, was started using the same O\_KEY and L\_KEY and a different randomly selected DELTA.
3. T2 waited.
4. T1 was allowed to commit and then T2 completed.
5. It was verified that T2.L\_EXTENDPRICE was calculated correctly.

### Write-Write Conflict with Rollback

*Demonstrate isolation for the write-write conflict of two update transactions when the first transaction is rolled back.*

1. An ACID transaction, T1, was started for a randomly selected O\_KEY, L\_KEY, and DELTA. The ACID transaction was suspended prior to rollback.
2. A second ACID transaction, T2, was started using the same O\_KEY and L\_KEY and a different randomly selected DELTA.
3. T2 waited.
4. T1 was allowed to rollback and then T2 completed.
5. It was verified that T2.L\_EXTENDPRICE was calculated correctly.

## **Concurrent Read and Write Transactions on Different Tables**

*Demonstrate the ability of read and write transactions affecting different database tables to make progress concurrently.*

The following steps were performed:

1. An ACID Transaction T1 for a randomly selected O\_KEY, L\_KEY and DELTA. The ACID Transaction T1 was suspended prior to Commit.
2. Another ACID Transaction T2 was started using random values for PS\_PARTKEY and PS\_SUPPKEY.
3. T2 completed.
4. T1 completed and the appropriate rows in the ORDER, LINEITEM and HISTORY tables were changed.

## **Update Transactions During Continuous Read-Only Query Stream**

*Demonstrate the continuous submission of arbitrary (read-only) queries against one or more tables of the database does not indefinitely delay update transactions affecting those tables from making progress.*

The following steps were performed:

1. An ACID Transaction T1 was started, executing Q1 against the qualification database. The substitution parameter was chosen from the interval [0..2159] so that the query ran for a sufficient amount of time.
2. Before T1 completed, an ACID Transaction T2 was started using randomly selected values of O\_KEY, L\_KEY and DELTA.
3. T2 completed before T1 completed.
4. It was verified that the appropriate rows in the ORDER, LINEITEM and HISTORY tables were changed.

## **Durability**

*The tested system must guarantee durability: the ability to preserve the effects of committed transactions and insure database consistency after recovery from any one of the failures listed in Clause 3.5.2.*

## **Failure of a Durable Medium**

*Guarantee the database and committed updates are preserved across a permanent irrecoverable failure of any single durable medium containing TPC-H database tables or recovery log tables.*

The database logs were stored on a RAID-10.

The tables for the database were stored on RAID-10 stripes.

During the test, one disk from the DELL PV220 enclosure containing data and re-do log files was removed. As all data and re-do log files resided on RAID 10 volumes, the test continued uninterrupted.

## **System Crash**

*Guarantee the database and committed updates are preserved across an instantaneous interruption (system crash/system hang) in processing which requires the system to reboot to recover.*

1. Six streams of ACID transactions were started.
2. While the streams of ACID transactions were running the system was powered off.
3. When power was restored the system rebooted and the database was restarted.
4. The database went through a recovery period.
5. The success file and the HISTORY table counts were compared, and they matched.

## **Memory Failure**

*Guarantee the database and committed updates are preserved across failure of all or part of memory (loss of contents).*

The system crash test and the memory failure test were combined. See the previous section.

## Clause 4: Scaling and Database Population

### Initial Cardinality of Tables

The cardinality (e.g., the number of rows) of each table of the test database, as it existed at the completion of the database load (see clause 4.2.5) must be disclosed.

#### *Initial number of rows*

Table	Occurrences
Orders	450,000,000
Lineitem	1,799,989,091
Customer	45,000,000
Part	60,000,000
Supplier	3,000,000
Partsupp	240,000,000
Nation	25
Region	5

### Distribution of Tables and Logs Across Media

The distribution of tables and logs across all media must be explicitly described.

The Oracle 10g Database was stored on a shared-storage system composed of the following:

- 16 x DELL PERC4-DC Disk Controllers
- 16 x PowerVault 22XS Disk Enclosures
- 160x 18GB,U320, 15k rpm, SCSI disk drives
- 4 x 36GB 10k rpm disk drives

16 logical volumes were configured each spanning 10 physical drives across both SCSI channels of the controller in a RAID10 formation. The PV220 disk enclosures and PERC4-DC controllers were configured for cluster-mode thereby enabling simultaneous storage access from both server nodes. Both nodes had 2 36GB, SCSI disks each for the operating system. Each logical volume had 2 Linux partitions except for volume1 and volume2, which had 3 partitions. Each logical volume had an ext2 Linux file system for flat file storage and a raw partition for the database files. Volume1 and Volume2 each had an extra raw partition for the Oracle Cluster Registry (OCR) and Voting disk respectively. The database raw partitions were configured into an Automatic Storage Management (ASM) disk group.

Oracle ASM transparently managed the placement of the database and log data onto the shared-storage system.

A detailed description of distribution of database file groups and log can be found below.

### Distribution of Storage

Red Hat Linux AS v3.0 Disk Administration			DELL PERC4-DC Configuration					
Disk 0 86390MB			Controller # 0					
Partition			Slot# 2		Channels			
1	2	3		SCSI ID	A	B		
/dev/sdc1 raw1 DB data 61891MB Raw FS	/dev/sdc2 raw17 OCR 150MB Raw FS	/dev/sdc3 ff1 Flat Files 24348MB Ext2 FS		0	A0-1	A1-1		
				1	A0-2	A1-2		
				2	A0-3	A1-3		
				3	A0-4	A1-4		
				4	A0-5	A1-5		
				5				
				8				
				9				
				10				
				11				
				12				
				13				
				14				
				15				

Red Hat Linux AS v3.0 Disk Administration			DELL PERC4-DC Configuration							
Disk 1 86390MB			Controller # 0							
Partition			Slot# 2		Channels					
1	2	3		SCSI ID	A	B				
/dev/sdd1 raw2 DB data 61891MB Raw FS	/dev/sdd2 raw18 Voting Disk 150MB Raw FS	/dev/sdd3 ff2 Flat Files 24348MB Ext2 FS		0						
				1						
				2						
				3						
				4						
				5						
				8						
				9			A0-6	A1-6		
				10			A0-7	A1-7		
				11			A0-8	A1-8		
				12			A0-9	A1-9		
				13			A0-10	A1-10		
				14						
				15						

Red Hat Linux AS v3.0 Disk Administration		DELL PERC4-DC Configuration			
Disk 0 86390MB		Controller # 1			
Partition		Slot# 3	Channels		
1	2	SCSI ID	A	B	
/dev/sde1 raw3 DB data 61891MB Raw FS	/dev/sde2 ff3 Flat Files 24498MB Ext2 FS	0	A0-1	A1-1	
		1	A0-2	A1-2	
		2	A0-3	A1-3	
		3	A0-4	A1-4	
		4	A0-5	A1-5	
		5			
		8			
		9			
		10			
		11			
		12			
		13			
		14			
		15			

Red Hat Linux AS v3.0 Disk Administration		DELL PERC4-DC Configuration			
Disk 1 86390MB		Controller # 1			
Partition		Slot# 3	Channels		
1	2	SCSI ID	A	B	
/dev/sdf1 raw4 DB data 61891MB Raw FS	/dev/sdf2 ff4 Flat Files 24498MB Ext2 FS	0			
		1			
		2			
		3			
		4			
		5			
		8			
		9	A0-6	A1-6	
		10	A0-7	A1-7	
		11	A0-8	A1-8	
		12	A0-9	A1-9	
		13	A0-10	A1-10	
		14			
		15			

Red Hat Linux AS v3.0 Disk Administration		DELL PERC4-DC Configuration			
Disk 0 86390MB		Controller # 2			
Partition		Slot# 6	Channels		
1	2	SCSI ID	A	B	
/dev/sdg1 raw5 DB data 61891MB Raw FS	/dev/sdg2 ff5 Flat Files 24498MB Ext2 FS	0	A0-1	A1-1	
		1	A0-2	A1-2	
		2	A0-3	A1-3	
		3	A0-4	A1-4	
		4	A0-5	A1-5	
		5			
		8			
		9			
		10			
		11			
		12			
		13			
		14			
		15			

Red Hat Linux AS v3.0 Disk Administration		DELL PERC4-DC Configuration			
Disk 1 86390MB		Controller # 2			
Partition		Slot# 6	Channels		
1	2	SCSI ID	A	B	
/dev/sdh1 raw6 DB data 61891MB Raw FS	/dev/sdh2 ff6 Flat Files 24498MB Ext2 FS	0			
		1			
		2			
		3			
		4			
		5			
		8			
		9	A0-6	A1-6	
		10	A0-7	A1-7	
		11	A0-8	A1-8	
		12	A0-9	A1-9	
		13	A0-10	A1-10	
		14			
		15			



Disk 0 86390MB		Controller # 3			
Partition		Slot# 4	Channels		
1	2	SCSI ID	A	B	
/dev/sdi1 raw7 DB data 61891MB Raw FS	/dev/sdi2 ff7 Flat Files 24498MB Ext2 FS	0	A0-1	A1-1	
		1	A0-2	A1-2	
		2	A0-3	A1-3	
		3	A0-4	A1-4	
		4	A0-5	A1-5	
		5			
		8			
		9			
		10			
		11			
		12			
		13			
		14			
		15			

Red Hat Linux AS v3.0 Disk Administration		DELL PERC4-DC Configuration			
Disk 1 86390MB		Controller # 3			
Partition		Slot# 4	Channels		
1	2	SCSI ID	A	B	
/dev/sdj1 raw8 DB data 61891MB Raw FS	/dev/sdj2 ff8 Flat Files 24498MB Ext2 FS	0			
		1			
		2			
		3			
		4			
		5			
		8			
		9	A0-6	A1-6	
		10	A0-7	A1-7	
		11	A0-8	A1-8	
		12	A0-9	A1-9	
		13	A0-10	A1-10	
		14			
		15			

Red Hat Linux AS v3.0 Disk Administration	DELL PERC4-DC Configuration
---	-----------------------------

Disk 0 86390MB		Controller # 4			
Partition		Slot# 5	Channels		
1	2	SCSI ID	A	B	
/dev/sdk1 raw9 DB data 61891MB Raw FS	/dev/sdk2 ff9 Flat Files 24498MB Ext2 FS	0	A0-1	A1-1	
		1	A0-2	A1-2	
		2	A0-3	A1-3	
		3	A0-4	A1-4	
		4	A0-5	A1-5	
		5			
		8			
		9			
		10			
		11			
		12			
		13			
		14			
		15			
		Red Hat Linux AS v3.0 Disk Administration		DELL PERC4-DC Configuration	
Disk 1 86390MB		Controller # 4			
Partition		Slot# 5	Channels		
1	2	SCSI ID	A	B	
/dev/sdl1 raw10 DB data 61891MB Raw FS	/dev/sdl2 ff10 Flat Files 24498MB Ext2 FS	0			
		1			
		2			
		3			
		4			
		5			
		8			
		9	A0-6	A1-6	
		10	A0-7	A1-7	
		11	A0-8	A1-8	
		12	A0-9	A1-9	
		13	A0-10	A1-10	
		14			
		15			
		Red Hat Linux AS v3.0 Disk Administration		DELL PERC4-DC Configuration	

Disk 0 86390MB		Controller # 5			
Partition		Slot# 10	Channels		
1	2	SCSI ID	A	B	
/dev/sdm1 raw11 DB data 61891MB Raw FS	/dev/sdm2 ff11 Flat Files 24498MB Ext2 FS	0	A0-1	A1-1	
		1	A0-2	A1-2	
		2	A0-3	A1-3	
		3	A0-4	A1-4	
		4	A0-5	A1-5	
		5			
		8			
		9			
		10			
		11			
		12			
		13			
		14			
		15			

Red Hat Linux AS v3.0 Disk Administration		DELL PERC4-DC Configuration			
Disk 1 86390MB		Controller # 5			
Partition		Slot# 10	Channels		
1	2	SCSI ID	A	B	
/dev/sdn1 raw12 DB data 61891MB Raw FS	/dev/sdn2 ff12 Flat Files 24498MB Ext2 FS	0			
		1			
		2			
		3			
		4			
		5			
		8			
		9	A0-6	A1-6	
		10	A0-7	A1-7	
		11	A0-8	A1-8	
		12	A0-9	A1-9	
		13	A0-10	A1-10	
		14			
		15			

Red Hat Linux AS v3.0 Disk Administration		DELL PERC4-DC Configuration			
Disk 0 86390MB		Controller # 6			

Partition		Slot# 8		Channels			
1	2		SCSI ID	A	B		
/dev/sdo1 raw13 DB data 61891MB Raw FS	/dev/sdo2 ff13 Flat Files 24498MB Ext2 FS		0	A0-1	A1-1		
			1	A0-2	A1-2		
			2	A0-3	A1-3		
			3	A0-4	A1-4		
			4	A0-5	A1-5		
			5				
			8				
			9				
			10				
			11				
			12				
			13				
			14				
			15				

Red Hat Linux AS v3.0 Disk Administration		DELL PERC4-DC Configuration						
Disk 1 86390MB		Controller # 6						
Partition		Slot# 8		Channels				
1	2		SCSI ID	A	B			
/dev/sdp1 raw14 DB data 61891MB Raw FS	/dev/sdp2 ff14 Flat Files 24498MB Ext2 FS		0					
			1					
			2					
			3					
			4					
			5					
			8					
			9		A0-6	A1-6		
			10		A0-7	A1-7		
			11		A0-8	A1-8		
			12		A0-9	A1-9		
			13		A0-10	A1-10		
			14					
			15					

Red Hat Linux AS v3.0 Disk Administration		DELL PERC4-DC Configuration					
Disk 0 86390MB		Controller # 7					
Partition		Slot# 9		Channels			
1	2		SCSI ID	A	B		

1	2		SCSI ID	A	B		
/dev/sdq1 raw15 DB data 61891MB Raw FS	/dev/sdq2 ff15 Flat Files 24498MB Ext2 FS		0	A0-1	A1-1		
			1	A0-2	A1-2		
			2	A0-3	A1-3		
			3	A0-4	A1-4		
			4	A0-5	A1-5		
			5				
			8				
			9				
			10				
			11				
			12				
			13				
			14				
			15				

Red Hat Linux AS v3.0 Disk Administration		DELL PERC4-DC Configuration						
Disk 1 86390MB		Controller # 7						
Partition		Slot# 9		Channels				
1	2		SCSI ID	A	B			
/dev/sdr1 raw16 DB data 61891MB Raw FS	/dev/sdr2 ff16 Flat Files 24498MB Ext2 FS		0					
			1					
			2					
			3					
			4					
			5					
			8					
			9		A0-6	A1-6		
			10		A0-7	A1-7		
			11		A0-8	A1-8		
			12		A0-9	A1-9		
			13		A0-10	A1-10		
			14					
			15					

## Partitioning and Replication

*The mapping of database partitions/replications must be explicitly described.*

The database was not replicated.

Horizontal partitioning was used for base tables tables except NATION and REGION.

## RAID Implementations

*Implementations may use some form of RAID to ensure high availability. If used for data, auxiliary storage (e.g. indexes) or temporary space, the level of RAID used must be disclosed for each device.*

RAID 10 was used for all tables, indexes, temp files, logs and flat files.

## DBGEN Version and Modifications

*The version number, release number, modification number, and patch level of DBGEN must be disclosed. Any modifications to the DBGEN (see Clause 4.2.1) source code....must be disclosed. In the event that a program other than DBGEN was used to populate the database, it must be disclosed in its entirety.*

The supplied DBGEN Version 1.3.0 was used for database population. No modifications were made to DBGEN.

## Database Load time

*The database load time for the test database (see clause 4.3) must be disclosed.*

Database load time was 7hours 5 minutes 20 seconds.

## Data Storage Ratio

*The data storage ratio must be disclosed. It is computed by dividing the total data storage of the priced configuration (expressed in GB) by the size chosen for the test database as defined in 4.1.3.1. The ratio must be reported to the nearest 1/100, rounded up.*

### Data Storage Ratio

Disk Type	Number of Disks	Space per Disk	Subtotal Disk Space	Total Disk Storage	Data Storage Ratio
18GB 15k	160	16.87GB	2699.69GB		
36GB 15k	4	33.92GB	135.68GB		
				2835.37GB	9.45

## Database Load Mechanism Details and Illustration

*The details of the database load must be disclosed, including a block diagram illustrating the overall process. Disclosure of the load procedure includes all steps, scripts, input and configuration files required to completely reproduce the test and qualification databases.*

DBGEN was used to create the flat files. The figure below describes the load procedure.

## Database Load Process

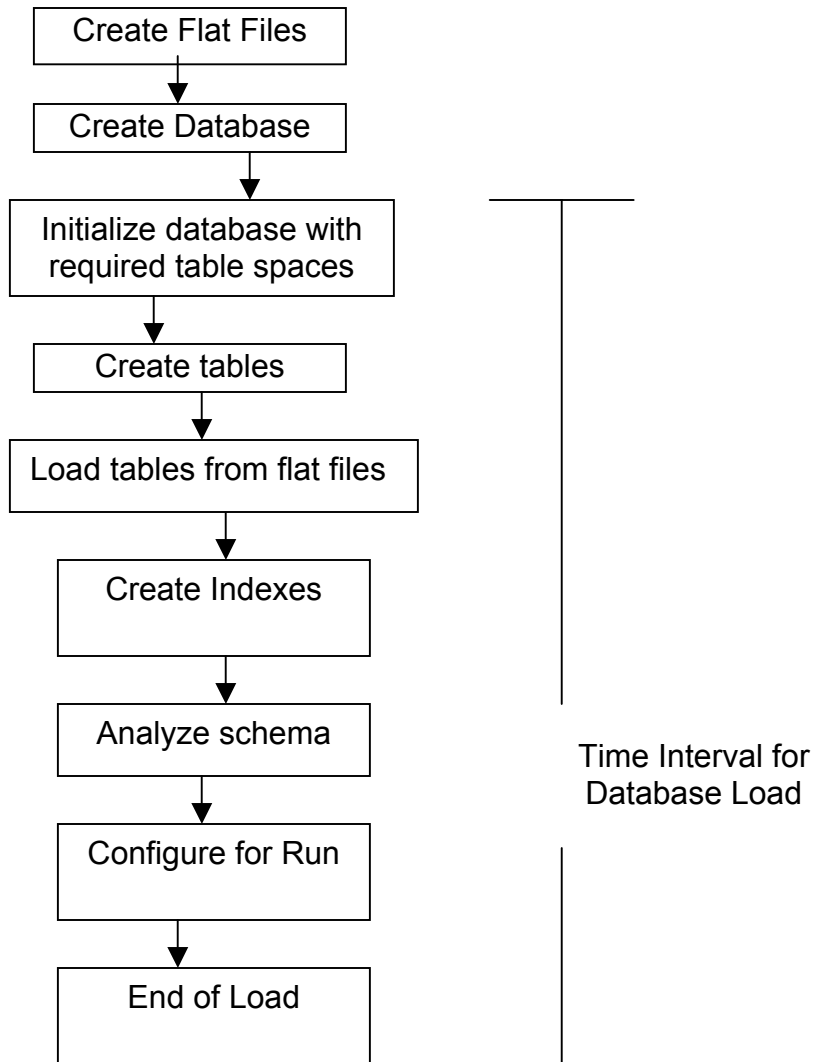

# Clause 5: Performance Metrics and Execution Rules

## Steps in the Power Test

*The details of the steps followed to implement the power test (e.g., system boot, database restart, etc.) must be disclosed.*

The following steps were used to implement the power test:

1. Database restart.
2. RF1 update transaction.
3. Stream 00 execution.
4. RF2 update transaction.

## Timing Intervals

*The timing intervals (see Clause 5.3.6) for each query of the measured set and for both update functions must be reported for the power test.*

The power test timing intervals are disclosed in the Numerical Quantities Summary at the beginning of this document.

## Number of Streams for The Throughput Test

*The number of execution streams used for the throughput test must be disclosed.*

Six streams were used for the throughput test.

## Start/Finish Time of Each Query Stream

*The start time and finish time for each query execution stream must be reported for the throughput test.*

The throughput test start time and finish time for each stream are disclosed in the Numerical Quantities Summary at the beginning of this document.

## Total Elapsed Time

*The total elapsed time of the measurement interval must be reported for the throughput test.*

The total elapsed time of the throughput test was 25,999.1 seconds.

## Start/Finish Time for Refresh Functions

*Start and finish time for each refresh function in the update stream must be reported for the throughput test.*

The start and finish time for each refresh function in the update stream are disclosed in the Numerical Quantities Summary at the beginning of this document.

## Timing Intervals for Each Query and Each Update

*The timing intervals (see Clause 5.3.6) for each query of each stream and for each update function must be reported for the throughput test.*



The timing intervals for each query and each update function are contained in the Numerical Quantities Summary disclosed earlier in this document.

## Performance Metrics

*The computed performance metrics, related numerical quantities and the price performance metric must be reported.*

The performance metrics, and the numbers, on which they are based, are contained in the Numerical Quantities section of the Executive Summary.

## Reproducibility Method

*A description of the method used to determine the reproducibility of the measurement results must be reported. This must include the performance metrics (QppH and QthH) from the reproducibility runs.*

Performance results from the first two executions of the TPC-H benchmark indicated the following percent differences for the metrics:

### ***Percentage Differences in Benchmark Executions***

<b>Run</b>	<b>QppH@300GB</b>	<b>QthH@300GB</b>	<b>QphH@300GB</b>
1	8,702.7	5370.9	6,836.7
2	8,422.2	5483.3	6,795.5
Percent Difference	-3.3%	2.0%	-0.6%

## System Activity Between Run1 and Run2

*Any activity on the SUT that takes place between the conclusion of Run1 and the beginning of Run2 must be disclosed.*

Database was restarted between Run1 and Run2.

## Clause 6: SUT and Driver Implementation

### Driver

*A detailed description of how the driver performs its functions must be supplied, including any related source code or scripts. This description should allow an independent reconstruction of the driver.*

A single script performs all stream executions. QGEN is used to produce query text.

For each power-test run:

- RF1 refresh updates are submitted to the database
- QGEN-generated queries are submitted in the order defined by Clause 5.3.5.4
- RF2 refresh updates are submitted to the database

### Implementation Specific Layer (ISL)

*If an implementation-specific layer is used, then a detailed description of how it performs its functions must be supplied, including any related source code or scripts. This description should allow an independent reconstruction of the implementation-specific layer.*

A command script was used to control and track the execution of queries. The scripts are contained in Appendix F. Qgen was used to generate the query streams, along with the appropriate substitution values.

### Profile-Directed Optimization

*If profile-directed optimization as described in Clause 5.2.9 is used, such use must be disclosed. In particular, the procedure and any scripts used to perform the optimization must be disclosed.*

Profile-directed optimization was not used.

# Clause 7: Pricing

## Hardware and Software Used in the Priced System

*A detailed list of hardware and software used in the priced system must be reported. Each item must have vendor part number, description, and release/revision level, and either general availability status or committed delivery date. If package-pricing is used, contents of the package must be disclosed. Pricing source(s) and effective date(s) of price(s) must also be reported.*

A detailed list of the hardware and software used in the priced system is included in the Executive Summary at the beginning of this document. The price quotes are located in Appendix G.

## Total Three Year Price

*The total 3-year price of the entire configuration must be reported including: hardware, software, and maintenance charges. Separate component pricing is recommended. The basis of all discounts used must be disclosed.*

A detailed price sheet of all the hardware and software used in this configuration, including the 3-year maintenance cost, and total price, is included in the executive summary at the beginning of this document. This purchase qualifies for a 16% discount from Dell Computer Corporation. The price quotes are located in Appendix G.

## Availability Date

*The committed delivery date for general availability of products used in the price calculations must be reported. When the priced system includes products with different availability dates, the availability date reported on the executive summary must be the date by which all components are committed to being available. The full disclosure report must report availability dates individually for at least each of the categories for which a pricing subtotal must be provided.*

All Dell components are available at the time of publication.

## Clause 8: Auditor-Related Items

### Auditor's Report

*The auditor's agency name, address, phone number, and Attestation letter with a brief audit summary report indicating compliance must be included in the full disclosure report. A statement should be included specifying who to contact in order to obtain further information regarding the audit process.*

Lorna Livingtree of Performance Metrics audited this implementation of the TPC Benchmark H. Information regarding the audit process may be obtained from:

Performance Metrics, Inc.  
137 Yankton St., Suite 101  
Folsom, CA 95630  
(Phone) (916) 985-1131  
(Fax) (916) 985-1185  
E-mail: [lorna@perfmetrics.com](mailto:lorna@perfmetrics.com)

Requests for this TPC Benchmark H Full Disclosure Report should be sent to:

Transaction Processing Performance Council  
c/o Shanley Public Relations  
777 North First Street, Suite 6000  
San Jose, CA 95112-6311 USA  
Telephone: (408) 295-8894  
Fax: (408) 295-9768



September 9, 2004

Mr. Nicholas Wakou  
Dell Computer Corporation  
One Dell Way  
Round Rock, TX 78682

I have verified the TPC Benchmark™ H for the following configuration:

Platform: DELL PowerEdge 6600  
Database Manager: Oracle Database 10g Enterprise Edition  
Operating System: Red Hat Enterprise Linux AS v2.4.21-14

CPU's	Memory	Total Disks	Qpph@ 300GB	QthH@300GB	QphH@300GB
8 Intel P4 Xeon MP @ 3 Ghz	32 GB	160 @ 18 GB 4 @ 36 GB for OS	<b>8,422.2</b>	<b>5,483.3</b>	<b>6,795.5</b>

In my opinion, these performance results were produced in compliance with the TPC requirements for the benchmark. The following attributes of the benchmark were given special attention:

- The database tables were defined with the proper columns, layout and sizes.
- The tested database was correctly scaled and populated for 300 GB using DBGEN. The version of DBGEN was 1.3.0.
- The qualification database layout was identical to the tested database except for the number and size of the files.
- The query text was verified to use only compliant variants and minor modifications.
- The executable query text was generated by QGEN and submitted through Oracle's standard interactive interface. The version of QGEN was 1.3.0.
- The validation of the query text against the qualification database produced compliant results.
- The refresh functions were properly implemented and executed the correct number of inserts and deletes.
- The load timing was properly measured and reported.
- The execution times were correctly measured and reported.
- The performance metrics were correctly computed and reported.
- The repeatability of the measurement was verified.

- The ACID properties were tested and verified.
- Sufficient mirrored log space was present on the tested system.
- The system pricing was checked for major components and maintenance.
- The executive summary pages of the FDR were verified for accuracy.

## **Auditor's Notes:**

Special attention was given to the query text of Query 15. This query used an approved variant (A) and a minor query modification allowed for select list expression aliases. This query was compliant with both requirements.

Sincerely,

A handwritten signature in cursive script that reads "Lorna Livingtree".

Lorna Livingtree  
Auditor

## ***Appendix A: Parameter settings***

## Appendix A

### init\_build.ora

```
aq_tm_processes          = 0
audit_trail              = false
compatible               = 10.0.0.0
control_files            = (+dgl/control_001,
+dgl/control_002)
cpu_count                = 4
db_block_checksum        = false
db_block_size            = 16384
db_cache_size            = 1200m
db_file_multiblock_read_count = 128
db_files                  = 500
db_name                  = 10i
db_writer_processes      = 4
dml_locks                = 5000
enqueue_resources        = 5000
global_names             = false
instance_name            = raca
shared_pool_size         = 512m
large_pool_size          = 300m
log_buffer               = 4194304
log_checkpoints_to_alert = true
max_dump_file_size       = unlimited
nls_date_format          = YYYY-MM-DD
open_cursors             = 600
optimizer_mode           = CHOOSE
optimizer_features_enable = 10.1.0.1
parallel_adaptive_multi_user = true
parallel_execution_message_size = 16384
parallel_max_servers     = 120
parallel_min_servers     = 100
pga_aggregate_target     = 10g
processes                = 1000
query_rewrite_enabled    = true
recovery_parallelism     = 8
replication_dependency_tracking = false
statistics_level         = basic
transactions             = 10
undo_management          = auto
undo_retention           = 400000
recovery_parallelism    = 1
disk_asynch_io          = TRUE
```

### init\_RACA.ora

```
instance_number         = 1
thread                  = 1
undo_management         = auto
undo_tablespace         = ts_undol
cluster_database        = true
cluster_interconnects   = 192.1.2.100
#cluster_interconnects = 192.1.2.105
ifile = /mnt/sdb2/home/oracle/10g/DB/dbs/init_build.ora
```

### init\_RACB.ora

```
instance_number         = 2
thread                  = 2
undo_management         = auto
undo_tablespace         = ts_undol
cluster_database        = true
cluster_interconnects   = 192.1.2.105
ifile = /mnt/sdb2/home/oracle/10g/DB/dbs/init_build.ora
```

### init+ASM1.ora

```
# Miscellaneous
#####
instance_type=asm

#####
# Pools
#####
#shared_pool_size=100M
shared_pool_size=120M
large_pool_size=12M

#####
# Security and Auditing
#####
remote_login_passwordfile=exclusive

#asm_diskgroups=DG1,DG2,DG3,DG4,DG5,DG6,DG7,DG8
,DG9,DG10,DG11,DG12,DG13,DG14,DG1
5,DG16
asm_diskgroups=DG1
+ASM2.instance_number=2
+ASM1.instance_number=1
instance_number=1
processes = 500
```

### init+ASM2.ora

```
#####
#####
# Copyright (c) 1991, 2001, 2002 by Oracle Corporation
#####
#####
# Cluster Database
#####
cluster_database=true
#####
# Diagnostics and Statistics
#####
background_dump_dest=/mnt/sdb2/home/oracle/10g/admin/+
ASM/bdump
core_dump_dest=/mnt/sdb2/home/oracle/10g/admin/+ASM/c
dump
```



## Appendix A

```
user_dump_dest=/mnt/sdb2/home/oracle/10g/admin/+ASM/u
dump
#####
# Miscellaneous
#####
instance_type=asm
#####
#
# Pools
#####
shared_pool_size=120M
large_pool_size=12M
#####
# Security and Auditing
#####
remote_login_passwordfile=exclusive
#asm_diskgroups=DG1,DG2,DG3,DG4,DG5,DG6,DG7,DG8
,DG9,DG10,DG11,DG12,DG13,DG14,DG1
5,DG16
asm_diskgroups='DG1'
+ASM2.instance_number=2
+ASM1.instance_number=1
instance_number=2

.bashrc
# .bashrc

# User specific aliases and functions

# Source global definitions
if [ -f /etc/bashrc ]; then
    . /etc/bashrc
fi

export ORACLE_SID=`uname -n | sed "s/PE6600/RAC/"`
#export ORACLE_SID=1g_1
export ASM_SID=+ASM1
export ORACLE_BASE=/mnt/sdb2/home/oracle/10g
export ORACLE_HOME=$ORACLE_BASE/DB
export O=$ORACLE_HOME
export ORA_CRS_HOME=/mnt/sdb2/home/oracle/CRS

export FRAME_PATH=$HOME/frame
export KIT_DIR=$HOME/kit
export
PATH=.:$PATH:$HOME/bin:$O:$O/bin:$O/rdbms/log:$FR
AME_PATH/bin
export
LD_LIBRARY_PATH=/usr/lib:$ORACLE_HOME/lib:$OR
ACLE_HOME/rdbms/lib

export PATH=$PATH:/mnt/sdb2/home/oracle/kit/utlis
alias asmlog="tail -f
$ORACLE_HOME/rdbms/log/alert_${ASM_SID}.log "
alias cdb="cd $ORACLE_HOME/dbs"
alias cdbin="cd $ORACLE_HOME/bin"

alias cdbuild="cd
/mnt/sdb2/home/oracle/kit/schema/10.0/build"
alias cdf="cd $FRAME_PATH"
alias cdframe="cd $FRAME_PATH"
alias cdfbin="cd $FRAME_PATH/bin"
alias cdlog="cd $ORACLE_HOME/rdbms/log"
alias cdkit="cd $KIT_DIR"
alias cdwork="cd $KIT_DIR/saraj"
alias cdfr="cd $FRAME_PATH"
alias cdstats="cd $FRAME_PATH/stats"
```

## ***Appendix B: Database Build Scripts***

## Appendix B

```
alter database add logfile thread 2 '+dg1/log_3' size 4096m
reuse,
                                     '+dg1/log_4' size
4096m reuse;
alter database enable public thread 2;
```

### build\_dg\_AUDIT2.sh

```
export ORACLE_SID=+ASM1
sqlplus /NOLOG <<!
connect /as sysdba
drop diskgroup dg1 including contents;
CREATE DISKGROUP DG1 External REDUNDANCY
DISK
'/dev/raw/raw1' SIZE 61891M ,
'/dev/raw/raw2' SIZE 61891M ,
'/dev/raw/raw3' SIZE 61891M ,
'/dev/raw/raw4' SIZE 61891M ,
'/dev/raw/raw5' SIZE 61891M ,
'/dev/raw/raw6' SIZE 61891M ,
'/dev/raw/raw7' SIZE 61891M ,
'/dev/raw/raw8' SIZE 61891M ,
'/dev/raw/raw9' SIZE 61891M ,
'/dev/raw/raw10' SIZE 61891M ,
'/dev/raw/raw11' SIZE 61891M ,
'/dev/raw/raw12' SIZE 61891M ,
'/dev/raw/raw13' SIZE 61891M ,
'/dev/raw/raw14' SIZE 61891M ,
'/dev/raw/raw15' SIZE 61891M ,
'/dev/raw/raw16' SIZE 61891M;
!
```

### dbcre\_AUDIT2.sh

```
#!/bin/ksh
echo "database creation"
date;

sqlplus /NOLOG <<!
connect /as sysdba

startup pfile =
/mnt/sdb2/home/oracle/10g/DB/dbs/init_build.ora nomount;
create database
controlfile reuse
logfile '+dg1/log_1' size 4096m reuse,
        '+dg1/log_2' size 4096m reuse
datafile '+dg1/sys_1' size 1024m reuse
sysaux datafile '+dg1/sysaux_1' size 1024m reuse
undo tablespace ts_undol
    datafile '+dg1/undo_1' size 8192m reuse
default temporary tablespace ts_temp
    tempfile '+dg1/temp_1' size 14400m reuse
    extent management local uniform size 10m
maxdatafiles 4000
maxinstances 2;

create undo tablespace ts_undol datafile '+dg1/undo_2' size
8192m reuse;
```

```
set termout off
set echooff
spool /tmp/cat
@?/rdbms/admin/catalog.sql;
@?/rdbms/admin/catparr.sql;
@?/rdbms/admin/catproc.sql;
connect system/manager
@?/rdbms/admin/utlxplan.sql;
@?/rdbms/admin/pupbld.sql;
spool off
!
echo "end of database creation"
date
```

### dapop\_AUDIT2.sh

```
#!/bin/bash
sqlplus /NOLOG <<EOF
connect / as sysdba
drop user tpch cascade;
grant DBA
to tpch identified by tpch;
connect tpch/tpch;
drop directory ff1;
drop directory ff2;
drop directory ff3;
drop directory ff4;
drop directory ff5;
drop directory ff6;
drop directory ff7;
drop directory ff8;
drop directory ff9;
drop directory ff10;
drop directory ff11;
drop directory ff12;
drop directory ff13;
drop directory ff14;
drop directory ff15;
drop directory ff16;
create directory ff1 as '/ff1';
create directory ff2 as '/ff2';
create directory ff3 as '/ff3';
create directory ff4 as '/ff4';
create directory ff5 as '/ff5';
create directory ff6 as '/ff6';
create directory ff7 as '/ff7';
create directory ff8 as '/ff8';
create directory ff9 as '/ff9';
create directory ff10 as '/ff10';
create directory ff11 as '/ff11';
create directory ff12 as '/ff12';
create directory ff13 as '/ff13';
```

## Appendix B

```
create directory ff14 as '/ff14';
create directory ff15 as '/ff15';
create directory ff16 as '/ff16';
```

```
drop table l_et;
create table l_et(
  l_orderkey      number ,
  l_partkey       number ,
  l_suppkey       number ,
  l_linenumbr     number ,
  l_quantity      number ,
  l_extendedprice number ,
  l_discount      number ,
  l_tax           number ,
  l_returnflag    char(1) ,
  l_linestatus    char(1) ,
  l_shipdate      date ,
  l_commitdate    date ,
  l_receiptdate   date ,
  l_shipinstruct  char(25) ,
  l_shipmode      char(10) ,
  l_comment       varchar(44)
)
```

```
organization external (
type ORACLE_LOADER
default directory ff1
access parameters
(
  records delimited by newline
  nobadfile
  nologfile
  fields terminated by '|'
  missing field values are null
)
```

```
location (
ff1:'lineitem.tbl.1',
ff2:'lineitem.tbl.2',
ff3:'lineitem.tbl.3',
ff4:'lineitem.tbl.4',
ff5:'lineitem.tbl.5',
ff6:'lineitem.tbl.6',
ff7:'lineitem.tbl.7',
ff8:'lineitem.tbl.8',
ff9:'lineitem.tbl.9',
ff10:'lineitem.tbl.10',
ff11:'lineitem.tbl.11',
ff12:'lineitem.tbl.12',
ff13:'lineitem.tbl.13',
ff14:'lineitem.tbl.14',
ff15:'lineitem.tbl.15',
ff16:'lineitem.tbl.16'
))
```

```
reject limit unlimited;
```

```
drop table o_et;
create table o_et(
  o_orderkey      number ,
  o_custkey       number ,
  o_orderstatus   char(1) ,
```

```
o_totalprice     number ,
o_orderdate      date ,
o_orderpriority  char(15) ,
o_clerk          char(15) ,
o_shippriority   number ,
o_comment        varchar(79)
)
```

```
organization external (
type ORACLE_LOADER
default directory ff1
access parameters
(
  records delimited by newline
  nobadfile
  nologfile
  fields terminated by '|'
  missing field values are null
)
```

```
location (
ff1:'orders.tbl.1',
ff2:'orders.tbl.2',
ff3:'orders.tbl.3',
ff4:'orders.tbl.4',
ff5:'orders.tbl.5',
ff6:'orders.tbl.6',
ff7:'orders.tbl.7',
ff8:'orders.tbl.8',
ff9:'orders.tbl.9',
ff10:'orders.tbl.10',
ff11:'orders.tbl.11',
ff12:'orders.tbl.12',
ff13:'orders.tbl.13',
ff14:'orders.tbl.14',
ff15:'orders.tbl.15',
ff16:'orders.tbl.16'
))
```

```
reject limit unlimited;
```

```
drop table ps_et;
create table ps_et(
  ps_partkey      number ,
  ps_suppkey      number ,
  ps_availqty     number ,
  ps_supplycost   number ,
  ps_comment      varchar(199)
)
```

```
organization external (
type ORACLE_LOADER
default directory ff1
access parameters
(
  records delimited by newline
  nobadfile
  nologfile
  fields terminated by '|'
  missing field values are null
)
```

```
location (
ff3:'partsupp.tbl.1',
```

## Appendix B

```
ff2:'partsupp.tbl.2',
ff3:'partsupp.tbl.3',
ff4:'partsupp.tbl.4',
ff5:'partsupp.tbl.5',
ff6:'partsupp.tbl.6',
ff7:'partsupp.tbl.7',
ff8:'partsupp.tbl.8',
ff9:'partsupp.tbl.9',
ff10:'partsupp.tbl.10',
ff11:'partsupp.tbl.11',
ff12:'partsupp.tbl.12',
ff13:'partsupp.tbl.13',
ff14:'partsupp.tbl.14',
ff15:'partsupp.tbl.15',
ff16:'partsupp.tbl.16'
))
reject limit unlimited;
```

```
drop table p_et;
create table p_et(
  p_partkey      number ,
  p_name         varchar(55) ,
  p_mfgr         char(25) ,
  p_brand        char(10) ,
  p_type         varchar(25) ,
  p_size         number ,
  p_container    char(10) ,
  p_retailprice  number ,
  p_comment      varchar(23)
)
organization external (
type ORACLE_LOADER
default directory ff1
access parameters
(
  records delimited by newline
  nobadfile
  nologfile
  fields terminated by '|'
  missing field values are null
)
  location (
ff1:'part.tbl.1',
ff2:'part.tbl.2',
ff3:'part.tbl.3',
ff4:'part.tbl.4',
ff5:'part.tbl.5',
ff6:'part.tbl.6',
ff7:'part.tbl.7',
ff8:'part.tbl.8',
ff9:'part.tbl.9',
ff10:'part.tbl.10',
ff11:'part.tbl.11',
ff12:'part.tbl.12',
ff13:'part.tbl.13',
ff14:'part.tbl.14',
ff15:'part.tbl.15',
ff16:'part.tbl.16'
))
```

```
reject limit unlimited;

drop table c_et;
create table c_et(
  c_custkey      number ,
  c_name         varchar(25) ,
  c_address      varchar(40) ,
  c_nationkey    number ,
  c_phone        char(15) ,
  c_acctbal      number ,
  c_mktsegment   char(10) ,
  c_comment      varchar(117)
)
organization external (
type ORACLE_LOADER
default directory ff1
access parameters
(
  records delimited by newline
  nobadfile
  nologfile
  fields terminated by '|'
  missing field values are null
)
  location (
ff1:'customer.tbl.1',
ff2:'customer.tbl.2',
ff3:'customer.tbl.3',
ff4:'customer.tbl.4',
ff5:'customer.tbl.5',
ff6:'customer.tbl.6',
ff7:'customer.tbl.7',
ff8:'customer.tbl.8',
ff9:'customer.tbl.9',
ff10:'customer.tbl.10',
ff11:'customer.tbl.11',
ff12:'customer.tbl.12',
ff13:'customer.tbl.13',
ff14:'customer.tbl.14',
ff15:'customer.tbl.15',
ff16:'customer.tbl.16'
))
reject limit unlimited;
```

```
drop table s_et;
create table s_et(
  s_suppkey      number ,
  s_name         char(25) ,
  s_address      varchar(40) ,
  s_nationkey    number ,
  s_phone        char(15) ,
  s_acctbal      number ,
  s_comment      varchar(101)
)
organization external (
type ORACLE_LOADER
default directory ff1
access parameters
(
```

## Appendix B

```
records delimited by newline
nbadfile
nologfile
fields terminated by '|'
missing field values are null
)
location (
ff1:'supplier.tbl.1',
ff2:'supplier.tbl.2',
ff3:'supplier.tbl.3',
ff4:'supplier.tbl.4',
ff5:'supplier.tbl.5',
ff6:'supplier.tbl.6',
ff7:'supplier.tbl.7',
ff8:'supplier.tbl.8',
ff9:'supplier.tbl.9',
ff10:'supplier.tbl.10',
ff11:'supplier.tbl.11',
ff12:'supplier.tbl.12',
ff13:'supplier.tbl.13',
ff14:'supplier.tbl.14',
ff15:'supplier.tbl.15',
ff16:'supplier.tbl.16'
))
reject limit unlimited;

drop table n_et;
create table n_et(
  n_nationkey    number ,
  n_name         char(25) ,
  n_regionkey   number ,
  n_comment     varchar(152)
)
organization external (
type ORACLE_LOADER
default directory ff1
access parameters
(
      records delimited by newline
      nobadfile
      nologfile
      fields terminated by '|'
      missing field values are null
)
location (
ff16:'nation.tbl'
))
reject limit unlimited;

drop table r_et;
create table r_et(
  r_regionkey    number ,
  r_name         char(25) ,
  r_comment     varchar(152)
)
organization external (
type ORACLE_LOADER
default directory ff1
access parameters
```

```
(
      records delimited by newline
      nobadfile
      nologfile
      fields terminated by '|'
      missing field values are null
)
location (
ff16:'region.tbl'
))
reject limit unlimited;

alter table l_et parallel;
alter table o_et parallel;
alter table ps_et parallel;
alter table p_et parallel;
alter table c_et parallel;
alter table s_et parallel;

alter user tpch default tablespace ts_default;
alter user tpch temporary tablespace ts_temp;

@?/rdbms/admin/utlxplan.sql;

set timing on
set echo on
!date

rem drop table lineitem;
create table lineitem(
  l_shipdate      ,
  l_orderkey      NOT NULL,
  l_discount      NOT NULL,
  l_extendedprice NOT NULL,
  l_suppkey       NOT NULL,
  l_quantity      NOT NULL,
  l_returnflag    ,
  l_partkey       NOT NULL,
  l_linestatus    ,
  l_tax           NOT NULL,
  l_commitdate    ,
  l_receiptdate   ,
  l_shipmode      ,
  l_linenumber    NOT NULL,
  l_shipinstruct  ,
  l_comment
)
pctfree 1
pctused 99
intrans 10
tablespace ts_data
storage (initial 132m freelist groups 2 freelists 99)
compress
parallel
nologging
partition by range (l_shipdate)
subpartition by hash(l_partkey)
subpartitions 16
(
```



## Appendix B

```
partition item59 values less than (to_date('1996-11-01','YYYY-MM-DD')) ,
partition item60 values less than (to_date('1996-12-01','YYYY-MM-DD')) ,
partition item61 values less than (to_date('1997-01-01','YYYY-MM-DD')) ,
partition item62 values less than (to_date('1997-02-01','YYYY-MM-DD')) ,
partition item63 values less than (to_date('1997-03-01','YYYY-MM-DD')) ,
partition item64 values less than (to_date('1997-04-01','YYYY-MM-DD')) ,
partition item65 values less than (to_date('1997-05-01','YYYY-MM-DD')) ,
partition item66 values less than (to_date('1997-06-01','YYYY-MM-DD')) ,
partition item67 values less than (to_date('1997-07-01','YYYY-MM-DD')) ,
partition item68 values less than (to_date('1997-08-01','YYYY-MM-DD')) ,
partition item69 values less than (to_date('1997-09-01','YYYY-MM-DD')) ,
partition item70 values less than (to_date('1997-10-01','YYYY-MM-DD')) ,
partition item71 values less than (to_date('1997-11-01','YYYY-MM-DD')) ,
partition item72 values less than (to_date('1997-12-01','YYYY-MM-DD')) ,
partition item73 values less than (to_date('1998-01-01','YYYY-MM-DD')) ,
partition item74 values less than (to_date('1998-02-01','YYYY-MM-DD')) ,
partition item75 values less than (to_date('1998-03-01','YYYY-MM-DD')) ,
partition item76 values less than (to_date('1998-04-01','YYYY-MM-DD')) ,
partition item77 values less than (to_date('1998-05-01','YYYY-MM-DD')) ,
partition item78 values less than (to_date('1998-06-01','YYYY-MM-DD')) ,
partition item79 values less than (to_date('1998-07-01','YYYY-MM-DD')) ,
partition item80 values less than (to_date('1998-08-01','YYYY-MM-DD')) ,
partition item81 values less than (to_date('1998-09-01','YYYY-MM-DD')) ,
partition item82 values less than (to_date('1998-10-01','YYYY-MM-DD')) ,
partition item83 values less than (to_date('1998-11-01','YYYY-MM-DD')) ,
partition item84 values less than (MAXVALUE))
as select
  l_shipdate      ,
  l_orderkey      ,
  l_discount      ,
  l_extendedprice ,
  l_suppkey       ,
  l_quantity      ,
  l_returnflag    ,
```

```
  l_partkey       ,
  l_linestatus    ,
  l_tax           ,
  l_commitdate    ,
  l_receiptdate   ,
  l_shipmode      ,
  l_linenumbers   ,
  l_shipinstruct  ,
  l_comment
from l_et;
!date

rem drop table orders;
create table orders(
  o_orderdate      ,
  o_orderkey       NOT NULL,
  o_custkey        NOT NULL,
  o_orderpriority  ,
  o_shippriority   ,
  o_clerk          ,
  o_orderstatus    ,
  o_totalprice     ,
  o_comment
)
pctfree 1
pctused 99
initrans 10
tablespace ts_data
storage (initial 44m freelist groups 2 freelists 99)
compress
parallel
nologging
partition by range (o_orderdate)
subpartition by hash(o_custkey)
subpartitions 16
(
  partition ord1 values less than (to_date('1992-01-01','YYYY-MM-DD')),
  partition ord2 values less than (to_date('1992-02-01','YYYY-MM-DD')),
  partition ord3 values less than (to_date('1992-03-01','YYYY-MM-DD')),
  partition ord4 values less than (to_date('1992-04-01','YYYY-MM-DD')),
  partition ord5 values less than (to_date('1992-05-01','YYYY-MM-DD')),
  partition ord6 values less than (to_date('1992-06-01','YYYY-MM-DD')),
  partition ord7 values less than (to_date('1992-07-01','YYYY-MM-DD')),
  partition ord8 values less than (to_date('1992-08-01','YYYY-MM-DD')),
  partition ord9 values less than (to_date('1992-09-01','YYYY-MM-DD')),
  partition ord10 values less than (to_date('1992-10-01','YYYY-MM-DD')),
  partition ord11 values less than (to_date('1992-11-01','YYYY-MM-DD')),
```





## Appendix B

```
partition ord70 values less than (to_date('1997-10-01','YYYY-
MM-DD')),
partition ord71 values less than (to_date('1997-11-01','YYYY-
MM-DD')),
partition ord72 values less than (to_date('1997-12-01','YYYY-
MM-DD')),
partition ord73 values less than (to_date('1998-01-01','YYYY-
MM-DD')),
partition ord74 values less than (to_date('1998-02-01','YYYY-
MM-DD')),
partition ord75 values less than (to_date('1998-03-01','YYYY-
MM-DD')),
partition ord76 values less than (to_date('1998-04-01','YYYY-
MM-DD')),
partition ord77 values less than (to_date('1998-05-01','YYYY-
MM-DD')),
partition ord78 values less than (to_date('1998-06-01','YYYY-
MM-DD')),
partition ord79 values less than (to_date('1998-07-01','YYYY-
MM-DD')),
partition ord80 values less than (to_date('1998-08-01','YYYY-
MM-DD')),
partition ord81 values less than (to_date('1998-09-01','YYYY-
MM-DD')),
partition ord82 values less than (to_date('1998-10-01','YYYY-
MM-DD')),
partition ord83 values less than (to_date('1998-11-01','YYYY-
MM-DD')),
partition ord84 values less than (MAXVALUE))
as select
  o_orderdate      ,
  o_orderkey       ,
  o_custkey        ,
  o_orderpriority  ,
  o_shippriority   ,
  o_clerk          ,
  o_orderstatus    ,
  o_totalprice     ,
  o_comment
from o_et;
!date
```

```
rem drop table partsupp;
create table partsupp(
  ps_partkey      NOT NULL,
  ps_suppkey      NOT NULL,
  ps_supplycost   NOT NULL,
  ps_availqty     ,
  ps_comment      ,
constraint pk_partkey_suppkey_1 primary key(ps_partkey,
ps_suppkey)
)
organization index
partition by hash(ps_partkey)
partitions 16
storage (initial 256m freelist groups 2 freelists 99)
parallel
nologging
pctthreshold 50
```

```
tablespace ts_data
as select
  ps_partkey      ,
  ps_suppkey      ,
  ps_supplycost   ,
  ps_availqty     ,
  ps_comment
from ps_et;
!date

rem drop table customer;
create table customer(
  c_custkey       NOT NULL,
  c_mktsegment    ,
  c_nationkey     ,
  c_name          ,
  c_address       ,
  c_phone         ,
  c_acctbal      ,
  c_comment
)
pctfree 0
pctused 99
storage (initial 800m freelist groups 2 freelists 99)
compress
parallel
nologging
partition by hash (c_custkey)
partitions 16
tablespace ts_data
as select
  c_custkey      ,
  c_mktsegment   ,
  c_nationkey    ,
  c_name         ,
  c_address      ,
  c_phone        ,
  c_acctbal     ,
  c_comment
from c_et;
!date
```

```
rem drop table part;
create table part(
  p_partkey      NOT NULL,
  p_type         ,
  p_size         ,
  p_brand        ,
  p_name         ,
  p_container    ,
  p_mfgr         ,
  p_retailprice  ,
  p_comment
)
pctfree 0
pctused 99
storage (initial 800m freelist groups 2 freelists 99)
compress
parallel
```

## Appendix B

```
nologging
partition by hash (p_partkey)
partitions 16
tablespace ts_data
as select
  p_partkey      ,
  p_type         ,
  p_size        ,
  p_brand       ,
  p_name        ,
  p_container   ,
  p_mfgr        ,
  p_retailprice ,
  p_comment
from p_et;
!date

rem drop table supplier;
create table supplier(
  s_suppkey      NOT NULL,
  s_nationkey    ,
  s_comment      ,
  s_name         ,
  s_address      ,
  s_phone        ,
  s_acctbal
)
pctfree 0
pctused 99
storage (initial 100m freelist groups 2 freelists 99)
compress
parallel
nologging
partition by hash (s_suppkey)
partitions 16
tablespace ts_data
as select
  s_suppkey      ,
  s_nationkey    ,
  s_comment      ,
  s_name         ,
  s_address      ,
  s_phone        ,
  s_acctbal
from s_et;

rem drop table nation;
create table nation(
  n_nationkey    NOT NULL,
  n_name         ,
  n_regionkey    ,
  n_comment      )
as select * from n_et;

rem drop table region;
create table region(
  r_regionkey    ,
  r_name         ,
  r_comment      )
as select * from r_et;

!date
drop table l_et;
drop table o_et;
drop table ps_et;
drop table p_et;
drop table c_et;
drop table s_et;
drop table n_et;
drop table r_et;

!date

rem drop index i_l_orderkey;
create index i_l_orderkey
on lineitem (l_orderkey) global partition by hash (l_orderkey)
partitions 16
pctfree 2
initrans 10
tablespace ts_data
storage (initial 132m freelist groups 2 freelists 99)
parallel
compute statistics
nologging;
alter index i_l_orderkey allocate extent (size 132m);
alter index i_l_orderkey allocate extent (size 132m);
alter index i_l_orderkey allocate extent (size 132m);
alter index i_l_orderkey allocate extent (size 132m);

!date

rem drop index i_o_orderkey;
create unique index i_o_orderkey
on orders (o_orderkey) global partition by hash (o_orderkey)
partitions 16
pctfree 2
initrans 10
tablespace ts_data
storage (initial 44m freelist groups 2 freelists 99 )
parallel
compute statistics
nologging;

addts.sh

sqlplus /NOLOG<<!
connect / as sysdba;
alter tablespace $1 add datafile '$2' size $3 reuse;
!

addtts.sh

sqlplus /NOLOG<<!
connect / as sysdba;
alter tablespace $1 add tempfile '$2' size $3 reuse;
!

tscre_AUDIT2.sh
#!/bin/ksh
```

## Appendix B

```
echo "START: tablespace creation"
date;

sqlplus /NOLOG <<!
connect /as sysdba

create tablespace ts_default
datafile '+dg1/default_1' size 2048m reuse
extent management local autoallocate;

create tablespace ts_data
nologging
datafile '+dg1/data_1' size 30720m reuse
extent management local autoallocate;

!

i=1
while [ $i -lt 16 ]
do
    i=`expr $i + 1`
    addts.sh ts_data +dg1/data_1 $i 30720m &
done

wait;

i=1
while [ $i -lt 10 ]
do
    i=`expr $i + 1`
    addts.sh ts_temp +dg1/temp_1 $i 14400m &
done

wait;

echo "END: tablespace creation"
date;
```

## ***Appendix C: ACID Scripts***

## Appendix C

### a\_query.sql

```
Rem
Rem $Header: a_query.sql 06-aug-99.10:51:10 mpoess Exp $
Rem
Rem a_query.sql
Rem
Rem Copyright (c) Oracle Corporation 1999. All Rights
Reserved.
Rem
Rem NAME
Rem a_query.sql - <one-line expansion of the name>
Rem
rem DESCRIPTION
Rem Performs ACID Query for TPC-D benchmark.
Rem Asks user to input values for o_key
Rem The range of okey is 1 to 600000
Rem
```

```
=====
=====
Rem
Rem Usage: sqlplus tpcd/tpcd @a_query <o_key>
Rem
Rem
Rem MODIFIED (MM/DD/YY)
Rem mpoess 08/06/99 - Creation
Rem mpoess 08/06/99 - Created
Rem
```

```
set serverout on;
```

```
select
'BEFORE ACID QUERY' as STAGE,
substr(TO_CHAR(sysdate,'YYYY-MM-DD
HH:MI:SS'),1,20) as CURRENT_TIME
from dual;
```

```
select SUM(trunc(trunc(1_extendedprice * (1-1_discount),2) *
(1+1_tax),2)) AS RESULT
from lineitem
where l_orderkey = &&1;
```

```
select
'AFTER ACID QUERY' as STAGE,
substr(TO_CHAR(sysdate,'YYYY-MM-DD
HH:MI:SS'),1,20) as CURRENT_TIME
from dual;
```

```
exit;
```

### a\_query2.sql

```
Rem
Rem $Header: aquery2.sql 07-aug-99.23:54:47 mpoess Exp $
Rem
Rem aquery2.sql
Rem
```

```
Rem Copyright (c) Oracle Corporation 1999. All Rights
Reserved.
```

```
Rem
Rem NAME
Rem aquery2.sql - <one-line expansion of the name>
Rem
Rem DESCRIPTION
Rem Performs query on PARTSUPP for TPC-D
benchmark
Rem Isolation Test 5.
Rem Asks user to input values for ps_partkey and
ps_suppkey
Rem The range for ps_partkey is 1 to 20000
Rem The range for ps_suppkey is 1 to 1000
Rem A valid combination is 46 and 47
Rem Usage: sqlplus tpcd/tpcd @a_query2 <ps_partkey>
<ps_suppkey>
```

```
Rem
Rem MODIFIED (MM/DD/YY)
Rem mpoess 08/07/99 - Creation
Rem mpoess 08/07/99 - Created
Rem
```

```
rem DESCRIPTION
rem Performs query on PARTSUPP for TPC-D
benchmark
rem Isolation Test 5.
rem Asks user to input values for ps_partkey and
ps_suppkey
rem The range for ps_partkey is 1 to 20000
rem The range for ps_suppkey is 1 to 1000
rem A valid combination is 46 and 47
```

```
set serverout on;
```

```
select
'BEFORE PARTSUPP QUERY' as STAGE,
substr(TO_CHAR(sysdate,'YYYY-MM-DD
HH:MI:SS'),1,20) as CURRENT_TIME
from dual;
```

```
select *
from partsupp
where ps_partkey = &&1
and ps_suppkey = &&2;
```

```
select
'AFTER PARTSUPP QUERY' as STAGE,
substr(TO_CHAR(sysdate,'YYYY-MM-DD
HH:MI:SS'),1,20) as CURRENT_TIME
from dual;
```

```
exit;
```

### atom.sh

```
#!/bin/ksh
#
# $Header: atom.sh 08-aug-99.13:48:02 mpoess Exp $
#
# atom.sh
```

## Appendix C

```
#
# Copyright (c) Oracle Corporation 1999. All Rights
Reserved.
#
# NAME
# atom.sh - <one-line expansion of the name>
#
# DESCRIPTION
# Performs atomicity tests.
# Usage: atom.sh [-n iter] [-p prog] [-u usr/pswd] -h
#
# Options: See usage below
#
# NOTES
# <other useful comments, qualifications, etc.>
#
# MODIFIED (MM/DD/YY)
# mpoess 08/08/99 - Creation
# mpoess 08/08/99 - Creation
#

.$KIT_DIR/env

OH=$ORACLE_HOME
# ACID_DIR=$TPCD_KIT_DIR/audit set in env
OUT_DIR=$ACID_OUT
DURA_DIR=$ACID_DIR/dura

usage() {
    echo ""
    echo "Usage: $0 [-n iter] [-p prog] [-u usr/pswd] -h"
    echo ""
    echo "-n iter : number of iterations, default is 100"
    echo "-p prog : program to run, default is atranspl.otf"
    echo "-u usr/pswd : user/password combo for database
access, default is tpcd/tpcd"
    echo "-h : print this usage summary"
    exit 1;
}

ITER=3
SF=1
PROG=$KIT_DIR/utills/atranspl
OUT=${OUT_DIR}/atom
USER=${DATABASE_USER}

set -- `getopt "n:p:u:h" "$@"` || usage

while :
do
    case "$1" in
    -n) shift; ITER=$1;;
    -p) shift; PROG=$1;;
    -u) shift; USER=$1;;
    -h) usage; exit 0;;
    --) break;;
    esac
    shift
done
```

```
done

echo "Starting Atomicity Test at `date`..."
echo ""
echo "Performing $ITER ACID transactions with COMMIT"
echo ""

$KIT_DIR/utills/randkey $ITER $SF u$USER | $PROG 1 1 1
0 u$USER > ${OUT}c 2>&1

echo "ACID transactions with COMMIT ended. Output in
${OUT}c"
echo ""
echo "Performing $ITER ACID transactions with
ROLLBACK"
echo ""

$KIT_DIR/utills/randkey $ITER $SF u$USER | $PROG 1 1 0
0 u$USER > ${OUT}r 2>&1

echo "ACID transactions with ROLLBACK ended. Output in
${OUT}r"
echo ""
echo "Ending Atomicity Test at `date`..."
```

### atranspl.c

```
/* Copyright (c) 2001, 2002, Oracle Corporation. All rights
reserved. */

/*
NAME
    atranspl.c - <one-line expansion of the name>

DESCRIPTION
    TPC-HR benchmark ACID transaction driver, OCI version
8

NOTES
    <other useful comments, qualifications, etc.>

MODIFIED (MM/DD/YY)
mpoess 10/23/02 - mpoess_update_from_visa
mpoess 10/17/01 - add parameter in ACIDinit
mpoess 02/22/01 - enlarge timing array
mpoess 01/04/01 - Creation

*/

#include <stdio.h>
#include <stdlib.h>
#include <sys/types.h>
#include <sys/stat.h>
#include <fcntl.h>

#include "atranspl.h"

/* Declare error handling functions */
```

## Appendix C

```

double gettime();
void sql_error();
void usage();
void ACIDinit();
void ACIDexit();
int atoi();
void srand48();
long lrand48();

/* declarations for ORDERS */

int o_key = 0;
double o_tprice = 0.0;
double o_newtprice = 0.0;

/* declarations for LINEITEM */

int l_key = 0;
int l_pkey = 0;
int l_skey = 0;

int l_quan = 0;
int l_newquan = 0;
double l_eprice = 0.0;
double l_neweprice = 0.0;
double l_disc = 0.0;
double l_tax = 0.0;

sb2 l_npricei;

/* other declarations */

int delta = 0;
double rprice;
double cost;

int proc_no = 1; /* process number, global */
int num_streams = 1; /* number of transaction streams */
/*
int trig = 0; /* Trigger Time */
int slp = 0; /* Sleep Time */

int logfile; /* fdes for logfile for durability (optional) */
/*
int outfile = 1; /* output file (optional) */
#ifdef LINUX
FILE *infile; /* input file (optional) */
#else
FILE *infile = stdin; /* input file (optional) */
/* in the format of <o_key> <delta> */
#endif
char lname[UNAME_LEN]; /* username/passwd combo */
/*
char *passwd; /* pointer to password */
/*

char buf[WRITE_BUF_LEN]; /* buffer to write */
/*

```

```

unsigned flag = (unsigned) 0; /* flag to store all sorts of
options */

#define INFILE 0x01u
#define OUTFILE 0x02u
#define LOGFILE 0x04u
#define COMMIT 0x08u
#define DELTA 0x10u

double tr_end = 0.0; /* transaction end time */
double tr_start = 0.0; /* transaction start time */

int num_iter = 0; /* number of iterations */

time_t curr_time; /* Current Time */

/* OCI handles */

OCIEnv *tpcenv = NULL;
OCIServer *tpcsrv = NULL;
OCIError *errhp = NULL;
OCISvcCtx *tpcsvc = NULL;
OCISession *tpcusr = NULL;
OCIStmt *curi = NULL;
OCIStmt *curr = NULL;
OCIStmt *cure1 = NULL;
OCIStmt *cure2 = NULL;

/* OCI bind handles */

#ifdef NOLKEY
OCIBind *l_keyi_bp = NULL;
OCIBind *o_keyi_bp = NULL;
#endif /* NOLKEY */

OCIBind *l_key_bp = NULL;
OCIBind *o_key_bp = NULL;
OCIBind *delta_bp = NULL;
OCIBind *l_pkey_bp = NULL;
OCIBind *l_skey_bp = NULL;
OCIBind *l_quan_bp = NULL;
OCIBind *l_newquan_bp = NULL;
OCIBind *l_tax_bp = NULL;
OCIBind *l_disc_bp = NULL;
OCIBind *l_eprice_bp = NULL;
OCIBind *l_neweprice_bp = NULL;
OCIBind *o_tprice_bp = NULL;
OCIBind *o_newtprice_bp = NULL;
OCIBind *rprice_bp = NULL;
OCIBind *cost_bp = NULL;

OCIBind *l_neweprice1_bp = NULL;
OCIBind *l_newquan1_bp = NULL;
OCIBind *o_key1_bp = NULL;
OCIBind *l_key1_bp = NULL;

OCIBind *o_newtprice2_bp = NULL;
OCIBind *o_key2_bp = NULL;

```



## Appendix C

```

sword status = OCI_SUCCESS; /* OCI return value */
char sqlstmt[1024];

/* usage: prints the usage of the program */

void usage()
{
    fprintf(stderr, "\nUsage: atrans.o[st]t <proc_no>
<num_streams> <commit> <delta>[i<pathname for input>]
[o<pathname for output>] [d<pathname for durability file>]
[u<uid/passwd>] \n\n");

    fprintf(stderr, "  proc_no      :the process number within this
ACID\n");
    fprintf(stderr, "  num_streams  :the total number of ACID
transaction streams\n");
    fprintf(stderr, "  commit      :1 to commit transaction, abort
otherwise\n");
    fprintf(stderr, "  delta       :1 to generate new random delta,
otherwise obtain delta from input\n");
    fprintf(stderr, "  OPTIONAL PARAMETERS:\n");
    fprintf(stderr, "  i<pathname for input>   :full path name
for input file - default is stdin\n");
    fprintf(stderr, "  o<pathname for output>  :full path name
for output file - default is stdout\n");
    fprintf(stderr, "  d<pathname for durability> :full path name
for durability success file - must specify for durability test\n");
    fprintf(stderr, "  u<uid/passwd>
:Username/Password string - default is tcpd/tcpd\n");
    fprintf(stderr, "  t<trigger>       :Trigger Time - sleep
<trigger> seconds before start\n");
    fprintf(stderr, "  s<sleep>       :Sleep Time - sleep
<sleep> seconds before commit or rollback\n");
    exit(-1);
}

void ACIDexit() {
    OCILogoff(tpcsvc, errhp);
    OCIhfree(tpcenv, OCI_HTYPE_STMT);
    OCIhfree(tpcsvc, OCI_HTYPE_SVCCTX);
    OCIhfree(tpcsrv, OCI_HTYPE_SERVER);
    OCIhfree(tpcusr, OCI_HTYPE_SESSION);
}

/* type: 0 if environment handle is passed, 1 if error handle is
passwd */

void sql_error(errhp, status, type)
    OCIError *errhp;
    sword status;
    sword type;

```

```

{
    char msg[2048];
    ub4 errcode;
    ub4 msglen;
    int i, j;

    switch(status) {
    case OCI_SUCCESS_WITH_INFO:
        fprintf(stderr, "Error: Statement returned with info.\n");
        if (type)
            (void) OCIErrorGet(errhp, 1, NULL, (sb4 *) &errcode,
(text*) msg,
                2048, OCI_HTYPE_ERROR);
        else
            (void) OCIErrorGet(errhp, 1, NULL, (sb4 *) &errcode,
(text*) msg,
                2048, OCI_HTYPE_ENV);
        fprintf(stderr, "%s\n", msg);
        break;
    case OCI_ERROR:
        fprintf(stderr, "Error: OCI call error.\n");
        if (type)
            (void) OCIErrorGet(errhp, 1, NULL, (sb4 *) &errcode,
(text*) msg,
                2048, OCI_HTYPE_ERROR);
        else
            (void) OCIErrorGet(errhp, 1, NULL, (sb4 *) &errcode,
(text*) msg,
                2048, OCI_HTYPE_ENV);
        fprintf(stderr, "%s\n", msg);
        break;
    case OCI_INVALID_HANDLE:
        fprintf(stderr, "Error: Invalid Handle.\n");
        if (type)
            (void) OCIErrorGet(errhp, 1, NULL, (sb4 *) &errcode,
(text*) msg,
                2048, OCI_HTYPE_ERROR);
        else
            (void) OCIErrorGet(errhp, 1, NULL, (sb4 *) &errcode,
(text*) msg,
                2048, OCI_HTYPE_ENV);
        fprintf(stderr, "%s\n", msg);
        break;
    }
    /* Rollback just in case */

    (void) OCITransRollback(tpcsvc, errhp, OCI_DEFAULT);

    fprintf(stderr, "Exiting Oracle...\n");
    fflush(stderr);

    ACIDexit();

    exit(1);
}

#ifdef LINUX
int main(argc, argv)
#else

```

## Appendix C

```

void main(argc,argv)
#ifdef
    int argc;
    char *argv[];
{
    int i;
    char line[64];
    ub4 errcode;
    char msg[2048];
    int need_commit = 0;

    /* Initialize some variables */
#ifdef LINUX
    infile=fopen("/dev/stdin","r");
#endif
    strcpy((char *) lname, "tpcd/tpcd");

    if((argc > 10) || (argc < 5)) {
        usage();
    }

    /* argv[1] -- Process Number */

    proc_no = atoi(argv[1]);

    /* argv[2] -- Number of Streams */

    num_streams = atoi(argv[2]);

    /* argv[3] -- Commit? */

    if (atoi(argv[3]) == 1)
        BIS(flag, COMMIT);

    /* argv[4] -- Delta? */

    if (atoi(argv[4]) == 1)
        BIS(flag, DELTA);

    /* Process optional parameters */

    argc -= 4;
    argv += 4;

    while(--argc) {
        ++argv;
        switch(argv[0][0]) {
            case 'u':
                strncpy((char *) lname, ++(argv[0]), UNAME_LEN);
                if (strchr((char *) lname, '/') == NULL) {
                    fprintf(stderr, "Login name must be in the format of
userid/passwd\n");
                    usage();
                    exit(-1);
                }
                break;
            case 'i':
                if ((infile = fopen(++(argv[0]), "r")) == NULL) {
                    fprintf(stderr, "Cannot open input file %s\n", argv[0]);
                    fprintf(stderr, "%s\n", strerror(errno));
                    exit(-1);
                }
                BIS(flag, INFILE);
                break;
            case 'o':
                if ((outfile = open(++(argv[0]), (O_RDWR | O_SYNC |
O_CREAT), S_IRWXU)) == -1) {
                    fprintf(stderr, "Cannot open output file %s\n", argv[0]);
                    fprintf(stderr, "%s\n", strerror(errno));
                    exit(-1);
                }
                BIS(flag, OUTFILE);
                break;
            case 'd':
                if ((logfile = open(++(argv[0]), (O_RDWR | O_SYNC |
O_CREAT), S_IRWXU)) == -1) {
                    fprintf(stderr, "Cannot open durability success file %s\n",
argv[0]);
                    fprintf(stderr, "%s\n", strerror(errno));
                    exit(-1);
                }
                BIS(flag, LOGFILE);
                break;
            case 'b':
                num_iter = atoi(++(argv[0]));
                break;
            case 't':
                trig = atoi(++(argv[0]));
                break;
            case 's':
                slp = atoi(++(argv[0]));
                break;
            default:
                fprintf(stderr, "Unknown argument %s\n", argv[0]);
                usage();
                break;
        }
    }

    FPRTF(outfile, "-----\n");

    /* Initialize the cursors etc. */

    (void) ACIDinit();

    /* sleep for some time (triggering) */

    sleep(trig);

    /* start doing the ACID transactions */

    tr_start = gettimeofday();

    /* The number of iteration we will run depends on the
number of */
    /* input lines */

```

## Appendix C

```

while (fgets(line, 64, infile) != NULL) {
#ifdef NOLKEY
    sscanf(line, "%d %d\n", &o_key, &delta);

    /* Obtain l_key from l_key query */

    OCIExec(tpcsvc,curi,errhp,1);

    /* l_key is the highest l_linenumber available. We need to
pick */
    /* at random a number between 1..l_key. */

    l_key = (int) ((lrand48() % l_key) + 1);
#else
    sscanf(line, "%d %d %d\n", &o_key, &l_key, &delta);
#endif /* NOLKEY */

    /* Generate delta if necessary */

    if (BIT(flag, DELTA))
        delta = (int) (floor((drand48() * 100)) + 1);

    /* Now, we are ready to run the ACID transaction. */

    curr_time = time(NULL);

    FPRTF2(outfile, "Starting ACID transaction %d at %s...\n",
(++num_iter),
        ctime(&curr_time));

    FPRTF1(outfile, "o_key: %d\n", (int) o_key);
    FPRTF1(outfile, "l_key: %d\n", (int) l_key);
    FPRTF1(outfile, "delta: %d\n", (int) delta);

    OCIExec(tpcsvc,curr,errhp,1);

    curr_time = time(NULL);

    if (!BIT(flag, LOGFILE)) {
        FPRTF1(outfile, "BEFORE COMMIT/ROLLBACK
TRANSACTION at %s\n", ctime(&curr_time));
        FPRTF1(outfile, "l_extendedprice: %.2f\n", l_епrice);
        FPRTF1(outfile, "l_quantity: %d\n", (int) l_quan);
        FPRTF1(outfile, "o_totalprice: %.2f\n\n", o_tprice);
    }

    FPRTF1(outfile, "Sleep %d seconds before
COMMIT/ROLLBACK...\n\n", slp);
    sleep(slp);

    /* Shall we commit? */

    if (BIT(flag, COMMIT)) {
        need_commit = 1;
        while (need_commit) {

            OCIExec(tpcsvc,curr,errhp,1);
            OCIExec(tpcsvc,curr,errhp,1);

            } else {
                need_commit = 0;
                curr_time = time(NULL);
                FPRTF2(outfile, "ACID Transaction iteration %d
COMMITTED at %s\n",
                    num_iter, ctime(&curr_time));
            }
        } else {
            OCIExec(tpcsvc,errhp);
            curr_time = time(NULL);
            FPRTF2(outfile, "ACID Transaction iteration %d
ROLLBACK at %s\n",
                num_iter, ctime(&curr_time));
        }

        /* Report all results to outfile and if necessary, to success
file. */

        /* Report initial and new values for o_totalprice,
l_extendedprice, */
        /* l_quantity. */

        /*
curr_time = time(NULL);
FPRTF1(outfile, "Transaction Completed at %s\n",
ctime(&curr_time));
*/

        /* Get the values in LINEITEM and ORDERS after the
transaction */

        if (BIT(flag, LOGFILE)) {
            FPRTF1(logfile, "p_key: %d\n", (int) l_pkey);
            FPRTF1(logfile, "s_key: %d\n", (int) l_skey);
            FPRTF1(logfile, "o_key: %d\n", (int) o_key);
            FPRTF1(logfile, "l_key: %d\n", (int) l_key);
            FPRTF1(logfile, "delta: %d\n", (int) delta);
            FPRTF1(logfile, "Transaction Completed at %s\n",
ctime(&curr_time));
            FPRTF(logfile, "-----
\n");
        } else {
            OCIExec(tpcsvc,cure1,errhp,1);
            OCIExec(tpcsvc,cure2,errhp,1);

            FPRTF(outfile, "AFTER TRANSACTION:\n");
            FPRTF1(outfile, "l_extendedprice: %.2f\n", l_newepprice);
            FPRTF1(outfile, "l_quantity: %d\n", (int) l_newquan);
            FPRTF1(outfile, "o_totalprice: %.2f\n\n", o_newtprice);
            FPRTF1(outfile, "l_tax: %.2f\n", l_tax);
            FPRTF1(outfile, "l_discount: %.2f\n", l_disc);
            FPRTF1(outfile, "rprice: %.2f\n", rprice);
            FPRTF1(outfile, "cost: %.2f\n", cost);
            FPRTF(outfile, "-----
\n");
        }
    }
}
if((status=OCITransCommit(tpcsvc,errhp,OCI_DEFAULT))
!= OCI_SUCCESS) {

```



## Appendix C

```
/* Make session serializable */

sprintf((char *) sqlstmt, ISOTXT);
OCIStmtPrepare(curi,errhp,(text *)sqlstmt,strlen((char
*)sqlstmt),
    OCI_NTV_SYNTAX,OCI_DEFAULT);
OCIExec(tpcsvc,curi,errhp,1);

/* Set optimizer_index_cost_adj = 25 */

sprintf((char *) sqlstmt, OICATXT);
OCIStmtPrepare(curi,errhp,(text *)sqlstmt,strlen((char
*)sqlstmt),
    OCI_NTV_SYNTAX,OCI_DEFAULT);
OCIExec(tpcsvc,curi,errhp,1);

curr_time = time(NULL);
printf("\nConnected to ORACLE as user: %s at %s\n\n",
lname, ctime(&curr_time));

#ifdef NOLKEY
/* Open and Parse cursor for query to choose determine
l_key. */
/* Binds l_key to :l_key. */

sprintf((char *) sqlstmt,SQLTXT1);
OCIStmtPrepare(curi,errhp,sqlstmt,strlen((char
*)sqlstmt),OCI_NTV_SYNTAX,OCI_DEFAULT);

OCIbname(curi,&l_keyi_bp,errhp,":l_key",ADR(l_key),SIZ(
l_key),SQLT_INT);

OCIbname(curi,&o_keyi_bp,errhp,":o_key",ADR(o_key),SI
Z(o_key),SQLT_INT);

#endif /* NOLKEY */

/* Open and Parse cursor for the ACID transaction. */

sprintf((char *) sqlstmt,SQLTXT2);
OCIStmtPrepare(curr,errhp,(text *)sqlstmt,strlen((char
*)sqlstmt),
    OCI_NTV_SYNTAX,OCI_DEFAULT);

/* bind variables */

OCIbname(curr,l_key_bp,errhp,":l_key",ADR(l_key),SIZ(l_
key),SQLT_INT);

OCIbname(curr,o_key_bp,errhp,":o_key",ADR(o_key),SIZ(
o_key),SQLT_INT);

OCIbname(curr,delta_bp,errhp,":delta",ADR(delta),SIZ(delt
a),SQLT_INT);

OCIbname(curr,l_pkey_bp,errhp,":l_pkey",ADR(l_pkey),SI
Z(l_pkey),SQLT_INT);

OCIbname(curr,l_skey_bp,errhp,":l_skey",ADR(l_skey),SIZ
(l_skey),SQLT_INT);

OCIbname(curr,l_quan_bp,errhp,":l_quan",ADR(l_quan),SI
Z(l_quan),SQLT_INT);

OCIbname(curr,l_newquan_bp,errhp,":l_newquan",ADR(l_n
ewquan),
    SIZ(l_newquan),SQLT_INT);

OCIbname(curr,l_tax_bp,errhp,":l_tax",ADR(l_tax),SIZ(l_t
ax),SQLT_FLT);

OCIbname(curr,l_disc_bp,errhp,":l_disc",ADR(l_disc),SIZ(
l_disc),SQLT_FLT);

OCIbname(curr,l_eprice_bp,errhp,":l_eprice",ADR(l_eprice
),SIZ(l_eprice),
    SQLT_FLT);

OCIbname(curr,l_neweprice_bp,errhp,":l_neweprice",ADR(
l_neweprice),
    SIZ(l_neweprice),SQLT_FLT);

OCIbname(curr,o_tprice_bp,errhp,":o_tprice",ADR(o_tprice
),SIZ(o_tprice),
    SQLT_FLT);

OCIbname(curr,o_newtprice_bp,errhp,":o_newtprice",ADR(
o_newtprice),
    SIZ(o_newtprice), SQLT_FLT);

OCIbname(curr,rprice_bp,errhp,":rprice",ADR(rprice),SIZ(r
price), SQLT_FLT);
OCIbname(curr,cost_bp,errhp,":cost",ADR(cost),SIZ(cost),
SQLT_FLT);

/* Open & Parse cursor for end values query */

sprintf((char *) sqlstmt,SQLTXT3);
OCIStmtPrepare(cure1,errhp,(text *)sqlstmt,strlen((char
*)sqlstmt),
    OCI_NTV_SYNTAX,OCI_DEFAULT);

sprintf((char *) sqlstmt,SQLTXT4);
OCIStmtPrepare(cure2,errhp,(text *)sqlstmt,strlen((char
*)sqlstmt),
    OCI_NTV_SYNTAX,OCI_DEFAULT);

/* bind variables */

OCIbname(cure1,l_neweprice1_bp,errhp,":l_neweprice",AD
R(l_neweprice),
```

## Appendix C

```
SIZ(l_neweprice),SQLT_FLT);

OCIbbname(cure1,l_newquan1_bp,errhp,":l_newquan",ADR(
l_newquan),
    SIZ(l_newquan),SQLT_INT);

OCIbbname(cure1,o_key1_bp,errhp,":o_key",ADR(o_key),SI
Z(o_key),SQLT_INT);

OCIbbname(cure1,l_key1_bp,errhp,":l_key",ADR(l_key),SIZ
(l_key),SQLT_INT);

OCIbbname(cure2,o_newtprice2_bp,errhp,":o_newtprice",AD
R(o_newtprice),
    SIZ(o_newtprice),SQLT_FLT);

OCIbbname(cure2,o_key2_bp,errhp,":o_key",ADR(o_key),SI
Z(o_key),SQLT_INT);

}
```

### **atranspl.h**

```
/* Copyright (c) 2001, 2002, Oracle Corporation. All rights
reserved. */
```

```
/*
```

```
NAME
atranspl.h - <one-line expansion of the name>
```

#### DESCRIPTION

#### MODIFIED (MM/DD/YY)

```
mpoess 10/23/02 - mpoess_update_from_visa
mpoess 10/17/01 - add TXT parameter
mpoess 04/09/01 - add hint to find max linenumber
mpoess 01/04/01 - Creation
```

```
*/
```

```
#ifndef ATRANSPL_H
```

```
#define ATRANSPL_H
```

```
#include <stdio.h>
#include <stdlib.h>
#include <string.h>
#include <sys/param.h>
#include <sys/types.h>
#include <time.h>
#include <errno.h>
#include <math.h>
```

```
#include <oratypes.h>
#ifndef OCIDFN
#include <ocidfn.h>
#endif /* OCIDFN */
```

```
#ifndef OCI_ORACLE
```

```
#include <oci.h>
#endif /* OCI_ORACLE */

/*
#ifdef __STDC__
#include <ociapr.h>
#else
#include <ocikpr.h>
#endif /* __STDC__ */
```

```
extern int errno;
```

```
#ifndef NULL
#define NULL 0
#endif
```

```
#ifndef NULLP
#define NULLP (void *)NULL
#endif /* NULLP */
```

```
#ifndef DISCARD
#define DISCARD (void)
#endif
```

```
#ifndef sword
#define sword int
#endif
```

```
#ifndef ub1
#define ub1 unsigned char
#endif
```

```
#define UNAME_LEN 64
#define WRITE_BUF_LEN 1024
```

```
#define NA -1 /* ANSI SQL NULL */
#define VER7 2
#define NOT_SERIALIZABLE 8177 /* ORA-08177:
transaction not serializable */
#define WRITE_BUF_LEN 1024
```

```
#define ADR(object) ((ub1 *)&(object))
#define SIZ(object) ((sword)sizeof(object))
#define BIS(flag,mask) (unsigned) (flag |= (unsigned) mask)
#define BIT(flag,mask) (unsigned) ((unsigned) flag &
(unsigned) mask)
```

```
#define FPRTF(fd,s) \
{sprintf(buf,s); write(fd, buf, strlen(s));}
#define FPRTF1(fd,s,p) \
{sprintf(buf,s,p); write(fd, buf, strlen(buf));}
#define FPRTF2(fd,s,p1,p2) \
{sprintf(buf,s,p1,p2); write(fd, buf, strlen(buf));}
```

```
#define OCIhalloc(envh,hndl,htyp) \
if((status=OCIHandleAlloc((dvoid *)envh,(dvoid
**)hndl,htyp,0,(dvoid **)0))!=OCI_SUCCESS) \
sql_error(envh,status,0); \
else \
```

## Appendix C

DISCARD 0

```
#define OCIfree(hndl,htyp) \
    if((status=OCIHandleFree((dvoid *)hndl,htyp)) ==
OCI_SUCCESS) \
    fprintf(stderr, "Error freeing handle of type %d\n", htyp)

#define OCIfget(hndl,htyp,attp,size,atyp,errh) \
    if((status=OCIAttrGet((dvoid *)hndl,htyp,(dvoid
*)attp,(dvoid *)size,atyp,errh)) != OCI_SUCCESS) \
    sql_error(errh,status,1); \
    else \
    DISCARD 0

#define OCIfset(hndl,htyp,attp,size,atyp,errh) \
    if((status=OCIAttrSet((dvoid *)hndl,htyp,(dvoid
*)attp,size,atyp,errh)) != OCI_SUCCESS) \
    sql_error(errh,status,1); \
    else \
    DISCARD 0

#define OCIfexec(svch,stmh,errh,iter) \

if((status=OCISmtExecute(svch,stmh,errh,iter,0,NULL,NUL
L,OCI_DEFAULT)) != OCI_SUCCESS) \
    sql_error(errh,status,1); \
    else \
    DISCARD 0

#define
OCIbname(stmh,bindp,errh,sqlvar,progv,progv1,ftype) \
    if((status=OCIBindByName(stmh,&bindp,errh,(text
*)sqlvar,strlen(sqlvar), \
        progv,progv1,ftype,0,0,0,0,OCI_DEFAULT)) !=
OCI_SUCCESS) \
    sql_error(errh,status,1); \
    else \
    DISCARD 0

#define
OCIbnamei(stmh,bindp,errh,sqlvar,progv,progv1,ftype,indp)
\
    if((status=OCIHandleAlloc((dvoid *)stmh,(dvoid
**)&bindp,OCI_HTYPE_BIND, \
        0,(dvoid **)0))!=OCI_SUCCESS) \
    sql_error(stmh,status,0); \
    if((status=OCIBindByName(stmh,&bindp,errh,(text
*)sqlvar,strlen(sqlvar), \
        progv,progv1,ftype,indp,0,0,0,OCI_DEFAULT))
!= OCI_SUCCESS) \
    sql_error(errh,status,1); \
    else \
    DISCARD 0

#define OCIfcom(svcp,errh) \
    if((status=OCITransCommit(svcp,errh,OCI_DEFAULT))
!= OCI_SUCCESS) \
    sql_error(errh,status,1); \
    else \
```

DISCARD 0

```
#define OCIfrol(svcp,errh) \
    if((status=OCITransRollback(svcp,errh,OCI_DEFAULT))
!= OCI_SUCCESS) \
    sql_error(errh,status,1); \
    else \
    DISCARD 0

#define ISOTXT "alter session set isolation_level =
serializable"
#define PDMLTXT "alter session force parallel dml parallel
(degree 2)"
#define PDDLTX "alter session force parallel ddl parallel
(degree 2)"
#define OICATXT "alter session set
optimizer_index_cost_adj=25"

#define SQLTXT1 "BEGIN SELECT /*+
index(lineitem,i_l_orderkey) */MAX(l_linenumber) INTO
:l_key FROM lineitem \
WHERE l_orderkey = :o_key; END;"

#define SQLTXT2 "BEGIN d_atrans.doatrans(:l_key, :o_key,
:delta, :l_pkey, \
:l_skey, :l_quan, :l_newquan, :l_tax, :l_disc, :l_eprice,
:l_neweprice, \
:o_tprice, :o_newtprice, :rprice, :cost); END;"

#define SQLTXT3 "BEGIN SELECT l_extendedprice,
l_quantity \
INTO :l_neweprice, :l_newquan \
FROM lineitem \
WHERE l_orderkey = :o_key \
AND l_linenumber = :l_key; END;"

#define SQLTXT4 "BEGIN SELECT o_totalprice INTO
:o_newtprice \
FROM orders \
WHERE o_orderkey = :o_key; END;"

#define SQLTXT5 "BEGIN SELECT l_extendedprice,
l_quantity \
INTO :l_eprice, :l_quan \
FROM lineitem \
WHERE l_orderkey = :o_key \
AND l_linenumber = :l_key; END;"

#define SQLTXT6 "BEGIN SELECT o_totalprice INTO
:o_tprice \
FROM orders \
WHERE o_orderkey = :o_key; END;"

#endif /* ATRANSPL_H */

ckpt.sh
#!/bin/ksh
#
# $Header: ckpt.sh 08-aug-99.17:32:22 mpoess Exp $
```

## Appendix C

```
#
# ckpt.sh
#
# Copyright (c) Oracle Corporation 1999. All Rights
Reserved.
#
# NAME
# ckpt.sh - <one-line expansion of the name>
#
# DESCRIPTION
# <short description of component this file
declares/defines>
#
# NOTES
# <other useful comments, qualifications, etc.>
#
# MODIFIED (MM/DD/YY)
# mpoess 08/08/99 - Creation
# mpoess 08/08/99 - Creation
#
. $KIT_DIR/env
sqlplus -s /NOLOG << !

    connect / as sysdba;
    alter system switch logfile;
    alter system switch logfile;
    exit;
!

consist.sh
#!/bin/ksh
#
# $Header: consist.sh 08-aug-99.14:20:51 mpoess Exp $
#
# consist.sh
#
# Copyright (c) Oracle Corporation 1999. All Rights
Reserved.
#
# NAME
# consist.sh - <one-line expansion of the name>
#
# DESCRIPTION
# Performs consistency tests.
# Usage: consist.sh [-n iter] [-s number of stream] [-p prog]
# [-u usr/pswd] -h
#
# Options: See usage below
#
# NOTES
# <other useful comments, qualifications, etc.>
#
# MODIFIED (MM/DD/YY)
# mpoess 08/08/99 - Creation
# mpoess 08/08/99 - Creation
#
. $KIT_DIR/env
```

```
OH=$ORACLE_HOME
# ACID_DIR=$TPCD_KIT_DIR/audit set in env
OUT_DIR=$ACID_OUT

KEY=$OUT_DIR/key$$_
OUTFILE=${OUT_DIR}/consrte
CON1=${OUT_DIR}/conb
CON2=${OUT_DIR}/cona
CHK=${OUT_DIR}/conskcpt

/bin/rm -rf ${KEY}* $CON1 $CON2 $OUTFILE $CHK

trap "/bin/rm -rf ${KEY}*; exit 1" 1 2 3 15

STREAM=${NUM_STREAMS}
let STREAM="$STREAM + 1" # add one for the update
stream
ITER=100
PROG=atranspl
USER=${DATABASE_USER}
CK=10

usage() {
    echo ""
    echo "Usage: $0 [-n iter] [-s number of stream] [-p prog] [-u
usr/pswd] -h"
    echo ""
    echo "-n iter          : number of iterations, default is 100"
    echo "-s number of stream : number of streams, default is 2"
    echo "-p prog           : program to run, default is
atranspl.ott"
    echo "-u usr/pswd      : user/password for database access,
default is tpcd/tpcd"
    echo "-t chkpt        : time after the start of ACID
transaction to perform the checkpoint"
    echo "                default is 10 seconds"
    echo "-h              : print this usage summary"
    exit 1;
}

set -- `getopt "n:p:u:s:h" "$@"` || usage

while :
do
    case "$1" in
-s) shift; STREAM=$1;;
-n) shift; ITER=$1;;
-p) shift; PROG=$1;;
-u) shift; USER=$1;;
-t) shift; CK=$1;;
-h) usage; exit 0;;
--) break;;
    esac
    shift
done

if [ $ITER -lt 100 ]
```



## Appendix C

```
then
echo "Error: Must at least run 100 iterations!"
echo "Exiting..."
exit 1
fi

if [ $STREAM -lt 2 ]
then
echo "Error: Must at least run 2 streams!"
echo "Exiting..."
exit 1
fi

echo "Starting Consistency Test at `date` ..."
echo ""
echo "Generate some keys first"
echo ""

i=0

while [ $i -lt $STREAM ]
do
echo randkey $ITER 1 u$USER
randkey $ITER 1 u$USER > ${KEY}$i
i=`expr $i + 1`
done

echo "Check consistency before Submitting Transactions
`date`"
echo "Check consistency before Submitting Transactions
`date`" >> $CON1

echo "Obtain 10 keys from the each key file to check
consistency"

i=0
while [ $i -lt $STREAM ]
do
KEYS=`head -10 ${KEY}$i | awk '{printf "%d ", $1}'`
echo "The 10 Keys for file $i are: $KEYS"
# for j in `head -10 ${KEY}$i | awk '{printf "%d ", $1}'`
for j in $KEYS
do
sqlplus $USER @consist $j >> $CON1
echo "-----" >> $CON1
done
i=`expr $i + 1`
done

echo ""
echo "Starting ACID transactions at `date`"
echo ""

i=0

while [ $i -lt $STREAM ]
do
$PROG $i $STREAM 1 0 u${USER} i${KEY}$i
o${OUTFILE}$i s1 &
i=`expr $i + 1`
done

echo "Schedule a Checkpoint"
echo "Checkpoint scheduled at $CK seconds after `date`"

(sleep $CK; $ACID_DIR/ckpt.sh) &

wait

echo ""
echo "Ending ACID transactions at `date`"
echo ""

echo "Completed $STREAM transaction streams with $ITER
iterations each"
echo ""

echo "Check consistency after Submitting Transactions
`date`"
echo "Check consistency after Submitting Transactions
`date`" >> $CON2

cat
${ORACLE_HOME}/rdbms/log/alert_${ORACLE_SID}.log
>> $CHK

i=0
while [ $i -lt $STREAM ]
do
KEYS=`head -10 ${KEY}$i | awk '{printf "%d ", $1}'`
# for j in `head -10 ${KEY}$i | awk '{printf "%d ", $1}'`
echo "The keys to check for consistency after the test from file
$i are:"
echo "$KEYS"
for j in $KEYS
do
sqlplus $USER @consist $j >> $CON2
echo "-----" >> $CON2
done
i=`expr $i + 1`
done

consist.sql
Rem
Rem $Header: consist.sql 08-aug-99.16:59:17 mpoess Exp $
Rem
Rem consist.sql
Rem
Rem Copyright (c) Oracle Corporation 1999. All Rights
Reserved.
Rem
Rem NAME
Rem consist.sql - <one-line expansion of the name>
Rem
Rem DESCRIPTION
Rem Verifies the consistency of TPC-D database using the
Rem consistency condition.
Rem
```

## Appendix C

```
Rem Usage: sqlplus tpcd/tpcd @consist
Rem
Rem NOTE
Rem REQUIRES PACKAGES prvtotpt and dbmsotpt
rem
Rem MODIFIED (MM/DD/YY)
Rem mpoess 08/08/99 - Creation
Rem mpoess 08/08/99 - Created
Rem

set verify off
rem set termout on
rem set echo on

REM
REM Get today's date.
REM

select
substr(TO_CHAR(sysdate,'YYYY-MM-DD
HH:MI:SS'),1,20) as CURRENT_TIME
from dual;

set serverout on;

DECLARE
    o_okey    number;
    o_tprice number;
    l_tprice number;
    diff      number;
BEGIN
    select o_totalprice
    into o_tprice
    from orders
    where o_orderkey = &&1;

    select sum(trunc((trunc((l_extendedprice * (1-l_discount)),
2)
    * (1+l_tax)), 2))
    into l_tprice
    from lineitem
    where l_orderkey = &&1;

    diff := l_tprice - o_tprice;

    dbms_output.put_line('O_TOTALPRICE: ' ||
TO_CHAR(trunc(o_tprice,2)));
    dbms_output.put_line('L_TOTALPRICE: ' ||
TO_CHAR(trunc(l_tprice,2)));
    dbms_output.put_line('Difference: ' ||
TO_CHAR(trunc(diff,2)));

END;
/
```

```
spool off
exit

dura.sh
#!/bin/ksh
#
# $Header: dura.sh 08-aug-99.15:21:38 mpoess Exp $
#
# dura.sh
#
# Copyright (c) Oracle Corporation 1999. All Rights
Reserved.
#
# NAME
#   dura.sh - <one-line expansion of the name>
#
# DESCRIPTION
#   <short description of component this file
declares/defines>
#
# NOTES
#   <other useful comments, qualifications, etc.>
#
# MODIFIED (MM/DD/YY)
#   mpoess 08/08/99 - Creation
#   mpoess 08/08/99 - Creation
#

.SKIT_DIR/env

# Create history table

# Count number of entries in the history table
SERVER="ultraperf2"

echo "-----"
echo "Capturing Process information before durability tests
`date`"
rsh $SERVER -n -l spyda ps -ef; date
echo "-----"

echo "-----"
echo "Starting the durability tests `date`"
run_acid.sh &
echo "-----"

sleep 1200

echo "-----"
echo "Collecting user information. `date`"
./cnt_user.sh pswong spyda ultraperf2 > dura/duraucnt 2>&1
echo "-----"

echo "-----"
echo "Capturing Process information while running
Transactions `date`"
rsh $SERVER -n -l spyda ps -ef; date
echo "-----"
```

## Appendix C

```
echo "-----"
echo "Capturing disk information on Server: Ultraperf2
`date`"
rsh $$SERVER -n -l spyda vxprint -ht ; date
echo "-----"

echo "-----"
echo "Detaching mirror on data disk. `date`"
rsh $$SERVER -n -l root "vxplex -v ordr23 det ordr23-01"
echo "-----"

echo "-----"
echo "Capturing Disk information information on Server:
Ultraperf2 `date`"
rsh $$SERVER -n -l spyda vxprint -ht ; date
echo "-----"

sleep 120

echo "-----"
echo "Capturing Process information after breaking data
mirror. `date`"
rsh $$SERVER -n -l spyda ps -ef; date
echo "-----"

echo "-----"
echo "Detaching mirror on log2 disk. `date`"
rsh $$SERVER -n -l root "vxplex -v log2 det log2-01"
echo "-----"

echo "-----"
echo "Capturing Disk information information on Server:
Ultraperf2 `date`"
rsh $$SERVER -n -l spyda vxprint -ht ; date
echo "-----"

sleep 120

echo "-----"
echo "Capturing Process information after detaching log
mirror. `date`"
rsh $$SERVER -n -l spyda ps -ef; date
echo "-----"

# Power Off

end_acid.sh

#!/bin/ksh
#
# $Header: end_acid.sh 08-aug-99.17:06:20 mpoess Exp $
#
# end_acid.sh
#
# Copyright (c) Oracle Corporation 1999. All Rights
Reserved.
#
```

```
# NAME
# end_acid.sh - <one-line expansion of the name>
#
# DESCRIPTION
# end_cons.sh <pid of the durability run>
# Options: See usage below
#
# NOTES
# <other useful comments, qualifications, etc.>
#
# MODIFIED (MM/DD/YY)
# mpoess 08/08/99 - Creation
# mpoess 08/08/99 - Creation
#

.SKIT_DIR/env

OH=$ORACLE_HOME
# ACID_DIR=$OH/tpcd/audit set in env
OUT_DIR=$ACID_OUT/
DURA_DIR=$ACID_OUT/dura
RUN_ID_FILE=$ACID_DIR/run_id

SHELL_PID=`cat ${DURA_DIR}/shellpid`
ITER=100
STEM=${NUM_STREAMS}
let STEM="$STEM + 1" # add one for the update stream
PROG=${ACID_DIR}/atranspl.ott
IN=${ACID_DIR}/acid_in
DURA=${DURA_DIR}/drate
OUT=${DURA_DIR}/drate
DSMPL=${DURA_DIR}/durasmpl
KEY=${DURA_DIR}/key${SHELL_PID}_
USER=tpch/tpch
TRIG=1
HCNT=duracnta

# get history count

sqlplus $USER @cnt_hist > $DURA_DIR/$HCNT 2>&1

# perform the consistency

i=0
while [ $i -lt $STEM ]
do
  for j in `head -10 ${KEY}${i} | awk '{printf "%d ",$1}'`
  do
    sqlplus tpch/tpch @consist $j >> $DURA_DIR/duraconsa
  done
  i=`expr $i + 1`
done

i=0
while [ $i -lt $STEM ]
do
  sample.sh $DURAS${i} > ${DSMPL}${i} 2>&1
  i=`expr $i + 1`
done
```

## Appendix C

```
gettime.c
#ifdef RCSID
static char *RCSid =
"$Header: gettime.c 15-jul-99.14:27:44 mpoess Exp $ ";
#endif /* RCSID */

/* Copyright (c) Oracle Corporation 1999. All Rights
Reserved. */

/*

NAME
    gettime.c

DESCRIPTION
    get wall clock time.
    get cpu time.

FUNCTIONS
    get wall clock time.
    get cpu time.

NOTES
    Both routines return time in seconds as a double.
MODIFIED (MM/DD/YY)
    mpoess 07/15/99 - Creation
    mpoess 07/15/99 - Creation

*/

/*
** Options:
** TIME_W_TIMES:    implement gettime() with times().
** TIME_W_GETTIME:  implement gettime() with
gettimeofday().
** CPU_W_TIMES:     implement getcpu() with times().
** CPU_W_GETTRU:    implement getcpu() with
getrusage().
** GETRU_STATS:     collect getrusage statistics
** GET_P_STATS:     collect get_process_stats statistics
*/

#define SUN_OS5

#ifdef SUN_OS5
#define TIME_W_GETTIME
#define CPU_W_TIMES
#undef GETRU_STATS
#undef CPU_W_GETTRU
#endif /* SUN_OS5 */

#ifdef sequent || defined(SEQ_PSX)
#define GET_P_STATS
#endif /* sequent */

#ifdef aix || defined(AIXRIOS)
```

```
# define TIME_W_GETTIME
# define CPU_W_TIMES
# define GETRU_STATS
#endif /* AIXRIOS */

#ifdef a_osf || defined(A_OSF)
# define TIME_W_GETTIME
# define CPU_W_GETTRU
# define GETRU_STATS
#endif /* AIXRIOS */

#ifdef HPUX || defined(XENIX_386) ||
defined(SYSV_386) || defined(ATT_3B)
# define TIME_W_TIMES
# define CPU_W_TIMES
#endif /* HPUX || XENIX_386 || SYSV_386 */

#ifdef !defined(TIME_W_GETTIME) &&
!defined(TIME_W_TIMES)
# define TIME_W_TIMES
#endif

#ifdef !defined(CPU_W_GETTRU) &&
!defined(CPU_W_TIMES)
# define CPU_W_TIMES
#endif

#ifdef GET_P_STATS
# undef GETRU_STATS
# endif
#endif

#ifdef TIME_W_GETTIME ||
defined(CPU_W_GETTRU) || defined(GETRU_STATS)
# include <sys/time.h>
#endif /* TIME_W_GETTIME || CPU_W_GETTRU ||
GETRU_STATS */

#ifdef CPU_W_GETTRU || defined(GETRU_STATS)
# include <sys/resource.h>
#endif /* CPU_W_GETTRU || GETRU_STATS */

#ifdef TIME_W_TIMES || defined(CPU_W_TIMES)
# include <sys/types.h>
# include <sys/times.h>
# include <sys/param.h> /* most systems define HZ here */
#endif /* TIME_W_TIMES or CPU_W_TIMES */

#ifdef GET_P_STATS
# include <sys/types.h>
# include <sys/procstats.h>
#endif /* GET_P_STATS */

# include <stdio.h>

#ifdef GETRU_STATS
struct rusage selfru;
struct rusage kidsru;
```

## Appendix C

```
#endif /* GETRU_STATS */

#ifdef GET_P_STATS
struct process_stats selfru;
struct process_stats kidsru;
#endif /* GET_P_STATS */

double gettime ()

{
#ifdef TIME_W_GETTIME
    struct timeval tv;

    (void) gettimeofday (&tv, (struct timezone *) 0);
    return ((double) tv.tv_sec + (1.0e-6 * (double) tv.tv_usec));
#endif /* TIME_W_GETTIME */

#ifdef TIME_W_TIMES
    struct tms buf;

    return ((double) times (&buf) / HZ);
#endif /* TIME_W_TIMES */
}

double getcpu ()

{
#ifdef CPU_W_TIMES
    struct tms buf;

    (void) times (&buf);
    return (((double) buf.tms_utime + (double) buf.tms_stime) /
    HZ);
#endif /* CPU_W_TIMES */

#ifdef CPU_W_GETRU
    struct rusage ru;
    double usecs;

    (void) getrusage (0, &ru);
    usecs = 1.0e-6 * (double) (ru.ru_utime.tv_usec +
    ru.ru_stime.tv_usec);
    return ((double) (ru.ru_utime.tv_sec + ru.ru_stime.tv_sec) +
    usecs);
#endif /* CPU_W_GETRU */
}

getru (fp, kids, config, runname, proc_no)

FILE *fp;
int kids;
char *config;
char *runname;
int proc_no;

{
#ifdef GETRU_STATS
    struct rusage ru;

    fprintf (fp, "%-10.10s %-10.10s %10d %10d ",
    config, runname, proc_no, kids);
    getrusage (kids ? RUSAGE_CHILDREN :
    RUSAGE_SELF, &ru);
    print_ru (fp, &ru);
    fprintf (fp, "\n");
#endif /* GETRU_STATS */

#ifdef GET_P_STATS
    timeval_t tv;
    struct process_stats ru;

    fprintf (fp, "%-10.10s %-10.10s %10d %10d ",
    config, runname, proc_no, kids);
    if (kids)
        get_process_stats (&tv, PS_SELF, (struct process_stats *)
    0, &ru);
    else
        get_process_stats (&tv, PS_SELF, &ru, (struct
    process_stats *) 0);
    print_ru (fp, &ru);
    fprintf (fp, "\n");
#endif /* GET_P_STATS */
}

getru1 (kids)

int kids;

{
#ifdef GETRU_STATS
    if (kids) {
        memset (&kidsru, 0, sizeof (kidsru));
        getrusage (RUSAGE_CHILDREN, &kidsru);
    }
    else {
        memset (&selfru, 0, sizeof (selfru));
        getrusage (RUSAGE_SELF, &selfru);
    }
#endif /* GETRU_STATS */

#ifdef GET_P_STATS
    timeval_t tv;

```

## Appendix C

```

if (kids) {
    memset (&kidsru, 0, sizeof (kidsru));
    get_process_stats (&tv, PS_SELF, (struct process_stats *)
0, &kidsru);
}
else {
    memset (&selfru, 0, sizeof (selfru));
    get_process_stats (&tv, PS_SELF, &selfru, (struct
process_stats *) 0);
}
#endif /* GET_P_STATS */
}

getru2 (fp, kids, config, runname, proc_no)

FILE *fp;
int kids;
char *config;
char *runname;
int proc_no;

{
#ifdef GETRU_STATS
    struct rusage ru;

    fprintf (fp, "%-10.10s %-10.10s %10d %10d ", config,
runname, proc_no, kids);
    getrusage (kids ? RUSAGE_CHILDREN :
RUSAGE_SELF, &ru);
    if (kids)
        diffru (&ru, &kidsru);
    else
        diffru (&ru, &selfru);
    print_ru (fp, &ru);
    fprintf (fp, "\n");
#endif /* GETRU_STATS */

#ifdef GET_P_STATS
    timeval_t tv;
    struct process_stats ru;

    fprintf (fp, "%-10.10s %-10.10s %10d %10d ", config,
runname, proc_no, kids);
    if (kids)
        get_process_stats (&tv, PS_SELF, (struct process_stats *)
0, &ru);
    else
        get_process_stats (&tv, PS_SELF, &ru, (struct
process_stats *) 0);
    if (kids)
        diffru (&ru, &kidsru);
    else
        diffru (&ru, &selfru);
    print_ru (fp, &ru);
    fprintf (fp, "\n");
#endif /* GET_P_STATS */
}

#endif /* GET_P_STATS */
}

fprintf (fp, "%10ld ", ru->ru_utime.tv_sec * 1000 +
(ru->ru_utime.tv_usec/1000));
fprintf (fp, "%10ld ", ru->ru_stime.tv_sec * 1000 +
(ru->ru_stime.tv_usec/1000));
fprintf (fp, "%10ld ", ru->ru_maxrss);
fprintf (fp, "%10ld ", ru->ru_majflt);
fprintf (fp, "%10ld ", ru->ru_minflt);
fprintf (fp, "%10ld ", 0);
fprintf (fp, "%10ld ", 0);
fprintf (fp, "%10ld ", 0);
fprintf (fp, "%10ld ", ru->ru_nswap);
fprintf (fp, "%10ld ", 0);
fprintf (fp, "%10ld ", ru->ru_nvcsw);
fprintf (fp, "%10ld ", ru->ru_nivcsw);
fprintf (fp, "%10ld ", ru->ru_nsignals);
fprintf (fp, "%10ld ", 0);
fprintf (fp, "%10ld ", 0);
fprintf (fp, "%10ld ", ru->ru_inblock);
fprintf (fp, "%10ld ", ru->ru_oublock);
fprintf (fp, "%10ld ", 0);
fprintf (fp, "%10ld", 0);
}

diffru (ru2, ru)

struct rusage *ru2;
struct rusage *ru;

{
    ru2->ru_utime.tv_sec -= ru->ru_utime.tv_sec;
    ru2->ru_utime.tv_usec -= ru->ru_utime.tv_usec;
    ru2->ru_stime.tv_sec -= ru->ru_stime.tv_sec;
    ru2->ru_stime.tv_usec -= ru->ru_stime.tv_usec;
    ru2->ru_maxrss -= ru->ru_maxrss;
    ru2->ru_ixrss -= ru->ru_ixrss;
    ru2->ru_idrss -= ru->ru_idrss;
    ru2->ru_minflt -= ru->ru_minflt;
    ru2->ru_majflt -= ru->ru_majflt;
    ru2->ru_nswap -= ru->ru_nswap;
    ru2->ru_inblock -= ru->ru_inblock;
}

```

## Appendix C

```
ru2->ru_oublock -= ru->ru_oublock;
ru2->ru_msgsnd -= ru->ru_msgsnd;
ru2->ru_msgrcv -= ru->ru_msgrcv;
ru2->ru_nsignals -= ru->ru_nsignals;
ru2->ru_nvesw -= ru->ru_nvesw;
ru2->ru_nivcsw -= ru->ru_nivcsw;
}

#endif /* GETRU_STATS */

#ifdef GET_P_STATS

print_ru (fp, ps)

FILE *fp;
struct process_stats *ps;

{

    fprintf (fp, "%lu ", ps->ps_otime.tv_sec * 1000 +
             (ps->ps_otime.tv_usec/1000));
    fprintf (fp, "%lu ", ps->ps_stime.tv_sec * 1000 +
             (ps->ps_stime.tv_usec/1000));
    fprintf (fp, "%lu ", ps->ps_maxrss);
    fprintf (fp, "%lu ", ps->ps_pagein);
    fprintf (fp, "%lu ", ps->ps_reclaim);
    fprintf (fp, "%lu ", ps->ps_zerofill);
    fprintf (fp, "%lu ", ps->ps_pffincr);
    fprintf (fp, "%lu ", ps->ps_pffdecr);
    fprintf (fp, "%lu ", ps->ps_swap);
    fprintf (fp, "%lu ", ps->ps_syscall);
    fprintf (fp, "%lu ", ps->ps_volcsw);
    fprintf (fp, "%lu ", ps->ps_involcsw);
    fprintf (fp, "%lu ", ps->ps_signal);
    fprintf (fp, "%lu ", ps->ps_lread);
    fprintf (fp, "%lu ", ps->ps_lwrite);
    fprintf (fp, "%lu ", ps->ps_bread);
    fprintf (fp, "%lu ", ps->ps_bwrite);
    fprintf (fp, "%lu ", ps->ps_phread);
    fprintf (fp, "%lu", ps->ps_phwrite);
}

diffru (ru2, ru)

struct process_stats *ru2;
struct process_stats *ru;

{

    ru2->ps_otime.tv_sec -= ru->ps_otime.tv_sec;
    ru2->ps_otime.tv_usec -= ru->ps_otime.tv_usec;
    ru2->ps_stime.tv_sec -= ru->ps_stime.tv_sec;
    ru2->ps_stime.tv_usec -= ru->ps_stime.tv_usec;
```

```
ru2->ps_maxrss -= ru->ps_maxrss;
ru2->ps_pagein -= ru->ps_pagein;
ru2->ps_reclaim -= ru->ps_reclaim;
ru2->ps_zerofill -= ru->ps_zerofill;
ru2->ps_pffincr -= ru->ps_pffincr;
ru2->ps_pffdecr -= ru->ps_pffdecr;
ru2->ps_swap -= ru->ps_swap;
ru2->ps_syscall -= ru->ps_syscall;
ru2->ps_volcsw -= ru->ps_volcsw;
ru2->ps_involcsw -= ru->ps_involcsw;
ru2->ps_signal -= ru->ps_signal;
ru2->ps_lread -= ru->ps_lread;
ru2->ps_lwrite -= ru->ps_lwrite;
ru2->ps_bread -= ru->ps_bread;
ru2->ps_bwrite -= ru->ps_bwrite;
ru2->ps_phread -= ru->ps_phread;
ru2->ps_phwrite -= ru->ps_phwrite;
}

#endif /* GET_P_STATS */
```

#endif /\* GET\_P\_STATS \*/

### gtime.c

/\* Copyright (c) 2001, 2002, Oracle Corporation. All rights reserved. \*/

/\*

#### NAME

gtime.c - <one-line expansion of the name>

#### DESCRIPTION

<short description of facility this file declares/defines>

#### EXPORT FUNCTION(S)

<external functions defined for use outside package - one-line descriptions>

#### INTERNAL FUNCTION(S)

<other external functions defined - one-line descriptions>

#### STATIC FUNCTION(S)

<static functions defined - one-line descriptions>

#### NOTES

<other useful comments, qualifications, etc.>

#### MODIFIED (MM/DD/YY)

mposs 10/23/02 - mposs\_update\_from\_visa

mposs 08/29/01 - Creation

\*/

#include<stdio.h>

#include<stdlib.h>

# include <sys/time.h>

main ()

{

## Appendix C

```
struct timeval tv;

(void) gettimeofday (&tv, (struct timezone *) 0);

printf ("%0.2f\n", ((double) tv.tv_sec + (1.0e-6 * (double)
tv.tv_usec)) );
}

/* end of file gtime.c */
```

### iso1.sh

```
#!/bin/ksh
#
# $Header: iso1.sh 29-jul-98.17:00:11 akarasik Exp $
#
# iso1.sh
#
# Copyright (c) Oracle Corporation 1998. All Rights
Reserved.
#
# NAME
#   iso1.sh
#
# DESCRIPTION
#   Usage: iso1.sh [-u user/password] [-n remote_node] -h
#   Options: See usage below
# NOTES
#   For a cross node isolation test, assume the local node
is
#   one of the participating nodes. The other node can
be
#   specified by the -n option.
#   You need to set the environment variable
TPCD_KIT_DIR
#
# MODIFIED (MM/DD/YY)
# mpoess 12/16/98 - update to version 8.1.6
# mpoess 09/25/98 - update audit
# akarasik 07/29/98 -
# akarasik 07/29/98 - Creation
#

. $KIT_DIR/env

# May need to change the following:
RSH=ssh

OH=$ORACLE_HOME
#ACID_DIR=$KIT_DIR/acid is set in env
OUT_DIR=$ACID_OUT

TXN1FILE=$OUT_DIR/txn1$$$.out
TXN2FILE=$OUT_DIR/txn2$$$.out
KEYFILE=$OUT_DIR/key$$$.out
ISOFILE=$OUT_DIR/iso1
```

```
USER=$DATABASE_USER
PROG=atranspl
```

```
/bin/rm -rf $TXN1FILE $TXN2FILE $KEYFILE
```

```
trap "/bin/rm -rf $TXN1FILE $TXN2FILE $KEYFILE; exit
1" 1 2 3 15
```

```
usage() {
    echo ""
    echo "Usage: $0 [-u user/passwd] [-n remote_node] -h"
    echo ""
    exit 1;
}
```

```
set -- `getopt "u:n:h" "$@"` || usage
```

```
while :
do
    case "$1" in
        -u) shift; USER=$1;;
        -n) shift; HOST="$1";;
        -h) usage; exit 0;;
        --) break;;
    esac
    shift;
done
```

```
de=`direxists.sh $ACID_OUT c` # I am not using $de
afterward, but I want to avoid the output of direxists
```

```
# generate key files
```

```
randkey 1 0.1 u"$USER" > $KEYFILE
```

```
OKEY=`cat $KEYFILE | awk '{print $1}'`
echo "o_key is "$OKEY
```

```
# before the ACID transaction, let's run a ACID query to
record the
# initial state of lineitem
```

```
echo "Running ACID query BEFORE the start of Isolation
Test 1" >> $TXN2FILE
echo "`date`" >> $TXN2FILE
echo "" >> $TXN2FILE
sqlplus $USER @$ACID_DIR/isolation/a_query $OKEY >>
$TXN2FILE
echo "" >> $TXN2FILE
echo "-----" >>
$TXN2FILE
```

```
sleep 1
```

```
# start ACID transaction, Sleep for 60 second before
COMMIT
```



## Appendix C

```
$PROG 1 1 1 0 i$KEYFILE u$USER s60 b0 >> $TXN1FILE
&
```

```
# let's sleep 10 seconds before starting ACID query
```

```
sleep 15
```

```
# start ACID query with the same OKEY
```

```
echo "Running ACID query 15 seconds AFTER the start of
ACID Transaction" \
>> $TXN2FILE
echo "`date`" >> $TXN2FILE
if [ "$HOST" != "" ]
then
echo "Starting ACID query on node $HOST" >> $TXN2FILE
${RSH} -n ${HOST} sqlplus $USER
@$ACID_DIR/isolation/a_query $OKEY >> $TXN2FILE
else
sqlplus $USER @$ACID_DIR/isolation/a_query $OKEY >>
$TXN2FILE
fi
```

```
echo "-----" >>
$TXN2FILE
```

```
wait
echo "-----" >>
$TXN1FILE
```

```
cat $TXN1FILE $TXN2FILE >> $ISOFILE
```

```
/bin/rm -rf $TXN1FILE $TXN2FILE $KEYFILE
```

### iso2.sh

```
#!/bin/ksh
#
# $Header: iso2.sh 04-aug-99.09:19:54 mpoess Exp $
#
# iso2.sh
#
# Copyright (c) Oracle Corporation 1999. All Rights
Reserved.
#
# NAME
# iso2.sh - <one-line expansion of the name>
#
# DESCRIPTION
# Usage: iso2.sh [-u user/password] [-n remote_node] -h
# Options: See usage below
# NOTES
# For a cross node isolation test, assume the local node is
# one of the participating nodes. The other node can be
# specified by the -n option.
# You need to set the environment variable
TPCD_KIT_DIR
#
# MODIFIED (MM/DD/YY)
# mpoess 08/04/99 - Creation
```

```
# mpoess 08/04/99 - Creation
#
#
#
```

```
=====
=====+
# May need to change the following:
```

```
. $KIT_DIR/env
```

```
RSH=ssh
```

```
OH=$ORACLE_HOME
# ACID_DIR=$TPCD_KIT_DIR/audit is set in env
OUT_DIR=$ACID_OUT
```

```
DURA_DIR=$ACID_DIR/dura
```

```
TXN1FILE=$OUT_DIR/txn1$.out
TXN2FILE=$OUT_DIR/txn2$.out
KEYFILE=$OUT_DIR/key$.out
ISOFILE=$OUT_DIR/iso2
```

```
USER=$DATABASE_USER
PROG=atranspl
```

```
/bin/rm -rf $TXN1FILE $TXN2FILE $KEYFILE
```

```
trap "/bin/rm -rf $TXN1FILE $TXN2FILE $KEYFILE; exit
1" 1 2 3 15
```

```
usage() {
```

```
echo ""
echo "Usage: $0 [-u user/passwd] [-n remote_node] -h"
echo ""
exit 1;
}
```

```
set -- `getopt "u:n:h" "$@"` || usage
```

```
while :
do
case "$1" in
-u) shift; USER=$1;;
-n) shift; HOST="$1";;
-h) usage; exit 0;;
--) break;;
esac
shift;
done
```

```
# generate key files
```

```
randkey 1 0.1 u"$USER" > $KEYFILE
```

```
OKEY=`cat $KEYFILE | awk '{print $1}'`
echo "o_key is "$OKEY
```

## Appendix C

```
# before the ACID transaction, let's run a ACID query to
record the
# initial state of lineitem

echo "Running ACID query BEFORE the start of Isolation
Test 1" >> $TXN2FILE
echo "`date`" >> $TXN2FILE
echo "" >> $TXN2FILE
sqlplus "$USER" @$ACID_DIR/isolation/a_query $OKEY
>> $TXN2FILE
echo "" >> $TXN2FILE
echo "-----" >>
$TXN2FILE

sleep 1

# start ACID transaction, Sleep for 30 second before
ROLLBACK

$PROG 1 1 0 0 i$KEYFILE u$USER s30 >> $TXN1FILE &

# let's sleep 15 seconds before starting ACID query

sleep 15

# start ACID query with the same OKEY

echo "Running ACID query 15 seconds AFTER the start of
ACID transaction" \
>> $TXN2FILE
echo "`date`" >> $TXN2FILE
if [ "$HOST" != "" ]
then
echo "Starting ACID query on node $HOST" >> $TXN2FILE
${RSH} -n ${HOST} sqlplus "$USER"
@$ACID_DIR/isolation/a_query $OKEY >> $TXN2FILE
else
sqlplus $USER @$ACID_DIR/isolation/a_query $OKEY >>
$TXN2FILE
fi

echo "-----" >>
$TXN2FILE
wait
echo "-----" >>
$TXN1FILE

cat $TXN1FILE $TXN2FILE >> $ISOFILE

/bin/rm -rf $TXN1FILE $TXN2FILE $KEYFILE

iso3.sh
#!/bin/ksh
#
# $Header: iso3.sh 04-aug-99.09:20:35 mpoess Exp $
#
# iso3.sh
#
```

```
# Copyright (c) Oracle Corporation 1999. All Rights
Reserved.
#
# NAME
# iso3.sh - <one-line expansion of the name>
#
# DESCRIPTION
# Usage: iso3.sh [-u user/password] [-n remote_node] -h
# Options: See usage below
# NOTES
# For a cross node isolation test, assume the local node is
# one of the participating nodes. The other node can be
# specified by the -n option.
# We need to make sure the remote node has access to
the
# file system on the local node. Otherwise, we need to
rcp
# the keyfile to the remote system.
# You need to set the environment variable
TPCD_KIT_DIR
#
# MODIFIED (MM/DD/YY)
# mpoess 08/04/99 - Creation
# mpoess 08/04/99 - Creation
#

.$KIT_DIR/env

# May need to change the following:
RSH=ssh

OH=$ORACLE_HOME
#ACID_DIR=$TPCD_KIT_DIR/audit is set in env
OUT_DIR=$ACID_OUT

DURA_DIR=$ACID_DIR/dura

TXN1FILE=$OUT_DIR/txn1$.out
TXN2FILE=$OUT_DIR/txn2$.out
KEYFILE=$OUT_DIR/key$.out
ISOFILE=$OUT_DIR/iso3

USER=$DATABASE_USER
PROG=atranspl

/bin/rm -rf $TXN1FILE $TXN2FILE $KEYFILE

trap "/bin/rm -rf $TXN1FILE $TXN2FILE $KEYFILE; exit
1" 1 2 3 15

usage() {

echo ""
echo "Usage: $0 [-u user/passwd] [-n remote_node] -h"
echo ""
exit 1;
}

set -- `getopt "u:n:h" "$@"` || usage
```

## Appendix C

```

while :
do
  case "$1" in
    -u) shift; USER=$1;;
    -n) shift; HOST="$1";;
    -h) usage; exit 0;;
    --) break;;
    esac
  shift
done

# generate key files

randkey 1 0.1 u"$USER" > $KEYFILE
scp $KEYFILE ${HOST}.$KEYFILE

sleep 1

# start ACID transaction, Sleep for 30 second before
COMMIT

$PROG 1 2 1 0 i$KEYFILE u$USER s30 b0 >> $TXN1FILE
&

# let's sleep 15 seconds before starting second ACID
transaction

sleep 15

# start another ACID transaction with the same LKEY and
OKEY
# but different DELTA

# Do not sleep before COMMIT so that we can see TXN2 has
waited.

if [ "$HOST" != "" ]
then
echo "Starting TXN2 on node $HOST" >> $TXN2FILE
${RSH} -n ${HOST} $PROG 2 2 1 1 i$KEYFILE u$USER
s1 b1 >> $TXN2FILE &
else
$PROG 2 2 1 1 i$KEYFILE u$USER s1 b1 >> $TXN2FILE
&
fi

wait
echo "-----" >>
$TXN2FILE
echo "-----" >>
$TXN1FILE

cat $TXN1FILE $TXN2FILE >> $ISOFILE

/bin/rm -rf $TXN1FILE $TXN2FILE $KEYFILE

iso4.sh

```

```

#!/bin/ksh
#
# $Header: iso4.sh 04-aug-99.09:21:12 mpoess Exp $
#
# iso4.sh
#
# Copyright (c) Oracle Corporation 1999. All Rights
Reserved.
#
# NAME
#   iso4.sh - <one-line expansion of the name>
#
# DESCRIPTION
#   Usage: iso4.sh [-u user/password] [-n remote_node] -h
#   Options: See usage below
# NOTES
#   For a cross node isolation test, assume the local node is
#   one of the participating nodes. The other node can be
#   specified by the -n option.
#   We need to make sure the remote node has access to the
#   file system on the local node. Otherwise, we need to rcp
#   the keyfile to the remote system.
#   You need to set the environment variable
TPCD_KIT_DIR
#
# MODIFIED (MM/DD/YY)
# mpoess 08/04/99 - Creation
# mpoess 08/04/99 - Creation
#

. $KIT_DIR/env

# May need to change the following:
RSH=ssh

OH=$ORACLE_HOME
# ACID_DIR=$TPCD_KIT_DIR/audit is set in env
OUT_DIR=$ACID_OUT

DURA_DIR=$ACID_DIR/dura

TXN1FILE=$OUT_DIR/txn1$$.$out
TXN2FILE=$OUT_DIR/txn2$$.$out
KEYFILE=$OUT_DIR/key$$.$out
ISOFILE=$OUT_DIR/iso4

USER=$DATABASE_USER
PROG=atranspl

/bin/rm -rf $TXN1FILE $TXN2FILE $KEYFILE

trap "/bin/rm -rf $TXN1FILE $TXN2FILE $KEYFILE; exit
1" 1 2 3 15

usage() {

  echo ""
  echo "Usage: $0 [-u user/passwd] [-n remote_node] -h"
  echo ""

```

## Appendix C

```
exit 1;
}

set -- `getopt "u:n:h" "$@"` || usage

while :
do
  case "$1" in
    -u) shift; USER=$1;;
    -n) shift; HOST="$1";;
    -h) usage; exit 0;;
    --) break;;
    esac
  shift
done

# generate key files

randkey 1 0.1 u"$USER"> $KEYFILE
scp $KEYFILE ${HOST}:$KEYFILE

sleep 1

# start ACID transaction, Sleep for 30 second before
ROLLBACK

$PROG 1 2 0 0 i$KEYFILE u$USER s30 b0 >> $TXN1FILE
&

# let's sleep 15 seconds before starting second ACID
transaction

sleep 15

# start another ACID transaction with the same LKEY and
OKEY
# but different DELTA

# Do not sleep before COMMIT so that we can see TXN2 has
waited.

if [ "$HOST" != "" ]
then
echo "Starting TXN2 on node $HOST" >> $TXN2FILE
${RSH} -n ${HOST} $PROG 2 2 1 1 i$KEYFILE u$USER
s1 b1 >> $TXN2FILE &
else
$PROG 2 2 1 1 i$KEYFILE u$USER s1 b1 >> $TXN2FILE
&
fi

wait
echo "-----" >>
$TXN2FILE
echo "-----" >>
$TXN1FILE

cat $TXN1FILE $TXN2FILE >> $ISOFILE
```

```
/bin/rm -rf $TXN1FILE $TXN2FILE $KEYFILE
```

### iso5.sh

```
#!/bin/ksh
#
# $Header: iso5.sh 04-aug-99.09:21:45 mpoess Exp $
#
# iso5.sh
#
# Copyright (c) Oracle Corporation 1999. All Rights
Reserved.
#
# NAME
# iso5.sh - <one-line expansion of the name>
#
# DESCRIPTION
# Usage: iso5.sh [-u user/password] [-n remote_node] -h
# Options: See usage below
# NOTES
# For a cross node isolation test, assume the local node is
# one of the participating nodes. The other node can be
# specified by the -n option.
# You need to set the environment variable
TPCD_KIT_DIR
#
# MODIFIED (MM/DD/YY)
# mpoess 08/04/99 - Creation
# mpoess 08/04/99 - Creation
#

.$KIT_DIR/env

# May need to change the following:
RSH=ssh

OH=$ORACLE_HOME
# ACID_DIR=$TPCD_KIT_DIR/audit is set in env
OUT_DIR=$ACID_OUT
DURA_DIR=$ACID_DIR/dura

TXN1FILE=$OUT_DIR/txn1$$.out
TXN2FILE=$OUT_DIR/txn2$$.out
KEYFILE=$OUT_DIR/key$$.out
ISOFILE=$OUT_DIR/iso5

USER=$DATABASE_USER
PROG=atranspl

/bin/rm -rf $TXN1FILE $TXN2FILE $KEYFILE

trap "/bin/rm -rf $TXN1FILE $TXN2FILE $KEYFILE; exit
1" 1 2 3 15

usage() {
  echo ""
  echo "Usage: $0 [-u user/passwd] [-n remote_node] -h"
  echo ""
```

## Appendix C

```
exit 1;
}

set -- `getopt "u:n:h" "$@" || usage

while :
do
  case "$1" in
    -u) shift; USER=$1;;
    -n) shift; HOST="$1";;
    -h) usage; exit 0;;
    --) break;;
    esac
  shift;
done

# generate key files

randkey 1 0.1 u"$USER"> $KEYFILE
scp $KEYFILE ${HOST}:$KEYFILE

OKEY=`cat $KEYFILE | awk '{print $1}'`
echo "o_key is "$OKEY

# before the ACID transaction, let's run a ACID query to
record the
# initial state of lineitem

echo "Running ACID query BEFORE the start of Isolation
Test 5" >> $TXN1FILE
echo "`date`" >> $TXN1FILE
echo "" >> $TXN1FILE
sqlplus $USER @$ACID_DIR/isolation/a_query $OKEY >>
$TXN1FILE
echo "" >> $TXN1FILE
echo "-----" >>
$TXN1FILE

sleep 1

# start ACID transaction, Sleep for 60 second before
COMMIT

$PROG 1 1 1 0 i$KEYFILE u$USER s60 >> $TXN1FILE &

# let's sleep 5 seconds before starting PARTSUPP query

sleep 5

# First generate PS_PARTKEY and PS_SUPPKEY

PSKEY=`randpsup 1`

echo "Running PARTSUPP query 5 seconds AFTER the start
of ACID Transaction" \
>> $TXN2FILE
echo "`date`" >> $TXN2FILE
```

```
echo "PS_PARTKEY and PS_SUPPKEY are: $PSKEY" >>
$TXN2FILE

if [ "$HOST" != "" ]
then
echo "Starting PARTSUPP query on node $HOST" >>
$TXN2FILE
${RSH} -n ${HOST} sqlplus $USER
@$ACID_DIR/isolation/a_query2 ${PSKEY} >>
$TXN2FILE &
else
sqlplus $USER @$ACID_DIR/isolation/a_query2 ${PSKEY}
>> $TXN2FILE &
fi

wait

echo "-----" >>
$TXN2FILE
echo "-----" >>
$TXN1FILE

cat $TXN1FILE $TXN2FILE >> $ISOFILE

/bin/rm -rf $TXN1FILE $TXN2FILE $KEYFILE

iso6.sh
#!/bin/ksh
#
# $Header: iso6.sh 04-aug-99.09:22:12 mpoess Exp $
#
# iso6.sh
#
# Copyright (c) Oracle Corporation 1999. All Rights
Reserved.
#
# NAME
# iso6.sh - <one-line expansion of the name>
#
# DESCRIPTION
# Usage: iso6.sh [-u user/password] [-n remote_node] -h
# Options: See usage below
# NOTES
# For a cross node isolation test, assume the local node is
# one of the participating nodes. The other node can be
# specified by the -n option.
# We need to make sure the remote node has access to the
# file system on the local node. Otherwise, we need to rcp
# the keyfile to the remote system.
# You need to set the environment variable
TPCD_KIT_DIR
#
# MODIFIED (MM/DD/YY)
# mpoess 08/04/99 - Creation
# mpoess 08/04/99 - Creation
#
.$KIT_DIR/env
```

## Appendix C

```
# May need to change the following:
RSH=ssh

OH=/private/tpcd
# ACID_DIR=$TPCD_KIT_DIR/audit is set in env
OUT_DIR=$ACID_OUT

DURA_DIR=$ACID_DIR/dura

TXN1FILE=$OUT_DIR/txn1$.out
TXN2FILE=$OUT_DIR/txn2$.out
TXN3FILE=$OUT_DIR/txn3$.out
KEYFILE=$OUT_DIR/key$.out
ISOFILE=$OUT_DIR/iso6

USER=$DATABASE_USER
PROG=atranspl

/bin/rm -rf $TXN1FILE $TXN2FILE $TXN3FILE
$KEYFILE

trap "/bin/rm -rf $TXN1FILE $TXN2FILE $TXN3FILE
$KEYFILE; exit 1" 1 2 3 15

usage() {
    echo ""
    echo "Usage: $0 [-u user/passwd] [-n remote_node] -h"
    echo ""
    exit 1;
}

set -- `getopt "u:n:h" "$@"` || usage

while :
do
    case "$1" in
    -u) shift; USER=$1;;
    -n) shift; HOST="$1";;
    -h) usage; exit 0;;
    --) break;;
    esac
    shift;
done

# generate key files

randkey 1 0.1 u"$USER" > $KEYFILE
scp $KEYFILE ${HOST}.$KEYFILE

OKEY=`cat $KEYFILE | awk '{print $1}'`
echo "o_key is "$OKEY

# before the any transaction, let's run a ACID query to record
the
# initial state of lineitem

echo "Running ACID query BEFORE the start of Isolation
Test 6" >> $TXN2FILE
echo "`date`" >> $TXN2FILE
echo "" >> $TXN2FILE
sqlplus $USER @$ACID_DIR/isolation/a_query $OKEY >>
$TXN2FILE
echo "" >> $TXN2FILE
echo "-----" >>
$TXN2FILE

sleep 1

# start Query 1, use 0 as the delta

echo "Running Query 17b at `date`" >> $TXN1FILE
sqlplus $USER @q1 >> $TXN1FILE &

# sleep 2 seconds before starting ACID transaction

sleep 2

# start ACID transaction, COMMIT after one second

echo "Starting AICD transaction at `date`" >> $TXN2FILE

if [ "$HOST" != "" ]
then
echo "Starting ACID transaction on node $HOST" >>
$TXN2FILE
${RSH} -n ${HOST} $PROG 1 1 1 0 i$KEYFILE u$USER
s1 >> $TXN2FILE &
else
$PROG 1 1 1 0 i$KEYFILE u$USER s1 >> $TXN2FILE &
fi

# start Query 17

sleep 2

echo "Running 2nd Query 17b at `date`" >> $TXN3FILE
sqlplus $USER @q1 >> $TXN3FILE &
# wait for everyone to finish

wait

echo "-----" >>
$TXN3FILE
echo "-----" >>
$TXN2FILE
echo "-----" >>
$TXN1FILE

cat $TXN1FILE $TXN2FILE $TXN3FILE >> $ISOFILE

/bin/rm -rf $TXN1FILE $TXN2FILE $TXN3FILE
$KEYFILE

nohup.out
+ [ /mnt/sdb2/home/oracle/frame = ]
```

## Appendix C

```
+ [ 1 -lt 1 ]
+ . /mnt/sdb2/home/oracle/frame/env
+ [ /mnt/sdb2/home/oracle/frame = ]
+ export INTERNAL_USER=/ as sysdba
+ [ = ]
+ export FRAME_USER=tpch/tpch
+ export
FRAME_VARIABLES=/mnt/sdb2/home/oracle/frame/variables/30g.var
+ export SCALE_FACTOR=300
+ uname -n
+ sed s/\.*//g
+ export HOST_NAME=PE6600A
+ export PRIMARY_NODE=PE6600A
+ export SECONDARY_NODES=PE6600B
+ export REMOTE_FRAME_PATH=/frame
+ export PLATFORM=Linux
+ export MY_NODE_NAME=PE6600A
+ export PAR_HINT=8
+ export VX_GRP=vglvm
+ export VXTOGR_ARGS=-s lineitem=line[1-84]:orders=orders[1-84]:customer=cust[1-4]:part=:parts:partsupp=psupp[1-8]:supplier:supp:system=sys:undo=undo:i_c_custkey=custkey:i_1_orderkey=lokey[1-8]:i_o_orderkey=okekey[1-4]:ps_partkey_suppley=psuppind[1-2]:temp=temp[1-65]:lpkey=temp[66-79]:log=temp[81-82]:other=*
+ export ITOGR_ARGS=-frw
+ export VMTOGR_ARGS=-c4
+ export SARTOGR_ARGS=-c4
+ export VMTOGR_OPS_ARGS=-c4
+ export SARTOGR_OPS_ARGS=-c4
+ export STARTSTAT_OPTIONS=-vm -sm -be -ne
+ export FRAME_VPLAN=yes
+ export IOSTAT_TYPE=thr tps
+ export IOSTAT_DISKS=sda sdb sdc sde sdf sdg sdi sdj sdk sdm sdn sdo sdq sdr sds sdu sdv sdw sdy sdz sdaa sdac sdad sdae
+ export VXSTAT_TYPE=thr tps
+ export DISPLAY_GRAPHS=no
+ export EXPLAIN_ALL=q1 q2 q3 q4 q5 q6 q7 q8 q9 q10 q11 q12 q13 q14 q15 q15_with q16 q17 q18 q19 q20 q21 q22
+ export RUN_ALL=q14 q2 q9 q20 q6 q17 q18 q8 q21 q13 q3 q22 q16 q4 q11 q15 q15a q1 q10 q19 q5 q7 q12
+ export
INIT_ORA=/mnt/sdb2/home/oracle/10g/DB/dbs/init_run.ora
+ export RUN_PATH=. /mnt/sdb2/home/oracle/kit/myqueries /mnt/sdb2/home/oracle/kit/dell_qry
+ TITLE=
+ LOGS=
+ RNAME=
+ ARGUMENTS=
+ [ q6 != ]
+ [ q6 = -d ]
+ [ q6 = -t ]
+ [ q6 = -a ]
+ [ q6 = -l ]
+ [ q6 = -ns ]
+ [ != ]
+ RNAME=q6
+ QFNAME=q6
+ export QFNAME
+ shift
+ [ != ]
+ find_query q6
+ QUERY=/mnt/sdb2/home/oracle/kit/dell_qry/q6.sql
+ [ /mnt/sdb2/home/oracle/kit/dell_qry/q6.sql = ]
+ echo /mnt/sdb2/home/oracle/kit/dell_qry/q6.sql
+ sed -e s/\.*.sql$/sql/g
+ EXT=sql
+ cat /mnt/sdb2/home/oracle/frame/runid
+ RUNID=3975
+ [ RUNID = ]
+ let NEW_RUNID=RUNID+1
+ echo 3976
+ > /mnt/sdb2/home/oracle/frame/runid
+ echo
+ sed -n -e s/^(.*)\.[a-z]*^/1.env/gp
+ ENV_FILE=
+ [ -f ]
+
STAT_DIR=/mnt/sdb2/home/oracle/frame/stats/stat_q6_3975
+ mkdir -p /mnt/sdb2/home/oracle/frame/stats/stat_q6_3975
+ basename /mnt/sdb2/home/oracle/frame/stats/stat_q6_3975
+ LABEL=q6
+ date +%D %H:%M
+ ssh PE6600B mkdir -p /mnt/sdb2/home/oracle//frame/stats/stat_q6_3975
+ DATE=09/08/04 18:00
+
LOGFILE=/mnt/sdb2/home/oracle/frame/stats/stat_q6_3975/q6_3975.log
+ [ /mnt/sdb2/home/oracle/10g/DB/dbs/init_run.ora != ]
+ [ -f /mnt/sdb2/home/oracle/10g/DB/dbs/init_run.ora ]
+ /mnt/sdb2/home/oracle/frame/bin/ora_label
+ >
/mnt/sdb2/home/oracle/frame/stats/stat_q6_3975/ora_label.txt
+ /mnt/sdb2/home/oracle/frame/bin/ora_params
+ >
/mnt/sdb2/home/oracle/frame/stats/stat_q6_3975/ora_params.txt
+ [ sql = sql ]
+ STARTSTAT_OPTIONS=-vm -sm -be -ne -pl
+ [ != ]
+ /mnt/sdb2/home/oracle/frame/bin/startstat q6_3975 5
/mnt/sdb2/home/oracle/frame/stats/stat_q6_3975 -vm -sm -be -ne -pl
start statistics on PE6600B
ssh PE6600B -n /mnt/sdb2/home/oracle//frame/bin/startstat q6_3975 5 /mnt/sdb2/home/oracle/frame/stats/stat_q6_3975 -vm -sm -be -ne -pl
PID for all processes to kill
/mnt/sdb2/home/oracle/frame/stats/stat_q6_3975 5 0 5711 0 5715 0 1 0 0 0 1 0 0 0 0 5714 5712 5713
+ [ sql = sql ]
+ Q=/tmp/runq_query5671.sql
+ cat /mnt/sdb2/home/oracle/kit/dell_qry/q6.sql
+ sed -e s/select/\^* 5671 \^* select/g
```

## Appendix C

```
+ sed -e s/SELECT/SELECT \\\* 5671 \\\*\\/ /g
+ > /tmp/runq_query5671.sql
+ execute_query q6_3975 /tmp/runq_query5671.sql
+ >
/mnt/sdb2/home/oracle/frame/stats/stat_q6_3975/q6_3975.log
+ 2>&1
+ rm -f runq_query5671.sql
+ /mnt/sdb2/home/oracle/frame/bin/stopstat q6_3975
+ . /mnt/sdb2/home/oracle/frame/env
+ [ /mnt/sdb2/home/oracle/frame = ]
+ export INTERNAL_USER=/ as sysdba
+ [ = ]
+ export FRAME_USER=tpch/tpch
+ export
FRAME_VARIABLES=/mnt/sdb2/home/oracle/frame/variabl
es/30g.var
+ export SCALE_FACTOR=300
+ uname -n
+ sed s/\\.*///g
+ export HOST_NAME=PE6600B
+ export PRIMARY_NODE=PE6600A
+ export SECONDARY_NODES=PE6600B
+ export REMOTE_FRAME_PATH=/frame
+ export PLATFORM=Linux
+ export MY_NODE_NAME=PE6600B
+ export PAR_HINT=8
+ export VX_GRP=vglvm
+ export VXTOGR_ARGS=-s lineitem=line[1-
84]:orders=orders[1-84]:customer=cust[1-
4]:part=:parts:partsupp=psupp[1-
8]:supplier:supp:system=sys:undo=undo:i_c_custkey=custkey
:i_1_orderkey=lokey[1-8]:i_o_orderkey=okey[1-
4]:ps_partkey_suppley=psuppind[1-2]:temp=temp[1-
65]:lpkey=temp[66-79]:log=log[81-82]:other=*
+ export IOTOGR_ARGS=-frw
+ export VMTOGR_ARGS=-c4
+ export SARTOGR_ARGS=-c4
+ export VMTOGR_OPS_ARGS=-c4
+ export SARTOGR_OPS_ARGS=-c4
+ export STARTSTAT_OPTIONS=-vm -sm -be -ne
+ export FRAME_VPLAN=yes
+ export IOSTAT_TYPE=thr tps
+ export IOSTAT_DISKS=sda sdb sdc sde sdf sdg sdi sdj sdk
sdm sdn sdo sdq sdr sds sdu sdv sdw sdy sdz sdaa sdac sdad
sdae
+ export VXSTAT_TYPE=thr tps
+ export DISPLAY_GRAPHS=no
+ export EXPLAIN_ALL=q1 q2 q3 q4 q5 q6 q7 q8 q9 q10
q11 q12 q13 q14 q15 q15_with q16 q17 q18 q19 q20 q21 q22
+ export RUN_ALL=q14 q2 q9 q6 q17 q8 q21 q13 q3 q22
q16 q4 q11 q15 q1 q10 q19 q5 q7 q12
+ export
INIT_ORA=/mnt/sdb2/home/oracle/10g/DB/dbs/init_run.ora
+ export RUN_PATH=. /mnt/sdb2/home/oracle/kit/myqueries
/mnt/sdb2/home/oracle/kit/dell_qry
+ [ /mnt/sdb2/home/oracle/frame = ]
+ [ sda sdb sdc sde sdf sdg sdi sdj sdk sdm sdn sdo sdq sdr sds
sdu sdv sdw sdy sdz sdaa sdac sdad sdae = ]
+ [ 8 -lt 2 ]
+ FULL_LABEL=q6_3975
+ shift
+ SAMPLE=5
+ shift
+ BESTAT=0
+ SQLMON=0
+ SQLSA=0
+ VXSTAT=0
+ IOSTAT=0
+ VMSTAT=0
+ PLSTAT=0
+ SARSTAT=0
+ SAR2STAT=0
+ SCIDSTAT=0
+ NESTAT=0
+ TITLE_GRAPH=
+ [ /mnt/sdb2/home/oracle/frame/stats/stat_q6_3975 = ]
+ echo /mnt/sdb2/home/oracle/frame/stats/stat_q6_3975
+ sed -e s/\\(-).*/^1/g
+ SGN=/mnt/sdb2/home/oracle/frame/stats/stat_q6_3975
+ [ /mnt/sdb2/home/oracle/frame/stats/stat_q6_3975 != - ]
+ DIR=/mnt/sdb2/home/oracle/frame/stats/stat_q6_3975
+ shift
+ [ -vm != ]
+ [ -vm = -vx ]
+ [ -vm = -ne ]
+ [ -vm = -pl ]
+ [ -vm = -t ]
+ [ -vm = -vm ]
+ VMSTAT=1
+ shift
+ continue
+ [ -sm != ]
+ [ -sm = -vx ]
+ [ -sm = -ne ]
+ [ -sm = -pl ]
+ [ -sm = -t ]
+ [ -sm = -vm ]
+ [ -sm = -sr ]
+ [ -sm = -mp ]
+ [ -sm = -io ]
+ [ -sm = -be ]
+ [ -sm = -sm ]
+ SQLMON=1
+ shift
+ continue
+ [ -be != ]
+ [ -be = -vx ]
+ [ -be = -ne ]
+ [ -be = -pl ]
+ [ -be = -t ]
+ [ -be = -vm ]
+ [ -be = -sr ]
+ [ -be = -mp ]
+ [ -be = -io ]
+ [ -be = -be ]
+ BESTAT=1
+ shift
+ continue
```



## Appendix C

```
+ [ -ne != ]
+ [ -ne = -vx ]
+ [ -ne = -ne ]
+ NESTAT=1
+ shift
+ continue
+ [ -pl != ]
+ [ -pl = -vx ]
+ [ -pl = -ne ]
+ [ -pl = -pl ]
+ PLSTAT=1
+ shift
+ continue
+ [ != ]
+ HOST_LABEL=PE6600B.
+ [ PE6600B != PE6600A ]
+ basename /mnt/sdb2/home/oracle/frame/stats/stat_q6_3975
+ DIR=/mnt/sdb2/home/oracle/frame/stats/stat_q6_3975
+ [ ! -d /mnt/sdb2/home/oracle/frame/stats/stat_q6_3975 ]
+
SCID_OUT=/mnt/sdb2/home/oracle/frame/stats/stat_q6_3975/scid.q6_3975.PE6600B.out
+
SCID_OUT1=/mnt/sdb2/home/oracle/frame/stats/stat_q6_3975/scid.q6_3975.PE6600B.out1
+
IOSTAT_OUT=/mnt/sdb2/home/oracle/frame/stats/stat_q6_3975/iostat.q6_3975.PE6600B.out
+
VMSTAT_OUT=/mnt/sdb2/home/oracle/frame/stats/stat_q6_3975/vmstat.q6_3975.PE6600B.out
+
NESTAT_OUT=/mnt/sdb2/home/oracle/frame/stats/stat_q6_3975/nestat.q6_3975.PE6600B.out
+
SARSTAT_OUT=/mnt/sdb2/home/oracle/frame/stats/stat_q6_3975/sar.q6_3975.PE6600B.bin
+
SAR2STAT_OUT=/mnt/sdb2/home/oracle/frame/stats/stat_q6_3975/sar2.q6_3975.PE6600B.bin
+
VSARSTAT_OUT=/mnt/sdb2/home/oracle/frame/stats/stat_q6_3975/network.q6_3975.PE6600B.text
+
CLICSTAT_OUT=/mnt/sdb2/home/oracle/frame/stats/stat_q6_3975/clic.q6_3975.PE6600B.text
+
UDPSTAT_OUT=/mnt/sdb2/home/oracle/frame/stats/stat_q6_3975/udp.q6_3975.PE6600B.text
+ PIDVX=0
+ PIDSA=0
+ PIDVM=0
+ PIDIO=0
+ PIDNE=0
+ PIDMON=0
+ PIDSC=0
+ PIDSC1=0
+ PIDSAR=0
+ PIDSAR2=0
+ PIDVSAR=0
+ PIDCLIC=0
+ PIDUDP=0
+
DATE_1=/mnt/sdb2/home/oracle/frame/stats/stat_q6_3975/statdate.q6_3975
+ [ 1 -eq 10 ]
+ [ 1 -eq 1 ]
+ bsp.sh
+ > /tmp/snap1
+ [ 0 -eq 1 ]
+ [ 0 -eq 1 ]
+ [ 1 -eq 1 ]
+ vmstat 5
+ >
/mnt/sdb2/home/oracle/frame/stats/stat_q6_3975/vmstat.q6_3975.PE6600B.out
+ PIDVM=2860
+ [ 1 -eq 1 ]
+ getnet.pl 5
+ >
/mnt/sdb2/home/oracle/frame/stats/stat_q6_3975/nestat.q6_3975.PE6600B.out
+ PIDNE=2861
+ [ 0 -eq 1 ]
+ [ 0 -eq 1 ]
+ [ 1 -eq 1 ]
+ sqlmon q6_3975
/mnt/sdb2/home/oracle/frame/stats/stat_q6_3975
+ PIDMON=2862
+ [ 0 -eq 1 ]
+ [ 0 -eq 1 ]
+ date
+ >
/mnt/sdb2/home/oracle/frame/stats/stat_q6_3975/startdate.q6_3975
PID for all processes to kill
/mnt/sdb2/home/oracle/frame/stats/stat_q6_3975 5 0 2860 0 2862 0 1 0 0 0 1 0 0 0 0 2861
+ echo PID for all processes to kill
/mnt/sdb2/home/oracle/frame/stats/stat_q6_3975 5 0 2860 0 2862 0 1 0 0 0 1 0 0 0 0 2861
+ echo /mnt/sdb2/home/oracle/frame/stats/stat_q6_3975 5 0 2860 0 2862 0 1 0 0 0 1 0 0 0 0 2861
+ > /tmp/q6_3975.statenv
/mnt/sdb2/home/oracle/frame/bin/ora[1815]: ||: unexpected `||'
+ . /mnt/sdb2/home/oracle/frame/env
+ [ /mnt/sdb2/home/oracle/frame = ]
+ export INTERNAL_USER=/ as sysdba
+ [ = ]
+ export FRAME_USER=tpch/tpch
+ export
FRAME_VARIABLES=/mnt/sdb2/home/oracle/frame/variables/30g.var
+ export SCALE_FACTOR=300
+ uname -n
+ sed s/\.*//g
+ export HOST_NAME=PE6600B
+ export PRIMARY_NODE=PE6600A
```

## Appendix C

```
+ export SECONDARY_NODES=PE6600B
+ export REMOTE_FRAME_PATH=/frame
+ export PLATFORM=Linux
+ export MY_NODE_NAME=PE6600B
+ export PAR_HINT=8
+ export VX_GRP=vglvm
+ export VXTOGR_ARGS=-s lineitem=line[1-
84]:orders=orders[1-84]:customer=cust[1-
4]:part=:parts:partsupp=psupp[1-
8]:supplier:supp:system=sys:undo=undo:i_c_custkey=custkey
:i_1_orderkey=lokey[1-8]:i_o_orderkey=okey[1-
4]:ps_partkey_suppley=psuppind[1-2]:temp=temp[1-
65]:lpkey=temp[66-79]:log=temp[81-82]:other=*
+ export ITOGR_ARGS=-frw
+ export VMTOGR_ARGS=-c4
+ export SARTOGR_ARGS=-c4
+ export VMTOGR_OPS_ARGS=-c4
+ export SARTOGR_OPS_ARGS=-c4
+ export STARTSTAT_OPTIONS=-vm -sm -be -ne
+ export FRAME_VPLAN=yes
+ export IOSTAT_TYPE=thr tps
+ export IOSTAT_DISKS=sda sdb sdc sde sdf sdg sdi sdj sdk
sdm sdn sdo sdq sdr sds sdu sdv sdw sdy sdz sdaa sdac sdad
sdae
+ export VXSTAT_TYPE=thr tps
+ export DISPLAY_GRAPHS=no
+ export EXPLAIN_ALL=q1 q2 q3 q4 q5 q6 q7 q8 q9 q10
q11 q12 q13 q14 q15 q15_with q16 q17 q18 q19 q20 q21 q22
+ export RUN_ALL=q14 q2 q9 q6 q17 q8 q21 q13 q3 q22
q16 q4 q11 q15 q1 q10 q19 q5 q7 q12
+ export
INIT_ORA=/mnt/sdb2/home/oracle/10g/DB/dbs/init_run.ora
+ export RUN_PATH=. /mnt/sdb2/home/oracle/kit/myqueries
/mnt/sdb2/home/oracle/kit/dell_qry
+ [ /mnt/sdb2/home/oracle/frame = ]
+ MAX_NBPOINTS=100
+ [ -c4 = ]
+ [ -c4 = ]
+ [ -frw = ]
+ [ Linux = SunOS ]
+ [ Linux = HP ]
+ [ Linux = Linux ]
+ cat /proc/cpuinfo
+ grep processor
+ wc -l
+ NUM_PROC= 8
+ VMTOGR_ARGS=-c4 -c 8
+ SARTOGR_ARGS=-c4 -c 8
+ date
+ DATE_2=Wed Sep 8 18:00:40 CDT 2004
+ FULL_LABEL=q6_3975
+ [ ! -f /tmp/q6_3975.statenv ]
+ cat /tmp/q6_3975.statenv
+ set /mnt/sdb2/home/oracle//frame/stats/stat_q6_3975 5 0
2860 0 2862 0 1 0 0 0 1 0 0 0 0 2861
+ DIR=/mnt/sdb2/home/oracle//frame/stats/stat_q6_3975
+ SAMPLE=5
+ PIDIO=0
+ PIDVM=2860
+ PIDVX=0
+ PIDMON=2862
+ PIDSA=0
+ BESTAT=1
+ PIDSC=0
+ PIDSC1=0
+ PIDSAR=0
+ PLSTAT=1
+ PIDSAR2=0
+ PIDVSAR=0
+ PIDCLIC=0
+ PIDUDP=0
+ PIDNE=2861
+
TITLE_GRAPH=/mnt/sdb2/home/oracle//frame/stats/stat_q6_
3975 5 0 2860 0 2862 0 1 0 0 0 1 0 0 0 0 2861
+ basename /mnt/sdb2/home/oracle//frame/stats/stat_q6_3975
+ BASEDIR=stat_q6_3975
+ DISP=0
+ [ no = yes ]
+ HOST_LABEL=PE6600B.
+
VMSTAT_OUT_PREFIX=/mnt/sdb2/home/oracle//frame/stat
s/stat_q6_3975/vmstat.q6_3975.PE6600B.
+
SARSTAT_OUT_PREFIX=/mnt/sdb2/home/oracle//frame/sta
ts/stat_q6_3975/sar.q6_3975.PE6600B.
+
SAR2STAT_OUT_PREFIX=/mnt/sdb2/home/oracle//frame/st
ats/stat_q6_3975/sar2.q6_3975.PE6600B.
+
VSARSTAT_OUT_PREFIX=/mnt/sdb2/home/oracle//frame/s
tats/stat_q6_3975/network.q6_3975.PE6600B.
+
CLICSTAT_OUT_PREFIX=/mnt/sdb2/home/oracle//frame/st
ats/stat_q6_3975/clic.q6_3975.PE6600B.
+
SPRSTAT_OUT_PREFIX=/mnt/sdb2/home/oracle//frame/stat
s/stat_q6_3975/spr.q6_3975.PE6600B.
+
VXSTAT_OUT=/mnt/sdb2/home/oracle//frame/stats/stat_q6_
3975/vxstat_vglvm_q6_3975.PE6600B.out
+
IOSTAT_AGGR=/mnt/sdb2/home/oracle//frame/stats/stat_q6
_3975/iostat.q6_3975*out
+
VMSTAT_AGGR=/mnt/sdb2/home/oracle//frame/stats/stat_q
6_3975/vmstat.q6_3975.*.out
+
SARSTAT_AGGR=/mnt/sdb2/home/oracle//frame/stats/stat_q
6_3975/sar.q6_3975.*.out
+
SAR2STAT_AGGR=/mnt/sdb2/home/oracle//frame/stats/stat_
q6_3975/sar2.q6_3975.*.out
+
VXSTAT_AGGR=/mnt/sdb2/home/oracle//frame/stats/stat_q6
_3975/vxstat_vglvm_q6_3975*out
+ [ 2860 -ne 0 ]
+ kill -9 2860
```

## Appendix C

```
+ [ 2861 -ne 0 ]
+ kill -9 2861
+ [ 0 -ne 0 ]
+ [ 0 -ne 0 ]
+ [ 0 -ne 0 ]
+ [ 0 -ne 0 ]
+ [ 0 -ne 0 ]
+ [ 0 -ne 0 ]
+ [ 0 -ne 0 ]
+ [ 1 -eq 1 ]
+ do_spreport
+ [ PE6600B = PE6600A ]
+ [ PE6600B = PE6600A ]
+ [ 2862 -ne 0 ]
+ kill -9 2862
+ cat
/mnt/sdb2/home/oracle//frame/stats/stat_q6_3975/startdate.q6
_3975
+ DATE_1=Wed Sep 8 18:00:40 CDT 2004
+ diffd Wed Sep 8 18:00:40 CDT 2004 Wed Sep 8 18:00:40
CDT 2004
+ let NBSAMPLE=DIFSEC/SAMPLE
+ [ 0 -gt 100 ]
+ GROUPBY=1
+ [ 1 -lt 1 ]
+ sqlplus -s /NOLOG
+ << !
+ grep ###
+ sed -e s/###\([0-9]*\).*\1/g
+ > /tmp/stopout2874
+ cat /tmp/stopout2874
+ VERSION=10
+ let VERSION=VERSION+0
+ rm -f /tmp/stopout2874
+ [ 10 -ge 9 -a 1 -eq 1 ]
+ sqlplus -s /NOLOG
+ << !
+ grep ###
+ > /tmp/stopout2874
+ cat /tmp/stopout2874
+ read a
+ cat /tmp/stopout2874
+ read a
+ xplan
+ >
/mnt/sdb2/home/oracle//frame/stats/stat_q6_3975/.q6_3975.pl
an
+ rm -f /tmp/stopout2874
+ [ 0 -ne 0 ]
+ [ 0 -ne 0 ]
+ [ 2861 -ne 0 ]
+ [ PE6600B = PE6600A ]
+ [ 2860 -ne 0 ]
+ TITLE=q6_3975
+ [ /mnt/sdb2/home/oracle//frame/stats/stat_q6_3975 5 0 2860
0 2862 0 1 0 0 0 1 0 0 0 0 2861 = ]
+ TIT=/mnt/sdb2/home/oracle//frame/stats/stat_q6_3975 5 0
2860 0 2862 0 1 0 0 0 1 0 0 0 0 2861
+ vmtogr -p Linux -g 1 -t CPU statistics
(/mnt/sdb2/home/oracle//frame/stats/stat_q6_3975 5 0 2860 0
2862 0 1 0 0 0 1 0 0 0 0 2861_PE6600B) -c4 -c 8 -i 5 -o
/mnt/sdb2/home/oracle//frame/stats/stat_q6_3975/vmstat.q6_3
975.PE6600B.graph
/mnt/sdb2/home/oracle//frame/stats/stat_q6_3975/vmstat.q6_3
975.PE6600B.out
/mnt/sdb2/home/oracle//frame/bin/stopstat[567]: vmtogr: not
found
+ vmtocpgr.pl
/mnt/sdb2/home/oracle//frame/stats/stat_q6_3975/vmstat.q6_3
975.PE6600B.out 5
output file =
/mnt/sdb2/home/oracle//frame/stats/stat_q6_3975/vmstat.q6_3
975.PE6600B.graph
+ vmtoiogr.pl
/mnt/sdb2/home/oracle//frame/stats/stat_q6_3975/vmstat.q6_3
975.PE6600B.out 5
output file =
/mnt/sdb2/home/oracle//frame/stats/stat_q6_3975/iostat.q6_39
75.PE6600B_thr.graph
+ [ PE6600B = PE6600A ]
+ [ 0 -eq 1 ]
+ [ 0 -ne 0 ]
+ [ 0 -ne 0 ]
+ [ 0 -ne 0 ]
+ [ 2862 -ne 0 ]
+ [ PE6600B ]
+
SQLMON_OUT_PREFIX=/mnt/sdb2/home/oracle//frame/stat
s/stat_q6_3975/sql_q6_3975.PE6600B.
+ [ PE6600B = PE6600A ]
+ mmtogr -o
/mnt/sdb2/home/oracle//frame/stats/stat_q6_3975/sql_q6_397
5.PE6600B.graph -t q6_3975_PE6600B
/mnt/sdb2/home/oracle//frame/stats/stat_q6_3975/sql_q6_397
5.PE6600B.mm
/mnt/sdb2/home/oracle//frame/bin/stopstat[669]: mmtogr: No
such file or directory
+ [ 0 -eq 1 ]
+ slvs_on_what
/mnt/sdb2/home/oracle//frame/stats/stat_q6_3975/startdate.q6
_3975
+ >>
/mnt/sdb2/home/oracle//frame/stats/stat_q6_3975/slaves_q6_3
975.PE6600B.graph
+ top_events
/mnt/sdb2/home/oracle//frame/stats/stat_q6_3975/startdate.q6
_3975
+ >>
/mnt/sdb2/home/oracle//frame/stats/stat_q6_3975/top_events_
q6_3975.PE6600B.graph
+ top_events_time
/mnt/sdb2/home/oracle//frame/stats/stat_q6_3975/startdate.q6
_3975
+ >>
/mnt/sdb2/home/oracle//frame/stats/stat_q6_3975/top_events_
time_q6_3975.PE6600B.graph
```

## Appendix C

```
+ try_top_events
/mnt/sdb2/home/oracle//frame/stats/stat_q6_3975/startdate.q6
_3975
+ >>
/mnt/sdb2/home/oracle//frame/stats/stat_q6_3975/top_events_
sqlplus_q6_3975.PE6600B.graph
+ [ PE6600B = PE6600A ]
+ rm -f /tmp/q6_3975.statenv
+ ls
/mnt/sdb2/home/oracle//frame/stats/stat_q6_3975/nestat.q6_3
975.PE6600B.out
/mnt/sdb2/home/oracle//frame/stats/stat_q6_3975/vmstat.q6_3
975.PE6600B.out
+ > /dev/null
+ 2>&1
+ [ 0 -eq 0 -a PE6600A = PE6600B ]
mv: cannot stat `/tmp/sp_report.lst': No such file or directory
scp: /tmp/sp_report.lst: No such file or directory
rm: cannot remove `/tmp/sp_report.lst': No such file or
directory
/mnt/sdb2/home/oracle/frame/bin/stopstat[348]: select ':
unexpected ``
+ export STAT_DIR
+ cat
/mnt/sdb2/home/oracle/frame/stats/stat_q6_3975/q6_3975.log
+ sed -n -e s/Execution Time for Query: \(.*\)1/gp
+ ETIME=00s
+ echo Execution time for q6 (runid 3975): 00s
Execution time for q6 (runid 3975): 00s
+ echo Execution time for q6 (runid 3975): 00s
+ > /mnt/sdb2/home/oracle/frame/stats/stat_q6_3975/times.log
+ COMMENT=
+ [ != ]
+ [ != ]
+ echo 09/08/04 18:00 \t 3975 \t q6 \t (time=00s)
+ >> /mnt/sdb2/home/oracle/frame/lbook
```

### randkey.c

```
/* Copyright (c) 2001, 2002, Oracle Corporation. All rights
reserved. */
```

```
/*
```

```
NAME
randkey.c - <one-line expansion of the name>
```

#### DESCRIPTION

```
Generate random keys for ACID transactions:
O_ORDERKEY unique random (1..SF*150000*4) and
only
first 8 keys out of every 32 are populated.
and
L_ORDERKEY based on Clause 3.1.6.2
DELTA random (1..100)
*/
```

```
#include <stdio.h>
#include <stdlib.h>
#include <math.h>
```

```
#include "atranspl.h"
```

```
#define ORDERCNT 150000.0
```

```
/* MK_SPARSE adopted from dss.h */
```

```
#define MK_SPARSE(key, seq) \
((((key>>3)<<2)|(seq & 0x0003))<<3)|(key & 0x0007))
```

```
void sql_error();
void usage();
void ACIDinit();
long atol();
void srand48();
long lrand48();
```

```
/* Not really used here, but retained it for future purposes. */
```

```
typedef struct aciddef {
    long okey;
    long lkey;
    int delta;
} adef;
```

```
long l_key = 0;
long o_key = 0;
char lname[UNAME_LEN];
char *passwd;
```

```
/* OCI handles */
```

```
OCIEnv *tpcenv;
OCIServer *tpcsrv;
OCIError *errhp;
OCISvcCtx *tpcsvc;
OCISession *tpcusr;
OCISmt *curi;
```

```
OCIBind *l_key_bp;
OCIBind *o_key_bp;
```

```
sword status = OCI_SUCCESS; /* OCI return value */
```

```
char sqlstmt[1024];
```

```
void ACIDexit() {
    OCILogoff(tpcsvc, errhp);
    OCIHfree(tpcenv, OCI_HTYPE_STMT);
    OCIHfree(tpcsvc, OCI_HTYPE_SVCCTX);
    OCIHfree(tpcsrv, OCI_HTYPE_SERVER);
    OCIHfree(tpcusr, OCI_HTYPE_SESSION);
}
```

```
/* type: 0 if environment handle is passed, 1 if error handle is
passwd */
```

```
void sql_error(errhp, status, type)
```

## Appendix C

```

OCIError *errhp;
sword status;
sword type;
{
char msg[2048];
sb4 errcode;
ub4 msglen;
int i,j;

switch(status) {
case OCI_SUCCESS_WITH_INFO:
fprintf(stderr, "Error: Statement returned with info.\n");
if (type)
(void) OCIErrorGet(errhp,1,NULL,(sb4 *) &errcode,(text
*)msg,
2048,OCI_HTYPE_ERROR);
else
(void) OCIErrorGet(errhp,1,NULL,(sb4 *) &errcode,(text
*)msg,
2048,OCI_HTYPE_ENV);
fprintf(stderr,"%s\n",msg);
break;
case OCI_ERROR:
fprintf(stderr, "Error: OCI call error.\n");
if (type)
(void) OCIErrorGet(errhp,1,NULL,(sb4 *) &errcode,(text
*)msg,
2048,OCI_HTYPE_ERROR);
else
(void) OCIErrorGet(errhp,1,NULL,(sb4 *) &errcode,(text
*)msg,
2048,OCI_HTYPE_ENV);
fprintf(stderr,"%s\n",msg);
break;
case OCI_INVALID_HANDLE:
fprintf(stderr, "Error: Invalid Handle.\n");
if (type)
(void) OCIErrorGet(errhp,1,NULL,(sb4 *) &errcode,(text
*)msg,
2048,OCI_HTYPE_ERROR);
else
(void) OCIErrorGet(errhp,1,NULL,(sb4 *) &errcode,(text
*)msg,
2048,OCI_HTYPE_ENV);
fprintf(stderr,"%s\n",msg);
break;
}
/* Rollback just in case */

(void) OCITransRollback(tpcsvc,errhp,OCI_DEFAULT);

fprintf(stderr, "Exiting Oracle...\n");
fflush(stderr);

ACIDexit();

exit(1);
}

```

```

main(argc, argv)
int argc;
char **argv;
{

long count;
long i;
double sf; /* need to accomodate sf 0.1 */
double random;
double ordcnt;
adef *res;

if ((argc < 3) || (argc > 4)) {
usage();
exit(-1);
}

strcpy((char *) lname, "tpcd/tpcd");

count = atol(argv[1]);
sf = atof(argv[2]);

argc -= 2;
argv += 2;

while (--argc) {
++argv;
switch(argv[0][0]) {
case 'u':
strncpy((char *) lname, ++(argv[0]), UNAME_LEN);
if (strchr((char *) lname, '/') == NULL) {
usage();
exit(-1);
}
break;
default:
fprintf(stderr, "Unknown argument %s\n", argv[0]);
usage();
break;
}
}

ACIDinit();

/* initialize array for random numbers */

res = (adef *) malloc(count*sizeof(adef));
ordcnt = (double) ORDERCNT * (double) sf;

for (i=0; i<count; i++) {

/* The algorithm: */
/* Assumes drand's output is 'unique', first get a number
within */
/* the range of [0..sf*ORDERCNT) and then maps the
different */
/* ranges to generate the real output. */
}
}

```

## Appendix C

```

random = floor(drand48() * (double) ordcnt) + 1;
res[i].okey = o_key = (long) MK_SPARSE((long) random,
0);
res[i].delta = (long) floor(drand48() * 100) + 1;

/* Obtain l_key from l_key query */

OCIsexec(tpcsvc,curi,errhp,1);

/* l_key is the highest l_linenumber available. We need to
pick */
/* at random a number between 1..l_key. */

res[i].lkey = (lrand48() % l_key) + 1;

printf("%ld %ld %d\n", res[i].okey, res[i].lkey, res[i].delta);
}

ACIDexit();
free(res);

}

void usage() {

    fprintf(stderr, "Usage: randkey <number of random keys to
generate> <SF> u<user/password>\n");
    fprintf(stderr, "\n");
}

void ACIDinit()
{

/* run random seed */

srand48(getpid());

/* Connect to ORACLE. Program will call sql_error()
if an error occurs in connecting to the default database. */

(void) OCIInitialize(OCI_DEFAULT,(dvoid *)0,0,0,0);
if((status=OCIEnvInit((OCIEnv
**)&tpcenv,OCI_DEFAULT,0,(dvoid **)0)) !=
OCI_SUCCESS)
    sql_error(tpcenv, status, 0);

OCIhalloc(tpcenv,&errhp,OCI_HTYPE_ERROR);
OCIhalloc(tpcenv,&curi,OCI_HTYPE_STMT);
OCIhalloc(tpcenv,&tpcsvc,OCI_HTYPE_SVCCTX);
OCIhalloc(tpcenv,&tpcsrv,OCI_HTYPE_SERVER);
OCIhalloc(tpcenv,&tpcusr,OCI_HTYPE_SESSION);

/* get username and password */

passwd = strchr(lname, '/');
*passwd = '\0';
passwd++;

```

```

if ((status=OCIServerAttach(tpcsrv,errhp,(text
*)0,0,OCI_DEFAULT))!=OCI_SUCCESS)
    sql_error(errhp,status,1);

OCIaset(tpcsvc,OCI_HTYPE_SVCCTX,tpcsrv,0,OCI_ATTR
_SERVER,errhp);

OCIaset(tpcusr,OCI_HTYPE_SESSION,lname,strlen(lname),
OCI_ATTR_USERNAME,
errhp);

OCIaset(tpcusr,OCI_HTYPE_SESSION,passwd,strlen(passw
d),OCI_ATTR_PASSWORD,
errhp);

if ((status = OCISessionBegin(tpcsvc, errhp, tpcusr,
OCI_CRED_RDBMS,
OCI_DEFAULT)) != OCI_SUCCESS)
    sql_error(errhp,status,1);

OCIaset(tpcsvc,OCI_HTYPE_SVCCTX,tpcusr,0,OCI_ATTR
_SESSION,errhp);

/* Open and Parse cursor for query to choose determine
l_key. */
/* Binds l_key to :l_key. */

sprintf((char *) sqlstmt,SQLTXT1);
OCIStmtPrepare(curi,errhp,(text *)sqlstmt,strlen((char
*)sqlstmt),
OCI_NTV_SYNTAX,OCI_DEFAULT);

OCIbname(curi,l_key_bp,errhp,":l_key",ADR(l_key),SIZ(l
_key),SQLT_INT);

OCIbname(curi,o_key_bp,errhp,":o_key",ADR(o_key),SIZ(
o_key),SQLT_INT);
}

```

### randpsup.c

/\* Copyright (c) 2001, 2002, Oracle Corporation. All rights reserved. \*/

/\*

NAME

randpsup.c - <one-line expansion of the name>

DESCRIPTION

Generate random keys for ACID PARTSUPP transactions:  
(Clause 4.2.3)

PS\_PARTKEY random within [SF\*200000]

and

PS\_SUPPKEY = (PS\_PARTKEY + (i \* ((S/4) +  
(int)(PS\_PARTKEY - 1)  
/S))) % S + 1

## Appendix C

where  $i$  random within  $[0..3]$  and  $S = SF * 10000$

MODIFIED

```
mpoess 10/23/02 - mpoess_update_from_visa
mpoess 01/04/01 - Creation

*/

#include <stdio.h>
#include <stdlib.h>
#include <math.h>

#define PS_PER_SF 200000.0
#define S_PER_SF 10000.0
#define SUPP_PER_PART 4

/* borrowed from build.c in the dbgen distribution */

#define PART_SUPP_BRIDGE(tgt, p, s) \
{ \
    long tot_scnt = (long) (S_PER_SF * sf); \
    tgt = (p + s * (tot_scnt / SUPP_PER_PART + \
        (long) ((p - 1) / tot_scnt))) % tot_scnt + 1; \
}

void usage();
double atof();
void srand48();
long lrand48();

main(argc, argv)
    int argc;
    char **argv;
{

    double sf = 0.1;        /* scale factor */
    long supp;             /* the i-th supplier */
    long pkey;             /* partkey */
    long maxpkey;          /* highest partkey */
    long ps_skey;          /* ps_supkey */

    if (argc < 2) {
        usage();
        exit(-1);
    }

    /* seed the random number generator */

    srand48(getpid());

    sf = atof(argv[1]);
    maxpkey = (long) (sf * PS_PER_SF);
    supp = lrand48() % 4;
    pkey = lrand48() % maxpkey + 1;

    PART_SUPP_BRIDGE(ps_skey, pkey, supp);

    fprintf(stdout, "%ld %ld", pkey, ps_skey);
```

```
    exit(0);
}

void usage()
{
    fprintf(stderr, "Usage: randpsup <SF>\n\n");
}
```

**run\_acid.sh**

```
#!/bin/ksh
#
# $Header: run_acid.sh 08-aug-99.15:30:10 mpoess Exp $
#
# run_acid.sh
#
# Copyright (c) Oracle Corporation 1999. All Rights
# Reserved.
#
# NAME
#   run_acid.sh - <one-line expansion of the name>
#
# DESCRIPTION
#   Usage: run_acid.sh [-n iter] [-s stream] [-p prog] [-i
#   infile]
#
#               [-o outfile] [-d durafile] [-u usr/pswd]
#               [-t trigger] [-f scale factor] -h
#
#   Options: See usage below
#
#   MODIFIED (MM/DD/YY)
#   mpoess 08/08/99 - Creation
#   mpoess 08/08/99 - Creation
#

. $KIT_DIR/env

OH=$ORACLE_HOME
ACID_DIR=$ACID_DIR
OUT_DIR=$ACID_OUT

usage() {

    echo ""
    echo "Usage: $0 [-n iter] [-s stream] [-p prog] [-i infile] [-o
    outfile]"
    echo "           [-d durafile] [-u usr/pswd] -h"
    echo ""
    echo "-n iter    : number of iterations, default is 100"
    echo "-s stream  : number of streams, default is 2"
    echo "-p prog    : program to run, default is atranspl.ott"
    echo "-i infile  : input file prefix, suffix by process number
    within a"
    echo "           stream and run ID, default is ./acid_in"
    echo "-o outfile : output file prefix, similar to input file"
    echo "           default is ./out/acid_out"
```

## Appendix C

```
echo "-d durafile : durability file prefix, used for durability
tests"
echo "      default is ./dura/acid_dura"
echo "-u usr/pswd : user/password combo for database
access, default is tpch/tpch"
echo "-t trigger : trigger time between process starts, default
is 1 second"
echo "-h      : print this usage summary"
exit 1;
}

ITER=600
STEM=${NUM_STREAMS}
let STEM="$STEM + 1" # add one for the update stream
SF=1
PROG=atranspl
IN=${ACID_DIR}/acid_in
DURA_DIR=${ACID_OUT}/dura
OUT=${DURA_DIR}/drate
DURA=${DURA_DIR}/dura
KEY=${DURA_DIR}/key$$_
echo "$$" > ${DURA_DIR}/shellpid
USER=tpch/tpch
TRIG=1
HCNT=duraentb

set -- `getopt "n:s:p:i:o:d:u:ht:f:" "$@"` || usage

# get all the options

while :
do
  case "$1" in
    -n) shift; ITER=$1;;
    -s) shift; STEM=$1;;
    -p) shift; PROG=$1;;
    -i) shift; IN=$1;;
    -o) shift; OUT=$1;;
    -d) shift; DURA=$1;;
    -u) shift; USER=$1;;
    -h) usage; exit 0;;
    -t) shift; TRIG=$1;;
    -f) shift; SF=$1;;
    --) break;;
    esac
  shift;
done

echo "Starting ACID run..."

i=0
T=`expr $STEM \* $TRIG + 6`

# Get history count before the run

sqlplus $USER @cnt_hist > $DURA_DIR/$HCNT 2>&1

while [ $i -lt $STEM ]
do
  randkey $ITER ${SF} u${USER} > ${KEY}${i} &
  i=`expr $i + 1`
done

wait
# perform the consistency

i=0
while [ $i -lt $STEM ]
do
  for j in `head -10 ${KEY}${i} | awk '{printf "%d ", $1}'`
  do
    sqlplus tpch/tpch @consist $j >> $DURA_DIR/duraconsb
  done
  i=`expr $i + 1`
done

echo "Starting Transaction Counting Program"
count_tx.sh $STEM 100 $DURA_DIR &

i=0
while [ $i -lt $STEM ]
do
  $PROG $i $STEM 1 0 i${KEY}${i} o${OUT}${i}
  d${DURA}${i} u$USER s1 &
  T=`expr $T - $TRIG`
  i=`expr $i + 1`
done

wait

echo "ACID run completed"

sample.sh
#!/bin/ksh
#
# $Header: sample.sh 08-aug-99.17:10:00 mpoess Exp $
#
# sample.sh
#
# Copyright (c) Oracle Corporation 1999. All Rights
Reserved.
#
# NAME
#   sample.sh - <one-line expansion of the name>
#
# DESCRIPTION
#   <short description of component this file
declares/defines>
#
# NOTES
#   <other useful comments, qualifications, etc.>
#
# MODIFIED (MM/DD/YY)
#   mpoess   08/08/99 - Creation
#   mpoess   08/08/99 - Creation
```



## Appendix C

```
#
# $1 durability output file
. $KIT_DIR/env

cat $1 | grep o_key | awk '{printf "%d\n", $2}' | head -106 >
/tmp/okey$$
cat $1 | grep l_key | awk '{printf "%d\n", $2}' | head -106 >
/tmp/lkey$$

paste /tmp/okey$$ /tmp/lkey$$ > /tmp/keys$$
tail -6 /tmp/keys$$ > /tmp/6keys$$

echo "Keys chosen are:"
cat /tmp/6keys$$

i=1
while [ $i -le 6 ]
do
j=`cat /tmp/6keys$$ | tail -${i} | head -1`
sqlplus tpch/tpch @sample $j
i=`expr $i + 1`
done
#/bin/rm -f /tmp/*key*
```

### sample.sql

```
Rem
Rem $Header: sample.sql 08-aug-99.17:10:34 mpoess Exp $
Rem
Rem sample.sql
Rem
Rem Copyright (c) Oracle Corporation 1999. All Rights
Reserved.
Rem
Rem NAME
Rem sample.sql - <one-line expansion of the name>
Rem
Rem DESCRIPTION
Rem <short description of component this file
declares/defines>
Rem
Rem NOTES
Rem <other useful comments, qualifications, etc.>
Rem
Rem MODIFIED (MM/DD/YY)
Rem mpoess 08/08/99 - Creation
Rem mpoess 08/08/99 - Created
Rem
alter session set nls_date_format = 'YYYY-MM-DD
HH:MI:SS';
select * from history where h_o_key = &&1 and
h_l_key = &&2;
exit;
```

## Appendix D: Query text and Output

## Appendix D

Begin Execution at Mon Sep 6 12:37:22 2004

### 1.log

Begin Execution at Mon Sep 6 12:37:14 2004

```
-- using default substitutions
select
l_returnflag,
l_linestatus,
sum(l_quantity) as sum_qty,
sum(l_extendedprice) as sum_base_price,
sum(l_extendedprice * (1 - l_discount)) as sum_disc_price,
sum(l_extendedprice * (1 - l_discount) * (1 + l_tax)) as
sum_charge,
avg(l_quantity) as avg_qty,
avg(l_extendedprice) as avg_price,
avg(l_discount) as avg_disc,
count(*) as count_order
from
lineitem
where
l_shipdate <= to_date ('1998-12-01','YYYY-MM-DD') - 90
group by
l_returnflag,
l_linestatus
order by
l_returnflag,
l_linestatus
```

L_RETURNFLAG	L_LINESTATUS	SUM_QTY	SUM_BASE_PRICE	SUM_DISC_PRICE	SUM_CHARGE	AVG_QTY	AVG_PRICE	AVG_DISC	COUNT_ORDER
A	F	37734107.00	56586554400.73			25.52	53758257134.87	55909065222.83	38273.13
									1478493.00
N	F	991417.00	1487504710.38			25.52	1413082168.05	1469649223.19	38284.47
									38854.00
N	O	74476040.00	111701729697.74			25.50	106118230307.61	110367043872.50	38249.12
									2920374.00
R	F	37719753.00	56568041380.90			25.51	53741292684.60	55889619119.83	38250.85
									1478870.00

4 rows processed.  
Query Processed in 7.70 seconds.  
Ended Executing this Stream at Mon Sep 6 12:37:22 2004

Stream Started at 1094492234.86  
Stream Ended at 1094492242.56  
Stream Processed in 7.70 seconds

SQL statements processed: 1

### 2.log

-- using default substitutions

```
select * from (
select
s_acctbal,
s_name,
n_name,
p_partkey,
p_mfgr,
s_address,
s_phone,
s_comment
from
part,
supplier,
partsupp,
nation,
region
where
p_partkey = ps_partkey
and s_suppkey = ps_suppkey
and p_size = 15
and p_type like '%BRASS'
and s_nationkey = n_nationkey
and n_regionkey = r_regionkey
and r_name = 'EUROPE'
and ps_supplycost = (
select
min(ps_supplycost)
from
partsupp,
supplier,
nation,
region
where
p_partkey = ps_partkey
and s_suppkey = ps_suppkey
and s_nationkey = n_nationkey
and n_regionkey = r_regionkey
and r_name = 'EUROPE'
)
)
order by
s_acctbal desc,
n_name,
s_name,
p_partkey
)
where rownum <= 100
```

S_ACCTBAL	S_NAME	N_NAME
P_PARTKEY	P_MFGR	
S_ADDRESS		S_PHONE
S_COMMENT		

## Appendix D

9938.53	Supplier#000005359	UNITED	4841.00	Manufacturer#4	
KINGDOM			JOIK7C1,7xrEZSSOw		32-399-414-5385
185358.00	Manufacturer#4		final accounts haggle. bold accounts are furiously dugouts.		
QKuHYh,vZGiwu2FWEJoLDx04		33-429-790-	furiously silent asymptotes are slyly		
6131			9817.10	Supplier#000002352	RUSSIA
blithely silent pinto beans are furiously. slyly final deposits			124815.00	Manufacturer#2	
acros			4LfoHUZjgjEbAKw TgdKcgOc4D4uCYw		32-551-831-
9937.84	Supplier#000005969	ROMANIA	1437		
108438.00	Manufacturer#1		blithely pending packages across the ironic accounts grow		
ANDENSOSmk,miq23Xfb5RWt6dvUcvt6Qa		29-520-	slyly after the furiously		
692-3537			9817.10	Supplier#000002352	RUSSIA
carefully slow deposits use furiously. slyly ironic platelets			152351.00	Manufacturer#3	
above the ironic			4LfoHUZjgjEbAKw TgdKcgOc4D4uCYw		32-551-831-
9936.22	Supplier#000005250	UNITED	1437		
KINGDOM			blithely pending packages across the ironic accounts grow		
249.00	Manufacturer#4		slyly after the furiously		
B3rq0xbSEim4Mpy2RH J		33-320-228-2957	9739.86	Supplier#000003384	FRANCE
blithely special packages are. stealthily express deposits			138357.00	Manufacturer#2	
across the closely final instructi			o,Z3v4POifevE k9U1b 6J1ucX,I		16-494-913-5925
9923.77	Supplier#000002324	GERMANY	slyly ironic theodolites hag		
29821.00	Manufacturer#4		9721.95	Supplier#000008757	UNITED
y3OD9UywSTOk		17-779-299-1839	KINGDOM		
quickly express packages breach quiet pinto beans. requ			156241.00	Manufacturer#3	
9871.22	Supplier#000006373	GERMANY	Atg6GnM4dT2		33-821-407-2995
43868.00	Manufacturer#5		ironic, even dolphins above the furiously ironic foxes sleep		
J8fcXWsTqM		17-813-485-8637	slyly around the caref		
never silent deposits integrate furiously blit			9681.33	Supplier#000008406	RUSSIA
9870.78	Supplier#000001286	GERMANY	78405.00	Manufacturer#1	
81285.00	Manufacturer#2		,qUuXcftUl		32-139-873-8571
YKA,E2fjiVd7eUrzp2Ef8j1QxGo2DFnosATEH		17-516-	furiously even deposits affix thinly special theodolites. furiou		
924-4574			9643.55	Supplier#000005148	ROMANIA
final theodolites cajole slyly special,			107617.00	Manufacturer#1	
9870.78	Supplier#000001286	GERMANY	kT4ciVFslx9z4s79p Js825		29-252-617-4850
181285.00	Manufacturer#4		doggedly even ideas boost furiously against the furiously		
YKA,E2fjiVd7eUrzp2Ef8j1QxGo2DFnosATEH		17-516-	express		
924-4574			9624.82	Supplier#000001816	FRANCE
final theodolites cajole slyly special,			34306.00	Manufacturer#3	
9852.52	Supplier#000008973	RUSSIA	e7vab91vLJPWxxZnewmnDBpDmxYHrb		16-392-237-
18972.00	Manufacturer#2		6726		
t5L67YdBYH6o,Vz24jpDyQ9		32-188-594-7038	blithely regular accounts cajole furiously. regular		
quickly regular instructions wake-- carefully unusual braids			9624.78	Supplier#000009658	ROMANIA
into the expres			189657.00	Manufacturer#1	
9847.83	Supplier#000008097	RUSSIA	oE9uBgEfSS4opIcepXyAYM,x		29-748-876-2014
130557.00	Manufacturer#2		regular deposits haggle. furiously express asympto		
xMe97bpE69NzdwLoX		32-375-640-3593	9612.94	Supplier#000003228	ROMANIA
slyly regular dependencies sleep slyly furiously express dep			120715.00	Manufacturer#2	
9847.57	Supplier#000006345	FRANCE	KDdpNKN3cWu7ZSrbdq7AfSLxx,qWB		29-325-784-
86344.00	Manufacturer#1		8187		
VSt3rzk3qG698u6ld8HhOByvrTcSTSvQIDQDag		16-886-	carefully pending accounts serve. furiously close deposits		
766-7945			boost slyly. q		
silent pinto beans should have to snooze carefully along the					
final reques			----- <rows truncated>		
9847.57	Supplier#000006345	FRANCE	-----		
173827.00	Manufacturer#2				
VSt3rzk3qG698u6ld8HhOByvrTcSTSvQIDQDag		16-886-			
766-7945					
silent pinto beans should have to snooze carefully along the			100 rows processed.		
final reques			Query Processed in 0.24 seconds.		
9836.93	Supplier#000007342	RUSSIA			

## Appendix D

Ended Executing this Stream at Mon Sep 6 12:37:22 2004

Stream Started at 1094492242.62  
Stream Ended at 1094492242.86  
Stream Processed in 0.24 seconds

SQL statements processed: 1

### 3.log

Begin Execution at Mon Sep 6 12:37:22 2004

-- using default substitutions

```
select * from (
select
l_orderkey,
sum(l_extendedprice * (1 - l_discount)) as revenue,
o_orderdate,
o_shippriority
from
customer,
orders,
lineitem
where
c_mktsegment = 'BUILDING'
and c_custkey = o_custkey
and l_orderkey = o_orderkey
and o_orderdate < to_date('1995-03-15', 'YYYY-MM-DD')
and l_shipdate > to_date('1995-03-15', 'YYYY-MM-DD')
group by
l_orderkey,
o_orderdate,
o_shippriority
order by
revenue desc,
o_orderdate)
where rownum <= 10
```

L_ORDERKEY	REVENUE	O_ORDERDATE	O_SHIPRIORITY
2456423.00	406181.01	1995-03-05	0.00
3459808.00	405838.70	1995-03-04	0.00
492164.00	390324.06	1995-02-19	0.00
1188320.00	384537.94	1995-03-09	0.00
2435712.00	378673.06	1995-02-26	0.00
4878020.00	378376.80	1995-03-12	0.00
5521732.00	375153.92	1995-03-13	0.00
2628192.00	373133.31	1995-02-22	0.00
993600.00	371407.46	1995-03-05	0.00
2300070.00	367371.15	1995-03-13	0.00

10 rows processed.  
Query Processed in 1.79 seconds.

Ended Executing this Stream at Mon Sep 6 12:37:24 2004

Stream Started at 1094492242.93  
Stream Ended at 1094492244.71  
Stream Processed in 1.79 seconds

SQL statements processed: 1

### 4.log

Begin Execution at Mon Sep 6 12:37:24 2004

-- using default substitutions

```
select
o_orderpriority,
count(*) as order_count
from
orders
where
o_orderdate >= to_date('1993-07-01', 'YYYY-MM-DD')
and o_orderdate < add_months(to_date('1993-07-01',
'YYYY-MM-DD'),3)
and exists (
select
*
from
lineitem
where
l_orderkey = o_orderkey
and l_commitdate < l_receiptdate
)
group by
o_orderpriority
order by
o_orderpriority

O_ORDERPRIORITY ORDER_COUNT
1-URGENT 10594.00
2-HIGH 10476.00
```

## Appendix D

3-MEDIUM 10410.00  
4-NOT SPECIFIED 10556.00  
5-LOW 10487.00

CHINA 53724494.26  
INDIA 52035512.00  
JAPAN 45410175.70

5 rows processed.  
Query Processed in 2.07 seconds.

5 rows processed.  
Query Processed in 2.63 seconds.

Ended Executing this Stream at Mon Sep 6 12:37:26 2004

Ended Executing this Stream at Mon Sep 6 12:37:29 2004

Stream Started at 1094492244.77  
Stream Ended at 1094492246.84  
Stream Processed in 2.07 seconds

Stream Started at 1094492246.90  
Stream Ended at 1094492249.53  
Stream Processed in 2.63 seconds

SQL statements processed: 1

SQL statements processed: 1

### 5.log

Begin Execution at Mon Sep 6 12:37:26 2004

### 6.log

Begin Execution at Mon Sep 6 12:37:29 2004

-- using default substitutions

-- using default substitutions

```
select
n_name,
sum(l_extendedprice * (1 - l_discount)) as revenue
from
customer,
orders,
lineitem,
supplier,
nation,
region
where
c_custkey = o_custkey
and l_orderkey = o_orderkey
and l_suppkey = s_suppkey
and c_nationkey = s_nationkey
and s_nationkey = n_nationkey
and n_regionkey = r_regionkey
and r_name = 'ASIA'
and o_orderdate >= to_date('1994-01-01', 'YYYY-MM-DD')
and o_orderdate < add_months(to_date('1994-01-01',
'YYYY-MM-DD'), 12)
group by
n_name
order by
revenue desc
```

```
select
sum(l_extendedprice * l_discount) as revenue
from
lineitem
where
l_shipdate >= to_date('1994-01-01', 'YYYY-MM-DD')
and l_shipdate < add_months(to_date('1994-01-01', 'YYYY-
MM-DD'), 12)
and l_discount between .06 - 0.01 and .06 + 0.01
and l_quantity < 24
```

REVENUE  
123141078.23

1 row processed.  
Query Processed in 0.25 seconds.

Ended Executing this Stream at Mon Sep 6 12:37:29 2004

Stream Started at 1094492249.59  
Stream Ended at 1094492249.84  
Stream Processed in 0.25 seconds

SQL statements processed: 1

N_NAME	REVENUE
INDONESIA	55502041.17
VIETNAM	55295087.00

## Appendix D

### 7.log

Begin Execution at Mon Sep 6 12:37:29 2004

-- using default substitutions

```
select
supp_nation,
cust_nation,
l_year,
sum(volume) as revenue
from
(
select
n1.n_name as supp_nation,
n2.n_name as cust_nation,
to_number (to_char
(l_shipdate,'yyyy')) as l_year,
l_extendedprice * (1 - l_discount) as volume
from
supplier,
lineitem,
orders,
customer,
nation n1,
nation n2
where
s_suppkey = l_suppkey
and o_orderkey = l_orderkey
and c_custkey = o_custkey
and s_nationkey = n1.n_nationkey
and c_nationkey = n2.n_nationkey
and (
(n1.n_name = 'FRANCE' and n2.n_name = 'GERMANY')
or (n1.n_name = 'GERMANY' and n2.n_name = 'FRANCE')
)
and l_shipdate between to_date( '1995-01-01', 'YYYY-MM-DD') and to_date( '1996-12-31', 'YYYY-MM-DD')
) shipping
group by
supp_nation,
cust_nation,
l_year
order by
supp_nation,
cust_nation,
l_year
```

SUPP_NATION	CUST_NATION	L_YEAR
REVENUE		
FRANCE	GERMANY	1995.00
54639732.73		
FRANCE	GERMANY	1996.00
54633083.31		
GERMANY	FRANCE	1995.00
52531746.67		

GERMANY  
52520549.02

FRANCE

1996.00

4 rows processed.  
Query Processed in 2.07 seconds.

Ended Executing this Stream at Mon Sep 6 12:37:31 2004

Stream Started at 1094492249.90  
Stream Ended at 1094492251.96  
Stream Processed in 2.07 seconds

SQL statements processed: 1

### 8.log

Begin Execution at Mon Sep 6 12:37:32 2004

-- using default substitutions

```
select
o_year,
sum(case when nation='BRAZIL' then volume else 0 end )/
sum(volume)
as mkt_share
from
(
select
to_number (to_char (o_orderdate, 'yyyy')) as o_year,
l_extendedprice * (1 - l_discount) as volume,
n2.n_name as nation
from
part,
supplier,
lineitem,
orders,
customer,
nation n1,
nation n2,
region
where
p_partkey = l_partkey
and s_suppkey = l_suppkey
and l_orderkey = o_orderkey
and o_custkey = c_custkey
and c_nationkey = n1.n_nationkey
and n1.n_regionkey = r_regionkey
and r_name = 'AMERICA'
and s_nationkey = n2.n_nationkey
```

## Appendix D

```

and o_orderdate between to_date ('1995-01-01', 'YYYY-MM-DD') and to_date ('1996-12-31', 'YYYY-MM-DD')
and p_type = 'ECONOMY ANODIZED STEEL'
) all_nations
group by
o_year
order by
o_year

```

O_YEAR	MKT_SHARE
1995.00	0.03
1996.00	0.04

2 rows processed.  
Query Processed in 2.51 seconds.

Ended Executing this Stream at Mon Sep 6 12:37:34 2004

Stream Started at 1094492252.02  
Stream Ended at 1094492254.53  
Stream Processed in 2.51 seconds

SQL statements processed: 1

### 9.log

Begin Execution at Mon Sep 6 12:37:34 2004

-- using default substitutions

```

select
nation,
o_year,
sum(amount) as sum_profit
from
(
select
n_name as nation,
to_number (to_char (o_orderdate, 'yyyy')) as o_year,
l_extendedprice * (1 - l_discount) - ps_supplycost *
l_quantity as amount
from
part,
supplier,
lineitem,
partsupp,
orders,
nation
where
s_suppkey = l_suppkey

```

```

and ps_suppkey = l_suppkey
and ps_partkey = l_partkey
and p_partkey = l_partkey
and o_orderkey = l_orderkey
and s_nationkey = n_nationkey
and p_name like '%green%'
) profit
group by
nation,
o_year
order by
nation,
o_year desc

```

NATION	O_YEAR	SUM_PROFIT
ALGERIA	1998.00	31342867.23
ALGERIA	1997.00	57138193.02
ALGERIA	1996.00	56140140.13
ALGERIA	1995.00	53051469.65
ALGERIA	1994.00	53867582.13
ALGERIA	1993.00	54942718.13
ALGERIA	1992.00	54628034.71
ARGENTINA	1998.00	30211185.71
ARGENTINA	1997.00	50805741.75
ARGENTINA	1996.00	51923746.58
ARGENTINA	1995.00	49298625.77
ARGENTINA	1994.00	50835610.11
ARGENTINA	1993.00	51646079.18
ARGENTINA	1992.00	50410314.99
BRAZIL	1998.00	27217924.38
BRAZIL	1997.00	48378669.20
BRAZIL	1996.00	50482870.36
BRAZIL	1995.00	47623383.63
BRAZIL	1994.00	47840165.73
BRAZIL	1993.00	49054694.04
BRAZIL	1992.00	48667639.08
CANADA	1998.00	30379833.77
CANADA	1997.00	50465052.31
CANADA	1996.00	52560501.39
CANADA	1995.00	52375332.81
CANADA	1994.00	52600364.66
CANADA	1993.00	52644504.07
CANADA	1992.00	53932871.70
CHINA	1998.00	31075466.16
CHINA	1997.00	50551874.45
CHINA	1996.00	51039293.88
CHINA	1995.00	49287534.62
CHINA	1994.00	50851090.07
CHINA	1993.00	54229629.83
CHINA	1992.00	52400529.37
EGYPT	1998.00	29054433.39
EGYPT	1997.00	50627611.45
EGYPT	1996.00	49542212.84
EGYPT	1995.00	48311550.32
EGYPT	1994.00	49790644.74
EGYPT	1993.00	48904292.97
EGYPT	1992.00	49434932.62
ETHIOPIA	1998.00	28040717.27
ETHIOPIA	1997.00	47455009.87



## Appendix D

ETHIOPIA	1996.00	46491097.57	JORDAN	1993.00	47971496.10
ETHIOPIA	1995.00	46804449.30	JORDAN	1992.00	44717239.18
ETHIOPIA	1994.00	48516143.92	KENYA	1998.00	28597614.34
ETHIOPIA	1993.00	46551891.56	KENYA	1997.00	47949733.73
ETHIOPIA	1992.00	44934648.64	KENYA	1996.00	46886924.62
FRANCE	1998.00	32226407.84	KENYA	1995.00	46072338.76
FRANCE	1997.00	47121485.86	KENYA	1994.00	45772061.17
FRANCE	1996.00	47263135.50	KENYA	1993.00	46308728.23
FRANCE	1995.00	47275997.57	KENYA	1992.00	47257780.84
FRANCE	1994.00	47067209.33	MOROCCO	1998.00	26732115.58
FRANCE	1993.00	51163370.11	MOROCCO	1997.00	45637304.25
FRANCE	1992.00	47846235.33	MOROCCO	1996.00	45558221.75
GERMANY	1998.00	28624942.66	MOROCCO	1995.00	47851318.89
GERMANY	1997.00	49309074.88	MOROCCO	1994.00	46272172.94
GERMANY	1996.00	49918683.17	MOROCCO	1993.00	46764326.18
GERMANY	1995.00	52650718.72	MOROCCO	1992.00	48122783.58
GERMANY	1994.00	50346900.42	MOZAMBIQUE	1998.00	30712392.01
GERMANY	1993.00	50991895.81	MOZAMBIQUE	1997.00	50316528.76
GERMANY	1992.00	48274126.10	MOZAMBIQUE	1996.00	51640320.25
INDIA	1998.00	29943144.35	MOZAMBIQUE	1995.00	50693774.51
INDIA	1997.00	50665453.23	MOZAMBIQUE	1994.00	49253277.63
INDIA	1996.00	50283092.29	MOZAMBIQUE	1993.00	49153016.54
INDIA	1995.00	50006774.64	MOZAMBIQUE	1992.00	48247551.85
INDIA	1994.00	48995190.76	PERU	1998.00	29326102.32
INDIA	1993.00	50286902.85	PERU	1997.00	49753780.40
INDIA	1992.00	50850329.40	PERU	1996.00	50935170.29
INDONESIA	1998.00	27672340.00	PERU	1995.00	53309883.41
INDONESIA	1997.00	50512145.73	PERU	1994.00	50643531.80
INDONESIA	1996.00	51653060.12	PERU	1993.00	51584622.00
INDONESIA	1995.00	51508779.59	PERU	1992.00	47523899.05
INDONESIA	1994.00	52817950.32	ROMANIA	1998.00	30368667.40
INDONESIA	1993.00	47959994.96	ROMANIA	1997.00	50365683.85
INDONESIA	1992.00	51776605.03	ROMANIA	1996.00	49598999.01
IRAN	1998.00	29065736.24	ROMANIA	1995.00	47537642.87
IRAN	1997.00	50042063.05	ROMANIA	1994.00	51455283.01
IRAN	1996.00	50926653.19	ROMANIA	1993.00	50407136.89
IRAN	1995.00	51249667.65	ROMANIA	1992.00	48185385.13
IRAN	1994.00	50337085.87	RUSSIA	1998.00	28322384.03
IRAN	1993.00	51730763.49	RUSSIA	1997.00	50106685.18
IRAN	1992.00	49955856.56	RUSSIA	1996.00	51753342.43
IRAQ	1998.00	31624551.00	RUSSIA	1995.00	49215820.36
IRAQ	1997.00	55121749.02	RUSSIA	1994.00	52205666.44
IRAQ	1996.00	55897663.79	RUSSIA	1993.00	51860230.03
IRAQ	1995.00	54815472.52	RUSSIA	1992.00	53251677.15
IRAQ	1994.00	54408516.13	SAUDI ARABIA	1998.00	31541259.81
IRAQ	1993.00	53633167.98	SAUDI ARABIA	1997.00	52438750.81
IRAQ	1992.00	55891939.34	SAUDI ARABIA	1996.00	52543737.82
JAPAN	1998.00	27934179.67	SAUDI ARABIA	1995.00	52938696.53
JAPAN	1997.00	44517162.55	SAUDI ARABIA	1994.00	51389601.97
JAPAN	1996.00	42545606.12	SAUDI ARABIA	1993.00	52937508.88
JAPAN	1995.00	43749356.40	SAUDI ARABIA	1992.00	54843459.64
JAPAN	1994.00	44840243.07	UNITED KINGDOM	1998.00	28494874.00
JAPAN	1993.00	44660015.53	UNITED KINGDOM	1997.00	49381810.90
JAPAN	1992.00	45410249.12	UNITED KINGDOM	1996.00	51386853.96
JORDAN	1998.00	26901488.58	UNITED KINGDOM	1995.00	51509586.79
JORDAN	1997.00	45471878.41	UNITED KINGDOM	1994.00	48086499.71
JORDAN	1996.00	46794325.79	UNITED KINGDOM	1993.00	49166827.22
JORDAN	1995.00	45178828.58	UNITED KINGDOM	1992.00	49349122.08
JORDAN	1994.00	45333636.51	UNITED STATES	1998.00	25126238.95

## Appendix D

UNITED STATES	1997.00	50077306.42
UNITED STATES	1996.00	48048649.47
UNITED STATES	1995.00	48809032.42
UNITED STATES	1994.00	49296747.18
UNITED STATES	1993.00	48029946.80
UNITED STATES	1992.00	48671944.50
VIETNAM	1998.00	30442736.06
VIETNAM	1997.00	50309179.79
VIETNAM	1996.00	50488161.41
VIETNAM	1995.00	49658284.61
VIETNAM	1994.00	50596057.26
VIETNAM	1993.00	50953919.15
VIETNAM	1992.00	49613838.32

```

and o_orderdate < add_months( to_date( '1993-10-01',
'YYYY-MM-DD'), 3)
and l_returnflag = 'R'
and c_nationkey = n_nationkey
group by
c_custkey,
c_name,
c_acctbal,
c_phone,
n_name,
c_address,
c_comment
order by
revenue desc)
where rownum <= 20

```

175 rows processed.  
Query Processed in 5.43 seconds.

Ended Executing this Stream at Mon Sep 6 12:37:40 2004

Stream Started at 1094492254.59  
Stream Ended at 1094492260.02  
Stream Processed in 5.43 seconds

SQL statements processed: 1

### 10.log

Begin Execution at Mon Sep 6 12:37:40 2004

-- using default substitutions

```

select * from (
select
c_custkey,
c_name,
sum(l_extendedprice * (1 - l_discount)) as revenue,
c_acctbal,
n_name,
c_address,
c_phone,
c_comment
from
customer,
orders,
lineitem,
nation
where
c_custkey = o_custkey
and l_orderkey = o_orderkey
and o_orderdate >= to_date( '1993-10-01', 'YYYY-MM-DD')

```

C_CUSTKEY	C_NAME	REVENUE
C_ACCTBAL	N_NAME	
C_ADDRESS	C_PHONE	
C_COMMENT		
57040.00	Customer#000057040	734235.25
632.87	JAPAN	
Eioyzzf4pp	22-895-641-3466	
requests sleep blithely about the furiously i		
143347.00	Customer#000143347	721002.69
2557.47	EGYPT	
1aReFYv,Kw4	14-742-935-3718	
fluffily bold excuses haggle finally after the u		
60838.00	Customer#000060838	679127.31
2454.77	BRAZIL	
64EaJ5vMAHWJIBOXJklpNc2RJiWE	12-913-494-9813	
furiously even pinto beans integrate under the ruthless foxes;		
ironic, even dolphins across the slyl		
101998.00	Customer#000101998	637029.57
3790.89	UNITED KINGDOM	
01c9CILnNtfOQYmZj	33-593-865-6378	
accounts doze blithely! enticing, final deposits sleep blithely		
special accounts. slyly express accounts pla		
125341.00	Customer#000125341	633508.09
4983.51	GERMANY	
S29ODD6bceU8QSuuEJznkNaK	17-582-695-5962	
quickly express requests wake quickly blithely		
25501.00	Customer#000025501	620269.78
7725.04	ETHIOPIA	
W556MXuoiaYCCZamJI,Rn0B4ACUGdkQ8DZ	15-874-808-6793	
quickly special requests sleep evenly among the special		
deposits. special deposi		
115831.00	Customer#000115831	596423.87
5098.10	FRANCE	
rFeBbEEyk dl ne7zV5fDrmiq1oK09wV7pxqCglc	16-715-386-3788	
carefully bold excuses sleep alongside of the thinly idle		
84223.00	Customer#000084223	594998.02
528.65	UNITED KINGDOM	
nAVZCs6BaWap rrM27N 2qBnzc5WBauxbA	33-442-824-8191	

## Appendix D

pending, final ideas haggle final requests. unusual, regular asymptotes affix according to the even foxes.

54289.00	Customer#000054289	585603.39
5583.02	IRAN	
vXCxocsU0Bad5JQI ,oobkZ 20-834-292-4707		

express requests sublate blithely regular requests. regular, even ideas solve.

39922.00	Customer#000039922	584878.11
7321.11	GERMANY	
Zgy4s50l2GKN4pLDPBU8m342glw6R 17-147-757-8036		

even pinto beans haggle. slyly bold accounts inte

6226.00	Customer#000006226	576783.76
2230.09	UNITED KINGDOM	
8gPu8,NPGkfyQQ0hcIYUGPIBWc,ybP5g, 33-657-701-3391		

quickly final requests against the regular instructions wake blithely final instructions. pa

922.00	Customer#000000922	576767.53
3869.25	GERMANY	
Az9RFaut7NkPnc5zSD2PwHgVwr4jRzq 17-945-916-9648		

boldly final requests cajole blith

147946.00	Customer#000147946	576455.13
2030.13	ALGERIA	
iANyZHjqhy7Ajah0pTrYyhJ 10-886-956-3143		

furiously even accounts are blithely above the furiousl

115640.00	Customer#000115640	569341.19
6436.10	ARGENTINA	
Vtgfia9qI 7EpHgecU1X 11-411-543-4901		

final instructions are slyly according to the

73606.00	Customer#000073606	568656.86
1785.67	JAPAN	
xuR0Tro5yChDfOCrjkd2ol 22-437-653-6966		

furiously bold orbits about the furiously busy requests wake across the furiously quiet theodolites. d

110246.00	Customer#000110246	566842.98
7763.35	VIETNAM	
7KzflgX MDOq7sOkI 31-943-426-9837		

dolphins sleep blithely among the slyly final

142549.00	Customer#000142549	563537.24
5085.99	INDONESIA	
ChqEoK43OysjdHbtKCP6dKqjNyvvi9 19-955-562-2398		

regular, unusual dependencies boost slyly; ironic attainments nag fluffily into the unusual packages?

146149.00	Customer#000146149	557254.99
1791.55	ROMANIA	
s87fvzFQpU 29-744-164-6487		

silent, unusual requests detect quickly slyly regul

52528.00	Customer#000052528	556397.35
551.79	ARGENTINA	
NFztyTOR10UOJ 11-208-192-3205		

unusual requests detect. slyly dogged theodolites use slyly. deposit

23431.00	Customer#000023431	554269.54
3381.86	ROMANIA	
HgiV0phqhala9aydNoIlb 29-915-458-2654		

instructions nag quickly. furiously bold accounts cajol

20 rows processed.  
Query Processed in 2.54 seconds.

Ended Executing this Stream at Mon Sep 6 12:37:42 2004

Stream Started at 1094492260.08  
Stream Ended at 1094492262.62  
Stream Processed in 2.54 seconds

SQL statements processed: 1

### 11.log

Begin Execution at Mon Sep 6 12:37:42 2004

-- using default substitutions

```

select
ps_partkey,
sum(ps_supplycost * ps_availqty) as value
from
partsupp,
supplier,
nation
where
ps_suppkey = s_suppkey
and s_nationkey = n_nationkey
and n_name = 'GERMANY'
group by
ps_partkey having
sum(ps_supplycost * ps_availqty) > (
select
sum(ps_supplycost * ps_availqty) *
0.0001000000
from
partsupp,
supplier,
nation
where
ps_suppkey = s_suppkey
and s_nationkey = n_nationkey
and n_name = 'GERMANY'
)
order by
value desc

```

PS_PARTKEY	VALUE
129760.00	17538456.86

## Appendix D

166726.00	16503353.92	43536.00	11779340.52
191287.00	16474801.97	9552.00	11776909.16
161758.00	16101755.54	86223.00	11772205.08
34452.00	15983844.72	53776.00	11758669.65
139035.00	15907078.34	131285.00	11616953.74
9403.00	15451755.62	91628.00	11611114.83
154358.00	15212937.88	----- <rows truncated>	-----
38823.00	15064802.86		
85606.00	15053957.15		
33354.00	14408297.40		
154747.00	14407580.68	72073.00	7877736.11
82865.00	14235489.78	5182.00	7874521.73
76094.00	14094247.04		
222.00	13937777.74		
121271.00	13908336.00	1048 rows processed.	
55221.00	13716120.47	Query Processed in 0.97 seconds.	
22819.00	13666434.28		
76281.00	13646853.68		
85298.00	13581154.93	Ended Executing this Stream at Mon Sep 6	
85158.00	13554904.00	12:37:43 2004	
139684.00	13535538.72		
31034.00	13498025.25		
87305.00	13482847.04	Stream Started at 1094492262.68	
10181.00	13445148.75	Stream Ended at 1094492263.65	
62323.00	13411824.30	Stream Processed in 0.97 seconds	
26489.00	13377256.38		
96493.00	13339057.83		
56548.00	13329014.97	SQL statements processed: 1	
55576.00	13306843.35		
159751.00	13306614.48		
92406.00	13287414.50		
182636.00	13223726.74	<b>12.log</b>	
199969.00	13135288.21		
62865.00	13001926.94	Begin Execution at Mon Sep 6 12:37:43 2004	
7284.00	12945298.19		
197867.00	12944510.52		
11562.00	12931575.51		
75165.00	12916918.12		
97175.00	12911283.50		
140840.00	12896562.23	-- using default substitutions	
65241.00	12890600.46		
166120.00	12876927.22		
9035.00	12863828.70	select	
144616.00	12853549.30	l_shipmode,	
176723.00	12832309.74	sum(case	
170884.00	12792136.58	when o_orderpriority = '1-URGENT'	
29790.00	12723300.33	or o_orderpriority = '2-HIGH'	
95213.00	12555483.73	then 1	
183873.00	12550533.05	else 0	
171235.00	12476538.30	end) as high_line_count,	
21533.00	12437821.32	sum(case	
17290.00	12432159.50	when o_orderpriority <> '1-URGENT'	
156397.00	12260623.50	and o_orderpriority <> '2-HIGH'	
122611.00	12222812.98	then 1	
139155.00	12220319.25	else 0	
146316.00	12215800.61	end) as low_line_count	
171381.00	12199734.52	from	
198633.00	12078226.95	orders,	
167417.00	12046637.62	lineitem	
59512.00	12043468.76	where	
31688.00	12034893.64	o_orderkey = l_orderkey	
159586.00	12001505.84	and l_shipmode in ('MAIL', 'SHIP')	
8993.00	11963814.30		
120302.00	11857707.55		

## Appendix D

```

and l_commitdate < l_receiptdate
and l_shipdate < l_commitdate
and l_receiptdate >= to_date('1994-01-01', 'YYYY-MM-
DD')
and l_receiptdate < add_months(to_date('1994-01-01',
'YYYY-MM-DD'), 12)
group by
    l_shipmode
order by
    l_shipmode

L_SHIPMODE HIGH_LINE_COUNT
LOW_LINE_COUNT
MAIL      6202.00      9324.00
SHIP      6200.00      9262.00

```

2 rows processed.  
Query Processed in 1.72 seconds.

Ended Executing this Stream at Mon Sep 6 12:37:45 2004

Stream Started at 1094492263.72  
Stream Ended at 1094492265.44  
Stream Processed in 1.72 seconds

SQL statements processed: 1

### 13.log

Begin Execution at Mon Sep 6 12:37:45 2004

-- using default substitutions

```

select
c_count,
count(*) as custdist
from
(
select
c_custkey,
count(o_orderkey) as c_count
from
customer, orders where
c_custkey = o_custkey(+)
and o_comment(+) not like '%special%requests%'
group by
c_custkey
) c_orders
group by

```

```

c_count
order by
custdist desc,
c_count desc

```

C_COUNT	CUSTDIST
0.00	50004.00
9.00	6641.00
10.00	6566.00
11.00	6058.00
8.00	5949.00
12.00	5553.00
13.00	4989.00
19.00	4748.00
7.00	4707.00
18.00	4625.00
15.00	4552.00
17.00	4530.00
14.00	4484.00
20.00	4461.00
16.00	4323.00
21.00	4217.00
22.00	3730.00
6.00	3334.00
23.00	3129.00
24.00	2622.00
25.00	2079.00
5.00	1972.00
26.00	1593.00
27.00	1185.00
4.00	1033.00
28.00	869.00
29.00	559.00
3.00	398.00
30.00	373.00
31.00	235.00
2.00	144.00
32.00	128.00
33.00	71.00
34.00	48.00
35.00	33.00
1.00	23.00
36.00	17.00
37.00	7.00
40.00	4.00
38.00	4.00
39.00	2.00
41.00	1.00

42 rows processed.  
Query Processed in 3.05 seconds.

Ended Executing this Stream at Mon Sep 6 12:37:48 2004

Stream Started at 1094492265.50  
Stream Ended at 1094492268.55

## Appendix D

Stream Processed in 3.05 seconds

SQL statements processed: 1

### 14.log

Begin Execution at Mon Sep 6 12:37:48 2004

-- using default substitutions

```
select
    100.00 * sum(case
        when p_type like 'PROMO%'
            then l_extendedprice * (1 -
l_discount)
            else 0
        end) / sum(l_extendedprice * (1 - l_discount)) as
promo_revenue
from
    lineitem,
    part
where
    l_partkey = p_partkey
    and l_shipdate >= date '1995-09-01'
    and l_shipdate < date '1995-09-01' + interval '1'
month
```

PROMO\_REVENUE  
16.38

1 row processed.  
Query Processed in 0.35 seconds.

Ended Executing this Stream at Mon Sep 6 12:37:48 2004

Stream Started at 1094492268.62  
Stream Ended at 1094492268.97  
Stream Processed in 0.35 seconds

SQL statements processed: 1

### 15.log

Begin Execution at Mon Sep 6 12:37:49 2004

-- using default substitutions

```
with revenue
as (select
    l_suppkey supplier_no,
    sum(l_extendedprice * (1 - l_discount)) total_revenue
    from
    lineitem
    where
        l_shipdate >= date '1996-01-01'
        and l_shipdate < date '1996-01-01' + interval '3'
    month
    group by
    l_suppkey)
select
    s_suppkey,
    s_name,
    s_address,
    s_phone,
    total_revenue
    from
    supplier,
    revenue
    where
    s_suppkey = supplier_no
    and total_revenue = (
    select
    max(total_revenue)
    from
    revenue )
    order by
    s_suppkey
```

S_SUPPKEY	S_NAME	S_ADDRESS	S_PHONE
8449.00	Supplier#000008449	Wp34zim9qYFbVctdW	20-469-856-8873
1772627.21			

1 row processed.  
Query Processed in 2.29 seconds.

Ended Executing this Stream at Mon Sep 6 12:37:51 2004

Stream Started at 1094492269.03  
Stream Ended at 1094492271.31  
Stream Processed in 2.29 seconds

SQL statements processed: 1

### 16.log

Begin Execution at Mon Sep 6 12:37:51 2004

-- using default substitutions

## Appendix D

```

select
p_brand,
p_type,
p_size,
count(distinct ps_suppkey) as supplier_cnt
from
partsupp,
part
where
p_partkey = ps_partkey
and p_brand <> 'Brand#45'
and p_type not like 'MEDIUM POLISHED%'
and p_size in (49, 14, 23, 45, 19, 3, 36, 9)
and ps_suppkey not in (
select
s_suppkey
from
supplier
where
s_comment like '%Customer%Complaints%'
)
group by
p_brand,
p_type,
p_size
order by
supplier_cnt desc,
p_brand,
p_type,
p_size

```

P_BRAND	P_TYPE	P_SIZE	SUPPLIER_CNT
Brand#41	MEDIUM BRUSHED TIN	3.00	28.00
Brand#54	STANDARD BRUSHED COPPER	14.00	27.00
Brand#11	STANDARD BRUSHED TIN	23.00	24.00
Brand#11	STANDARD BURNISHED BRASS	36.00	24.00
Brand#15	MEDIUM ANODIZED NICKEL	3.00	24.00
Brand#15	SMALL ANODIZED BRASS	45.00	24.00
Brand#15	SMALL BURNISHED NICKEL	19.00	24.00
Brand#21	MEDIUM ANODIZED COPPER	3.00	24.00
Brand#22	SMALL BRUSHED NICKEL	3.00	24.00
Brand#22	SMALL BURNISHED BRASS	19.00	24.00

----- <rows truncated>  
-----

18314 rows processed.  
Query Processed in 0.76 seconds.

Ended Executing this Stream at Mon Sep 6 12:37:52 2004

Stream Started at 1094492271.37  
Stream Ended at 1094492272.13  
Stream Processed in 0.76 seconds

SQL statements processed: 1

### 17.log

Begin Execution at Mon Sep 6 12:37:52 2004

-- using default substitutions

```

select
sum(l_extendedprice) / 7.0 as avg_yearly
from
lineitem ,
part
where
p_partkey = l_partkey
and p_brand = 'Brand#23'
and p_container = 'MED BOX'
and l_quantity < (
select
0.2 * avg(l_quantity)
from
lineitem
where
l_partkey = p_partkey
)

```

AVG\_YEARLY  
348406.05

1 row processed.  
Query Processed in 1.97 seconds.

Ended Executing this Stream at Mon Sep 6 12:37:54 2004

Stream Started at 1094492272.19  
Stream Ended at 1094492274.16  
Stream Processed in 1.97 seconds

SQL statements processed: 1

## Appendix D

### 18.log

Begin Execution at Mon Sep 6 12:37:54 2004

-- using default substitutions

```
select * from (
select
c_name,
c_custkey,
o_orderkey,
o_orderdate,
o_totalprice,
sum(l_quantity)
from
customer,
orders,
lineitem
where
o_orderkey in (
select
l_orderkey
from
lineitem
group by
l_orderkey having
sum(l_quantity) > 300
)
and c_custkey = o_custkey
and o_orderkey = l_orderkey
group by
c_name,
c_custkey,
o_orderkey,
o_orderdate,
o_totalprice
order by
o_totalprice desc,
o_orderdate
)
where rownum <= 100
```

C_NAME	C_CUSTKEY	O_ORDERKEY
O_ORDERDATE		
O_TOTALPRICE	SUM(L_QUANTITY)	
Customer#000128120	128120.00	4722021.00
1994-04-07		
544089.09	323.00	
Customer#000144617	144617.00	3043270.00
1997-02-12		
530604.44	317.00	
Customer#000013940	13940.00	2232932.00
1997-04-13		
522720.61	304.00	
Customer#000066790	66790.00	2199712.00
1996-09-30		

515531.82	327.00	
Customer#000046435	46435.00	4745607.00
1997-07-03		
508047.99	309.00	
Customer#000015272	15272.00	3883783.00
1993-07-28		
500241.33	302.00	
Customer#000146608	146608.00	3342468.00
1994-06-12		
499794.58	303.00	
Customer#000096103	96103.00	5984582.00
1992-03-16		
494398.79	312.00	
Customer#000024341	24341.00	1474818.00
1992-11-15		
491348.26	302.00	
Customer#000137446	137446.00	5489475.00
1997-05-23		
487763.25	311.00	
Customer#000107590	107590.00	4267751.00
1994-11-04		
485141.38	301.00	
Customer#000050008	50008.00	2366755.00
1996-12-09		
483891.26	302.00	
Customer#000015619	15619.00	3767271.00
1996-08-07		
480083.96	318.00	
Customer#000077260	77260.00	1436544.00
1992-09-12		
479499.43	307.00	
Customer#000109379	109379.00	5746311.00
1996-10-10		
478064.11	302.00	
Customer#000054602	54602.00	5832321.00
1997-02-09		
471220.08	307.00	
Customer#000105995	105995.00	2096705.00
1994-07-03		
469692.58	307.00	
Customer#000148885	148885.00	2942469.00
1992-05-31		
469630.44	313.00	
Customer#000114586	114586.00	551136.00
1993-05-19		
469605.59	308.00	
Customer#000105260	105260.00	5296167.00
1996-09-06		
469360.57	303.00	
Customer#000147197	147197.00	1263015.00
1997-02-02		
467149.67	320.00	
Customer#000064483	64483.00	2745894.00
1996-07-04		
466991.35	304.00	
Customer#000136573	136573.00	2761378.00
1996-05-31		
461282.73	301.00	



## Appendix D

Customer#000016384	16384.00	502886.00	433525.97	301.00	
1994-04-12			Customer#000113131	113131.00	967334.00
458378.92	312.00		1995-12-15		
Customer#000117919	117919.00	2869152.00	432957.75	301.00	
1996-06-20			Customer#000141098	141098.00	565574.00
456815.92	317.00		1995-09-24		
Customer#000012251	12251.00	735366.00	430986.69	301.00	
1993-11-24			Customer#000093392	93392.00	5200102.00
455107.26	309.00		1997-01-22		
Customer#000120098	120098.00	1971680.00	425487.51	304.00	
1995-06-14			Customer#000015631	15631.00	1845057.00
453451.23	308.00		1994-05-12		
Customer#000066098	66098.00	5007490.00	419879.59	302.00	
1992-08-07			Customer#000112987	112987.00	4439686.00
453436.16	304.00		1996-09-17		
Customer#000117076	117076.00	4290656.00	418161.49	305.00	
1997-02-05			Customer#000012599	12599.00	4259524.00
449545.85	301.00		1998-02-12		
Customer#000129379	129379.00	4720454.00	415200.61	304.00	
1997-06-07			Customer#000105410	105410.00	4478371.00
448665.79	303.00		1996-03-05		
Customer#000126865	126865.00	4702759.00	412754.51	302.00	
1994-11-07			Customer#000149842	149842.00	5156581.00
447606.65	320.00		1994-05-30		
Customer#000088876	88876.00	983201.00	411329.35	302.00	
1993-12-30			Customer#000010129	10129.00	5849444.00
446717.46	304.00		1994-03-21		
Customer#000036619	36619.00	4806726.00	409129.85	309.00	
1995-01-17			Customer#000069904	69904.00	1742403.00
446704.09	328.00		1996-10-19		
Customer#000141823	141823.00	2806245.00	408513.00	305.00	
1996-12-29			Customer#000017746	17746.00	6882.00
446269.12	310.00		1997-04-09		
Customer#000053029	53029.00	2662214.00	408446.93	303.00	
1993-08-13			Customer#000013072	13072.00	1481925.00
446144.49	302.00		1998-03-15		
Customer#000018188	18188.00	3037414.00	399195.47	301.00	
1995-01-25			Customer#000082441	82441.00	857959.00
443807.22	308.00		1994-02-07		
Customer#000066533	66533.00	29158.00	382579.74	305.00	
1995-10-21			Customer#000088703	88703.00	2995076.00
443576.50	305.00		1994-01-30		
Customer#000037729	37729.00	4134341.00	363812.12	302.00	
1995-06-29					
441082.97	309.00				
Customer#000003566	3566.00	2329187.00			
1998-01-04					
439803.36	304.00				
Customer#000045538	45538.00	4527553.00			
1994-05-22					
436275.31	305.00				
Customer#000081581	81581.00	4739650.00			
1995-11-04					
435405.90	305.00				
Customer#000119989	119989.00	1544643.00			
1997-09-20					
434568.25	320.00				
Customer#000003680	3680.00	3861123.00			
1998-07-03					

57 rows processed.  
Query Processed in 10.65 seconds.

Ended Executing this Stream at Mon Sep 6 12:38:04 2004

Stream Started at 1094492274.23  
Stream Ended at 1094492284.88  
Stream Processed in 10.65 seconds

SQL statements processed: 1

## Appendix D

### 19.log

Begin Execution at Mon Sep 6 12:38:04 2004

-- using default substitutions

```
select
sum(l_extendedprice* (1 - l_discount)) as revenue
from
lineitem,
part
where
(
p_partkey = l_partkey
and p_brand = 'Brand#12'
and p_container in ('SM CASE', 'SM BOX', 'SM PACK', 'SM
PKG')
and l_quantity >= 1 and l_quantity <= 1 + 10
and p_size between 1 and 5
and l_shipmode in ('AIR', 'AIR REG')
and l_shipinstruct = 'DELIVER IN PERSON'
)
or
(
p_partkey = l_partkey
and p_brand = 'Brand#23'
and p_container in ('MED BAG', 'MED BOX', 'MED PKG',
'MED PACK')
and l_quantity >= 10 and l_quantity <= 10 + 10
and p_size between 1 and 10
and l_shipmode in ('AIR', 'AIR REG')
and l_shipinstruct = 'DELIVER IN PERSON'
)
or
(
p_partkey = l_partkey
and p_brand = 'Brand#34'
and p_container in ('LG CASE', 'LG BOX', 'LG PACK', 'LG
PKG')
and l_quantity >= 20 and l_quantity <= 20 + 10
and p_size between 1 and 15
and l_shipmode in ('AIR', 'AIR REG')
and l_shipinstruct = 'DELIVER IN PERSON'
)
```

REVENUE  
3083843.06

1 row processed.  
Query Processed in 3.08 seconds.

Ended Executing this Stream at Mon Sep 6 12:38:08 2004

Stream Started at 1094492284.94

96

Stream Ended at 1094492288.01  
Stream Processed in 3.08 seconds

SQL statements processed: 1

### 20.log

Begin Execution at Mon Sep 6 12:38:08 2004

-- using default substitutions

```
select
s_name,
s_address
from
supplier,
nation
where
s_suppkey in (
select
ps_suppkey
from
partsupp
where
ps_partkey in (
select
p_partkey
from
part
where
p_name like 'forest%'
)
and ps_availqty > (
select
0.5 * sum(l_quantity)
from
lineitem
where
l_partkey = ps_partkey
and l_suppkey = ps_suppkey
and l_shipdate >= to_date ('1994-01-01', 'YYYY-MM-DD')
and l_shipdate < add_months( to_date ('1994-01-01', 'YYYY-
MM-DD'), 12)
)
)
and s_nationkey = n_nationkey
and n_name = 'CANADA'
order by
s_name
```

S\_NAME S\_ADDRESS  
Supplier#000000020 iybAE,RmTymrZVYafZva2SH,j  
Supplier#000000091  
YV45D7TkfdQanOOZ7q9QxkyGUapU1oOWU6q3  
Supplier#000000197  
YC2Acon6kjY3zj3Fbxs2k4Vdf7X0cd2F

## Appendix D

Supplier#00000226	83qOdU2EYRdPQAQhEtn GRZEd	Supplier#000002571	JZUugz04c iJFLrIGsz9O N,W
Supplier#00000285	Br7e1nnt1yxrw6ImgpJ7YdhFDjuBf	1rVHNIReyq	
Supplier#00000378	FfbhyCxWvcPrO8ltp9	Supplier#000002585	
Supplier#00000402		CsPoKpw2QuTY4AV1NkWuttneIa4SN	
i9Sw4DoyMhzhKXCH9By,AYSgmD		Supplier#000002630	ZIQAvjNUY9KH5ive zm7k
Supplier#00000530	0qwCMwobKY	VIPiD17CCo21	
OcmLyfRXlagA8ukENJv,		Supplier#000002719	
Supplier#00000688	D	4nnzQI2CbqREQUuIsXTBVUkaP4mNS3	
fw5ocppmZpYBBIP1718hCihLDZ5KhKX		Supplier#000002721	HVdFAN2JHMQSpKm
Supplier#00000710	f19YPvOyb	Supplier#000002730	lIFxR4fzm31C6,muzJwl84z
QoYwjKC,oPycpGfieBAcwKJo		Supplier#000002775	yDclaDaBD4ihH
Supplier#00000736		Supplier#000002853	rTNAOIxtXka
l6i2nMwVuovfKnuVgaSGK2rDy65DIAFLegil7		Supplier#000002875	6JgMi
Supplier#00000761		9Qt6VmwL3Ltt1SRIKww0keLQ,RAZA	
zlSLeIQUj2XrvTTFnv7WAcYZGvvMTx882d4		Supplier#000002934	m,trBENywsARwg3DhB
Supplier#00000884	bmhEShejaS	Supplier#000002941	Naddba 8YTEKekZyP0
Supplier#00000887	urEaTejH5POADP2ARrf	Supplier#000002960	
Supplier#00000935	ij98czM	KCPCEsRGG06vx8TygHh60nAYf9rStQT2T	
2KzWe7dDT0xB8sq0UfCdvrx		Supplier#000002980	
Supplier#00000975	,AC e,tBpNwKb5xMUzeohxIRn,	B9k9yVsyaXvWktOSHezqHiAEp9id0SKzkw	
hdZJo73gFQF8y		Supplier#000003062	
Supplier#000001263	rQWr6nf8ZhB2TAiIDivo5Io	LSQNqgY1xnOzz9zBCapy7HwOZQ	
Supplier#000001399	LmrocnIMSyYOWuANx7	Supplier#000003087	ANwe8QsZ4rgj1HSqVz991eWQ
Supplier#000001446	lch9HMNU1R7a0LIybsUodVknk6	Supplier#000003089	s5b VCIZqMSZVa r
Supplier#000001454	TOpimgu2TVXIjhiL93h,	g7LTdcg29GbTE7r1x	
Supplier#000001500	wDmF5xLxtQch9ctVu,	Supplier#000003095	HxON3jJhUi3zjt,r mTD
Supplier#000001602	uKNWleafaM644	Supplier#000003201	
Supplier#000001626	UhxNRzUu1dtFmp0	E87yws6L,t0qNs4QW7UzExKiJnJDZWue	
Supplier#000001682	pXTkGxrTQVyH1Rr	Supplier#000003213	pxrRP4irQ1VoyfQ,dTf3
Supplier#000001699	Q9C4rfJ26oijVPqqcqVXeRI	Supplier#000003241	j06SU,LS9O3mwjAMOVIANelhb
Supplier#000001700	7hMlCoflY5zLFg	Supplier#000003275	9xO4nyJ2QJcX6vGf
Supplier#000001726	TeRY7TtTH24sEword7yAaSkjx8	Supplier#000003288	
Supplier#000001730	Rc8e,1Pybn r6zo0VJIEiD0UD vhk	EDdfNt7E5Uc,xLTupoIgL4yY7ujh,	
Supplier#000001746		Supplier#000003313	
qWsendlOekQG1aW4uq06uQaCm51se8lirv7 hBRd		El2I7we,049SPrvomUm4hZwJoOhZkvLxLJXgVH	
Supplier#000001752	Fra7outx41THYJaRThdOGiBk	Supplier#000003314	
Supplier#000001856		jnisU8MzqO4iUB3zsPcrysMw3DDUoJ54q7LD	
jXcRgzYF0ah05iR8p6w5SbJLcUGyYiURPvFwUWM		Supplier#000003380	
Supplier#000001931	FpJbMU2h6ZR2eBv8I9NIxF	jPv0V,pszouuFT3YsAqIP,kxT3u,gTFIEbRt,x	
Supplier#000001939	Nrk,JA4bfReUs	Supplier#000003403	e3X2o ,KCG9tsHji8A
Supplier#000001990		XXCxiF2hZWBw	
DSDJkCgBJzuPg1yuM,CUdLnsRliOxkkHezTCA		Supplier#000003421	Sh3dt9W5oeofFWovnfHrg,
Supplier#000002020	jB6r1d7MxP6co	Supplier#000003441	zvFJlZs,oUuShHjpcX
Supplier#000002022	dwebGX7Id2pc25YvY33	Supplier#000003590	sy79CMLxqb,Cbo
Supplier#000002036	20ytTtVObjKUUI2WCB0A	Supplier#000003607	lNqFHQYjwSAkf
Supplier#000002204		Supplier#000003625	
uYmlr46C06udCqanj0KiRsoTQakZsEyssL		qY588W0Yk5iaUy1RXTgNrEKrMAjBYHcKs	
Supplier#000002243	nSOEV3JeOU79	Supplier#000003656	eEYmmO2gmD
Supplier#000002245		JdfG32XtDgJV,db56	
hz2qWXWVjOyKhqPYMoEwz6zFkrTaDM		Supplier#000003782	
Supplier#000002282		iVsPZg7bk06TqNMwi0LKbLUrC1zmrg	
ES21K9dxoW111TzWCj7ekdlNwSWnv1Z 6mQ,BKn		Supplier#000003918	meRvRCsJoAbfqd0Re4
Supplier#000002303	nCoWfpB6YOymbgOht7lftklpkHI	Supplier#000003941	Pmb05mQfBMS618O7WKqZJ
Supplier#000002373	RzHSxOTQmEicjxiBiVA5Z2	9vyv	
JB58rJhPRyIR		Supplier#000003994	W00LZp3NjK0
Supplier#000002419	qydBQd14I515mVXa4fYY	Supplier#000004005	
Supplier#000002481		V723F1wCy2eA4Oglu8TjBtOVUHp	
nLKHUOn2M19TOA06Znq9GEMcIIIMO2		Supplier#000004033	ncsAhv9Je,kFXTNjfb2
		Supplier#000004140	0hL7DJyYjchL

## Appendix D

Supplier#000004165		Supplier#000005989	rfFY,5kgLpBu7c
wTJ2dZnQA8P2oi99N6DT47ndHy,XKD2		Supplier#000006059	4m0cv8MwJ9yX2vIwI Z
Supplier#000004207		Supplier#000006065	UiI2Cy3W4Tu5sLk
tF64pwiOM4IkWjN3mS,e06WuAjLx		LuvXLRY6KihlGv	
Supplier#000004236		Supplier#000006070	TalC5m0pDrO6DZbngfmGmqe
dl,HPTJmGipxYsSqN9wmqkuWjst,mCeJ8O6T		Supplier#000006109	rY5gbfh3dKHnycQUTPGCwnbe
Supplier#000004246	Xha aXQF7u4qU3LsHD	Supplier#000006121	
Supplier#000004278	bBddbPbXIVp Di9	S92ycWwEzYYw4GspCBJN1WMuHhoZ	
Supplier#000004343	GK3sbopqrQEkWLMvVBFCG	Supplier#000006215	j2iEbTsl,5PWdqWZ7k1yilSb7qtiiZljDIPEo
Supplier#000004346	S3076LEOwo	Supplier#000006217	RVN23SYT9jenUeaWGXUd
Supplier#000004388	VfZ 1lJ,mwp4aS	Supplier#000006274	S3yTZWqxTKUq g QQgcW9
Supplier#000004406		AqhCkNZsW51hHuwU	
Ah0ZaLu6VwufPWUz,7kbXgYZhauEaHqGlg		Supplier#000006435	xIge69XszYbnO4Eon7cHHO8y
Supplier#000004430		Supplier#000006463	7 wkdj2EO49iotley2kmlM
yvSsKNSTL5HLXBET4luOsPNLxKzAMk		ADpLSszGV3RNWj	
Supplier#000004522		Supplier#000006493	ojV
xXtCKwsZDArxIBGDfzX2PpogGZsBg		f,sNaB6Hm7r,fknDVTl63raJgAjZK	
Supplier#000004527	p	Supplier#000006521	b9 2zjHzxR
pVXCnxgcklWF6A1o3OHY3qW6		Supplier#000006607	3F 2e2gqD5u5B
Supplier#000004542	NJSbLJDroYG2y1r3rDiKg	Supplier#000006706	
Supplier#000004574	1HvGwnVueZ5CIndc	Ak4ga,ePu1QZ6C3qkrqjosaX0gxvqS9vkbe	
Supplier#000004655	67NqBc4 t3PG3F8aO	Supplier#000006761	n4jhxGMqB5prD1HhpLvvrWStOLlla
IsqWNq4kGaPowYL		Supplier#000006808	HGd2Xo
Supplier#000004701	6jX4u47URzIMHF	9nEcHJhZvXjXxWKIpApT	
Supplier#000004711	bEzjp1QdQu ls2ERMxv0km	Supplier#000006858	fnlINT885vBBhsWwTGiZ0o22thwGY16h GHJj21
vn6bu2zXIL1		Supplier#000006872	XIDPiA7PLXCWK6SeEclD
Supplier#000004987	UFx1upJ8MvOvgFjA8	Supplier#000006949	mLxYUJhsGcLtKe
Supplier#000005000	DeX804 w0H8FrCUvahgy	,GFirNu183AvT	
ilbuzBX3NK		Supplier#000006985	PrUUiboQpy,OtgJ01Z4BxJQUyrw9c3I
Supplier#000005100	OfvYpS3Io,wEvvLHNaLuCX	Supplier#000007072	2tRyX9M1a
Supplier#000005192	JDp4rhXiDw0kf6RH	4Rcm57s779F1ANG9jlpK	
Supplier#000005195	Woi3b2ZaicPh ZSfu1EfXhE	Supplier#000007098	G3j8g0KC4OcbAu2OVOPhrXQWMCUdjQ8wgCHOExu
Supplier#000005283	5fxYXxwXy,TQX,MqDC2hxzyQ	Supplier#000007135	ls DoKV7V5ulfQy9V
Supplier#000005300	gXG28YqpxU	Supplier#000007160	TqDGBULB3cTqIT6FKDvm9BS4e4v,zwYiQPb
Supplier#000005386	Ub6AAfHpWLWP	Supplier#000007169	tEc95D2moN9S84nd55O,dlnW
Supplier#000005426	9Dz2OVT1q	Supplier#000007322	wr7dgte5q
sb4BK71ljQ1XjPBYRPvO		MAjiY0uwmi3MyDkSMX1	
Supplier#000005484	saFdOR	Supplier#000007365	51xhROLvQMj05DndtZWt
qW7AFY,3asPqiiAa11Mo22pCoN0BtPrKo		Supplier#000007398	V8eE6oZ00OFNU,
Supplier#000005505	d2sbjG43KwMPX	Supplier#000007402	4UVv58ery1rjmqrSR5
Supplier#000005506	On f5ypzoWgB	Supplier#000007448	yhhpWiJi7EJ6Q5VCaQ
Supplier#000005516		Supplier#000007477	
XsN99Ks9wEvcohU6jRD2MeebQFf76mD8vovuY		9m9j0wfhWzCvVHxkU,PpAxwSH0h	
Supplier#000005536		Supplier#000007509	q8,V6LJRoHJjHcOuSG7aLTMg
Nzo9tGkpgbHT,EZ4D,77MYK14ah1C		Supplier#000007561	rMcFg2530VC
Supplier#000005605	7Vj6Eil0mThqkM	Supplier#000007789	rQ7cUcPrtudOyO3svNSkimqH6qrfWT2Sz
Supplier#000005631		Supplier#000007801	69fi,U1r6enUb
14TVrjlzo2SJEByCDgpMwTlvwSqC		Supplier#000007818	yhhc2CQec Jrvc8zqBi83
Supplier#000005730	5rkb0PSevs	Supplier#000007885	
HvxkL8JaD41UpnSF2cg8H1		u3sicchh5ZpyTUpN1cJKNcAoabIWgY	
Supplier#000005736	2dq XTYhtYWSfp	Supplier#000007918	r,v9mBQ6LoEYyj1
Supplier#000005737	dmEWcS32C3kx,d,B95 OmYn48	Supplier#000007926	ErzCF80K9Uy
Supplier#000005797	,o,OebwRbSDmV19gN9fpWPCiqB		
UogvISR			
Supplier#000005836	tx3SjPD2ZuWGFBRH,		
Supplier#000005875			
IK,sYiGzB94hSyHy9xvSZFbVQNCZe2LXZuGbS			
Supplier#000005974			
REhR5jE,iLusQXvf54SwYySgsSSVFhu			

## Appendix D

Supplier#000007957 ELwnio14ssoU1 dRyZIL OK3VtzB Query Processed in 0.89 seconds.  
Supplier#000007965 F7Un5lJ7p5hhj  
Supplier#000007968  
DsF9UIZ2Fo6HXN9aErvyg1ikHoD582HSGZpP Ended Executing this Stream at Mon Sep 6 12:38:08 2004  
Supplier#000007998  
LnASFBfYRFOo9d6d,asBvVq9Lo2P  
Supplier#000008168 aOa82a8ZbKcfnDLX Stream Started at 1094492288.07  
Supplier#000008231 IK7eGw Yj90sTdpsP,vcqWxLB Stream Ended at 1094492288.96  
Supplier#000008243 2AyePMkDqzmzVzjGTizXthFLo8h Stream Processed in 0.89 seconds  
EiudCMxOmIIG  
Supplier#000008275 BlbNDfWg,gpXKQILN  
Supplier#000008323 75l18sZmASwm SQL statements processed: 1  
POeheRMdj9tmpyeQ,BfCXN5BIAb  
Supplier#000008366 **21.log**  
h778cEj14BuW9OEKlvPTWq4iwASR6EBBXN7zeS8 Begin Execution at Mon Sep 6 12:38:09 2004  
Supplier#000008423  
RQhKnkAhR0DAR3Ix4QlweMMn00hNe Kq  
Supplier#000008480 4sSDA4ACReklNjEm5T6b  
Supplier#000008532 -- using default substitutions  
Uc29q4,5xVdDOF87UZrxhr4xWS0ihEUXuh  
Supplier#000008595 MH0iB73GQ3z UW3O DbCbqmc  
Supplier#000008610 select \* from (  
SgVgP90vP452sUNTgzL9zKwXHXAzV6tV select  
Supplier#000008705 aE,trRNdPx,4yinTD9O3DebDIp s\_name,  
Supplier#000008742 HmPIQEzKCPEcTUL14,kKq count(\*) numwait  
Supplier#000008841 I 85Lu1sekbq2xrSIzm0 from  
Supplier#000008895 supplier,  
2cH4okfaLSZTTg8sKRbbJQxkmeFu2Esj lineitem l1,  
Supplier#000008967 2kwEHyMG orders,  
7FwozNImAUE6mH0hYtqYculJM nation  
Supplier#000008972 w2vF6 D5YZO3visPXsqVfLADTK where  
Supplier#000009032 qK,trB6Sdy4Dz1BRUFNy s\_suppkey = l1.l\_suppkey  
Supplier#000009147 rOAUryHxpZ9eOvx and o\_orderkey = l1.l\_orderkey  
Supplier#000009252 F7cZaPUHwh1 and o\_orderstatus = 'F'  
ZKyj3xmAVWC1XdP ue1p5m,i and l1.l\_receiptdate > l1.l\_commitdate  
Supplier#000009278 RqYTzgxj93CLX 0mcYfCENOfD and exists (  
Supplier#000009327 uoqMdf7e7Gj9dbQ53 select  
Supplier#000009430 igRqmneFt \*  
Supplier#000009567 r4Wfx4c3xsEAjcGj71HHZByornl from  
D9vrztXlv4 lineitem l2  
Supplier#000009601 51m637bO,Rw5DnHWFUvLacRx9 where  
Supplier#000009709 rRnCbHYgDgl9PZYnyWKVYSUW0vKg l2.l\_orderkey = l1.l\_orderkey  
Supplier#000009753 wLhVEcRmd7PkJF4FBnGK7Z and l2.l\_suppkey <> l1.l\_suppkey  
Supplier#000009796 z,y4Idmr15DOvPUqYG )  
Supplier#000009799 4wNjXGa4OKW1 and not exists (  
Supplier#000009811 E3iuyq7UnZxU7oPZie2Gu6 select  
Supplier#000009812 \*  
APFRMy3lCbgFga53n5t9DxzFPQPgnjrGt32 from  
Supplier#000009862 rJzweWeN58 lineitem l3  
Supplier#000009868 ROjGgx5gvtkmnUUoeyy7v where  
Supplier#000009869 l3.l\_orderkey = l1.l\_orderkey  
ucLqxrzrpBTRMewGSM29t0rNTM30glTu3Xgg3mKag and l3.l\_suppkey <> l1.l\_suppkey  
Supplier#000009899 7XdpaHRzr1t,UQFZE and l3.l\_receiptdate > l3.l\_commitdate  
Supplier#000009974 )  
7wJ,J5DKcxSU4KplcQLpbcAvB5AsvKT and s\_nationkey = n\_nationkey  
and n\_name = 'SAUDI ARABIA'  
group by  
s\_name  
order by

204 rows processed.

## Appendix D

```

numwait desc,
s_name)
where rownum <= 100

```

S_NAME	NUMWAIT
Supplier#000002829	20.00
Supplier#000005808	18.00
Supplier#000000262	17.00
Supplier#000000496	17.00
Supplier#000002160	17.00
Supplier#000002301	17.00
Supplier#000002540	17.00
Supplier#000003063	17.00
Supplier#000005178	17.00
Supplier#000008331	17.00
Supplier#000002005	16.00
Supplier#000002095	16.00
Supplier#000005799	16.00
Supplier#000005842	16.00
Supplier#000006450	16.00
Supplier#000006939	16.00
Supplier#000009200	16.00
Supplier#000009727	16.00
Supplier#000000486	15.00
Supplier#000000565	15.00
Supplier#000001046	15.00
Supplier#000001047	15.00
Supplier#000001161	15.00
Supplier#000001336	15.00
Supplier#000001435	15.00
Supplier#000003075	15.00
Supplier#000003335	15.00
Supplier#000005649	15.00
Supplier#000006027	15.00
Supplier#000006795	15.00
Supplier#000006800	15.00
Supplier#000006824	15.00
Supplier#000007131	15.00
Supplier#000007382	15.00
Supplier#000008913	15.00
Supplier#000009787	15.00
Supplier#000000633	14.00
Supplier#000001960	14.00
Supplier#000002323	14.00
Supplier#000002490	14.00
Supplier#000002993	14.00
Supplier#000003101	14.00
Supplier#000004489	14.00
Supplier#000005435	14.00
Supplier#000005583	14.00
Supplier#000005774	14.00
Supplier#000007579	14.00
Supplier#000008180	14.00
Supplier#000008695	14.00
Supplier#000009224	14.00
Supplier#000000357	13.00
Supplier#000000436	13.00
Supplier#000000610	13.00
Supplier#000000788	13.00

Supplier#000000889	13.00
Supplier#000001062	13.00
Supplier#000001498	13.00
Supplier#000002056	13.00
Supplier#000002312	13.00
Supplier#000002344	13.00
Supplier#000002596	13.00
Supplier#000002615	13.00
Supplier#000002978	13.00
Supplier#000003048	13.00
Supplier#000003234	13.00
Supplier#000003727	13.00
Supplier#000003806	13.00
Supplier#000004472	13.00
Supplier#000005236	13.00
Supplier#000005906	13.00
Supplier#000006241	13.00
Supplier#000006326	13.00
Supplier#000006384	13.00
Supplier#000006394	13.00
Supplier#000006624	13.00
Supplier#000006629	13.00
Supplier#000006682	13.00
Supplier#000006737	13.00
Supplier#000006825	13.00
Supplier#000007021	13.00
Supplier#000007417	13.00
Supplier#000007497	13.00
Supplier#000007602	13.00
Supplier#000008134	13.00
Supplier#000008234	13.00
Supplier#000009435	13.00
Supplier#000009436	13.00
Supplier#000009564	13.00
Supplier#000009896	13.00
Supplier#000000379	12.00
Supplier#000000673	12.00
Supplier#000000762	12.00
Supplier#000000811	12.00
Supplier#000000821	12.00
Supplier#000001337	12.00
Supplier#000001916	12.00
Supplier#000001925	12.00
Supplier#000002039	12.00
Supplier#000002357	12.00
Supplier#000002483	12.00

100 rows processed.  
Query Processed in 7.07 seconds.

Ended Executing this Stream at Mon Sep 6 12:38:16 2004

Stream Started at 1094492289.02  
Stream Ended at 1094492296.08  
Stream Processed in 7.07 seconds

## Appendix D

7 rows processed.  
Query Processed in 1.36 seconds.

SQL statements processed: 1

### 22.log

Begin Execution at Mon Sep 6 12:38:16 2004

Ended Executing this Stream at Mon Sep 6 12:38:17 2004

-- using default substitutions

Stream Started at 1094492296.14  
Stream Ended at 1094492297.49  
Stream Processed in 1.36 seconds

```
select
centrycode,
count(*) as numcust,
sum(c_acctbal) as totacctbal
from
(
select
substr(c_phone, 1, 2) as centrycode,
c_acctbal
from
customer
where
substr(c_phone,1, 2) in
('13', '31', '23', '29', '30', '18', '17')
and c_acctbal > (
select
avg(c_acctbal)
from
customer
where
c_acctbal > 0.00
and substr(c_phone, 1, 2) in
('13', '31', '23', '29', '30', '18', '17')
)
and not exists (
select
*
from
orders
where
o_custkey = c_custkey
)
) custsale
group by
centrycode
order by
centrycode
```

SQL statements processed: 1

CENTRYCODE	NUMCUST	TOTACCTBAL
13	888.00	6737713.99
17	861.00	6460573.72
18	964.00	7236687.40
23	892.00	6701457.95
29	948.00	7158866.63
30	909.00	6808436.13
31	922.00	6806670.18

***Appendix E: Seed and Input Parameters***



## Appendix E

### Seed

0901042751

8 UNITED KINGDOM EUROPE SMALL PLATED  
TIN  
14 1996-12-01  
19 Brand#42 Brand#41 Brand#44 9 12  
24  
9 dark  
22 33 21 26 31 12 24 30  
1 97  
4 1996-10-01

### Stream 0

14 1996-08-01  
2 10 BRASS AMERICA  
9 floral  
20 thistle 1993-01-01 JORDAN  
6 1995-01-01 0.02 24  
17 Brand#54 MED DRUM  
18 314  
8 FRANCE EUROPE SMALL POLISHED COPPER  
21 ARGENTINA  
13 unusual accounts  
3 HOUSEHOLD 1995-03-08  
22 34 31 15 25 17 26 13  
16 Brand#25 ECONOMY BURNISHED 18 5  
3 28  
50 42 40 19  
4 1994-03-01  
11 SAUDI ARABIA 0.0000003333  
15 1995-01-01  
1 89  
10 1994-11-01  
19 Brand#35 Brand#13 Brand#55 4 11  
27  
5 EUROPE 1995-01-01  
7 ARGENTINA FRANCE  
12 TRUCK MAIL 1996-01-01

### Stream 2

6 1995-01-01 0.05 25  
17 Brand#53 JUMBO PACK  
14 1997-03-01  
16 Brand#45 MEDIUM BRUSHED 5 23 22  
6 1  
15 20 47  
19 Brand#44 Brand#34 Brand#43 4 13  
20  
10 1994-06-01  
9 chocolate  
2 35 COPPER AMERICA  
15 1995-05-01  
8 MOROCCO AFRICA SMALL ANODIZED TIN  
5 AFRICA 1995-01-01  
22 13 20 21 19 25 32 10  
12 REG AIR MAIL 1997-01-01  
7 IRAN MOROCCO  
13 unusual deposits  
18 313  
1 105  
4 1994-07-01  
20 rose 1995-01-01 CHINA  
3 FURNITURE 1995-03-10  
11 VIETNAM 0.0000003333  
21 IRAN

### Stream 1

21 CHINA  
3 AUTOMOBILE 1995-03-24  
18 312  
5 MIDDLE EAST 1995-01-01  
11 INDIA 0.0000003333  
7 CHINA UNITED KINGDOM  
6 1995-01-01 0.07 25  
20 ghost 1996-01-01 CANADA  
17 Brand#51 JUMBO BOX  
12 AIR MAIL 1996-01-01  
16 Brand#15 STANDARD POLISHED 27 12  
5 6  
37 34 44 13  
15 1997-08-01  
13 unusual deposits  
10 1993-09-01  
2 47 NICKEL EUROPE

### Stream 3

8 GERMANY EUROPE STANDARD POLISHED TIN  
5 AMERICA 1995-01-01  
4 1997-02-01  
6 1995-01-01 0.02 24  
17 Brand#55 JUMBO DRUM  
7 BRAZIL GERMANY  
1 113  
18 315  
22 15 23 19 33 26 14 32  
14 1997-06-01  
9 blush  
10 1993-03-01  
15 1997-11-01  
11 INDONESIA 0.0000003333

## Appendix E

20 coral 1993-01-01 INDIA  
2 23 STEEL MIDDLE EAST  
21 BRAZIL  
19 Brand#41 Brand#12 Brand#42 10 14  
27  
13 unusual deposits  
16 Brand#25 PROMO BURNISHED 3 10 6  
4 32  
19 12 27  
12 SHIP MAIL 1997-01-01  
3 MACHINERY 1995-03-27

3 MACHINERY 1995-03-29  
1 68  
2 48 NICKEL MIDDLE EAST  
5 EUROPE 1996-01-01  
8 MOZAMBIQUE AFRICA PROMO BRUSHED  
TIN  
20 antique 1995-01-01 JAPAN  
12 MAIL FOB 1997-01-01  
17 Brand#54 WRAP PACK  
10 1994-09-01  
9 wheat

### Stream 4

5 ASIA 1996-01-01  
21 SAUDI ARABIA  
14 1997-09-01  
19 Brand#53 Brand#55 Brand#32 5 15  
23  
15 1995-08-01  
17 Brand#52 WRAP BOX  
12 FOB SHIP 1995-01-01  
6 1996-01-01 0.08 25  
4 1994-11-01  
9 azure  
8 UNITED STATES AMERICA STANDARD  
BURNISHED TIN  
16 Brand#15 SMALL PLATED 48 12 1  
22 29  
11 18 47  
11 RUSSIA 0.0000003333  
2 11 BRASS AMERICA  
10 1993-12-01  
18 313  
1 60  
13 unusual deposits  
7 CHINA UNITED STATES  
22 12 31 15 16 26 33 11  
3 FURNITURE 1995-03-12  
20 navajo 1997-01-01 RUSSIA

### Stream 6

10 1993-07-01  
3 BUILDING 1995-03-14  
15 1995-11-01  
13 express packages  
6 1996-01-01 0.02 24  
8 INDIA ASIA PROMO PLATED NICKEL  
9 steel  
7 BRAZIL INDIA  
4 1995-03-01

### Stream 5

21 JAPAN  
15 1993-05-01  
4 1997-06-01  
6 1996-01-01 0.05 25  
7 IRAN MOZAMBIQUE  
16 Brand#45 LARGE BRUSHED 2 31 30  
3 36  
8 49 32  
19 Brand#51 Brand#33 Brand#31 10 16  
30  
18 314  
14 1997-12-01  
22 22 12 10 34 16 13 21  
11 INDONESIA 0.0000003333  
13 express deposits

## ***Appendix F: Benchmark Scripts***

## Appendix F

```
FROM PARTSUPP WHERE PS_PARTKEY =19763);
```

### dbtables.sql

```
set echo on
set numwidth 25
spool rdbtablest
SELECT COUNT(*) FROM LINEITEM;

SELECT * FROM LINEITEM
WHERE L_ORDERKEY IN
( 4, 26598, 148577, 387431, 56704, 517442, 600000)
AND L_LINENUMBER = 1
ORDER BY L_ORDERKEY;

SELECT * FROM REGION;

SELECT COUNT(*) FROM NATION;

SELECT * FROM NATION
WHERE N_NATIONKEY IN (3,10,14,20)
ORDER BY N_NATIONKEY;
SELECT COUNT(*) FROM ORDERS;
SELECT * FROM ORDERS
WHERE O_ORDERKEY IN ( 7, 44065, 287590, 411111,
483876, 599942 )
ORDER BY O_ORDERKEY;

SELECT COUNT(*) FROM PART;

SELECT * FROM PART
WHERE P_PARTKEY IN
(1,984,8743,9028,13876,17899,20000)
ORDER BY P_PARTKEY;

SELECT COUNT(*) FROM PARTSUPP;

SELECT* FROM PARTSUPP
WHERE PS_PARTKEY = 3398
AND PS_SUPPKEY = (SELECT MIN(PS_SUPPKEY)
FROM PARTSUPP WHERE PS_PARTKEY = 3398);

SELECT* FROM PARTSUPP
WHERE PS_PARTKEY =15873
AND PS_SUPPKEY = (SELECT MIN(PS_SUPPKEY)
FROM PARTSUPP WHERE PS_PARTKEY = 15873);

SELECT* FROM PARTSUPP
WHERE PS_PARTKEY = 11394
AND PS_SUPPKEY = (SELECT MIN(PS_SUPPKEY)
FROM PARTSUPP WHERE PS_PARTKEY = 11394);

SELECT* FROM PARTSUPP
WHERE PS_PARTKEY = 6743
AND PS_SUPPKEY = (SELECT MIN(PS_SUPPKEY)
FROM PARTSUPP WHERE PS_PARTKEY = 6743);

SELECT* FROM PARTSUPP
WHERE PS_PARTKEY = 19763
AND PS_SUPPKEY = (SELECT MIN(PS_SUPPKEY)
```

```
SELECT COUNT(*) FROM SUPPLIER;

SELECT * FROM SUPPLIER
WHERE S_SUPPKEY IN (83,265,492,784,901,1000)
ORDER BY S_SUPPKEY;

SELECT COUNT(*) FROM CUSTOMER;

DROP TABLE MINMAX;

CREATE TABLE MINMAX
(TNAME CHAR(15),
KEYMIN INTEGER,
KEYMAX INTEGER);

INSERT INTO MINMAX
SELECT
'LINEITEM_ORD',MIN(L_ORDERKEY),MAX(L_ORDER
KEY)
FROM LINEITEM ;

INSERT INTO MINMAX
SELECT
'LINEITEM_NBR',MIN(L_LINENUMBER),MAX(L_LINE
NUMBER)
FROM LINEITEM;

INSERT INTO MINMAX
SELECT
'ORDERTBL',MIN(O_ORDERKEY),MAX(O_ORDERKEY)
FROM ORDERS;

INSERT INTO MINMAX
SELECT
'CUSTOMER',MIN(C_CUSTKEY),MAX(C_CUSTKEY)
FROM CUSTOMER;

INSERT INTO MINMAX
SELECT 'PART',MIN(P_PARTKEY),MAX(P_PARTKEY)
FROM PART;

INSERT INTO MINMAX
SELECT
'SUPPLIER',MIN(S_SUPPKEY),MAX(S_SUPPKEY)
FROM SUPPLIER;

INSERT INTO MINMAX
SELECT
'PARTSUPP_PART',MIN(PS_PARTKEY),MAX(PS_PART
KEY)
FROM PARTSUPP;

INSERT INTO MINMAX
```

## Appendix F

```
SELECT
'PARTSUPP_SUPP',MIN(PS_SUPPKEY),MAX(PS_SUPPK
EY)
FROM PARTSUPP ;
```

```
INSERT INTO MINMAX
SELECT
'NATION',MIN(N_NATIONKEY),MAX(N_NATIONKEY)
FROM NATION;
```

```
INSERT INTO MINMAX
SELECT
'REGION',MIN(R_REGIONKEY),MAX(R_REGIONKEY)
FROM REGION;
```

```
SELECT * FROM MINMAX;
spool off
exit;
```

### dbinsert.sql

```
rem
rem
=====+
=====
rem FILENAME
rem   inserts.sql
rem DESCRIPTION
rem   Inserts duplicate rows with new key numbers and
rem   inserts rows with values beyond the TPC-D values.
rem
rem
=====
=====
rem
rem Usage:  sqlplus tpcc/tpcc @insert
rem
```

```
set pagesize 100
set termout on
set echo on
set timing on
spool rdbinsert
```

```
rem
=====
=====
rem Duplicates
rem
=====
=====
```

```
REM get timestamp
```

```
select to_char (sysdate, 'HH24:MI:SS') timestamp from dual;
```

```
drop table temp_part;
create table temp_part as
  select * from part
    where p_partkey = 1;
update temp_part
  set p_partkey = 2147483647;
insert into part
  (select * from temp_part);
select * from part
  where p_partkey = 2147483647
 or p_partkey = 1;
delete from part
  where p_partkey = 2147483647;
drop table temp_part;
commit;
```

```
drop table temp_supplier;
create table temp_supplier as
  select * from supplier
    where s_suppkey = 1;
update temp_supplier
  set s_suppkey = 2147483647;
insert into supplier
  (select * from temp_supplier);
select * from supplier
  where s_suppkey = 2147483647
 or s_suppkey = 1;
delete from supplier
  where s_suppkey = 2147483647;
drop table temp_supplier;
commit;
```

```
drop table temp_partsupp;
create table temp_partsupp as
  select * from partsupp
    where ps_partkey = 1
      and ps_suppkey = 2;
update temp_partsupp
  set ps_partkey = 2147483647,
    ps_suppkey = 2147483647;
insert into partsupp
  (select * from temp_partsupp);
select * from partsupp
  where (ps_partkey = 2147483647
 and ps_suppkey = 2147483647)
 or (ps_partkey = 1
 and ps_suppkey = 2);
delete from partsupp
  where ps_partkey = 2147483647
 and ps_suppkey = 2147483647;
drop table temp_partsupp;
commit;
```

```
drop table temp_customer;
create table temp_customer as
```

## Appendix F

```
select * from customer
  where c_custkey = 1;
update temp_customer
  set c_custkey = 2147483647;
insert into customer
  (select * from temp_customer);
select * from customer
  where c_custkey = 2147483647
 or c_custkey = 1;
delete from customer
  where c_custkey = 2147483647;
drop table temp_customer;
commit;

drop table temp_orders;
create table temp_orders as
  select * from orders
  where o_orderkey = (select min(o_orderkey) from
orders);
update temp_orders
  set o_orderkey = 2147483647;
insert into orders
  (select * from temp_orders);
select * from orders
  where o_orderkey = 2147483647
 or o_orderkey = (select min(o_orderkey) from
orders);
delete from orders
  where o_orderkey = 2147483647;
drop table temp_orders;
commit;

drop table temp_lineitem;
create table temp_lineitem as
  select * from lineitem
  where l_orderkey = (select min(o_orderkey) from
orders)
 and l_linenumber = 1;
update temp_lineitem
  set l_orderkey = 2147483647,
  l_partkey = 2147483647,
  l_suppkey = 2147483647,
  l_linenumber = -2147483646;
insert into lineitem
  (select * from temp_lineitem);
select * from lineitem
  where (l_orderkey = 2147483647
 and l_partkey = 2147483647
 and l_suppkey = 2147483647
 and l_linenumber = -2147483646)
 or (l_orderkey = (select min(o_orderkey) from
orders)
 and l_linenumber = 1);
delete from lineitem
  where l_orderkey = 2147483647
 and l_partkey = 2147483647
 and l_suppkey = 2147483647
 and l_linenumber = -2147483646;
drop table temp_lineitem;
```

```
commit;

drop table temp_nation;
create table temp_nation as
  select * from nation
  where n_nationkey = 1;
update temp_nation
  set n_nationkey = 2147483647;
insert into nation
  (select * from temp_nation);
select * from nation
  where n_nationkey = 2147483647
 or n_nationkey = 1;
delete from nation
  where n_nationkey = 2147483647;
drop table temp_nation;
commit;

drop table temp_region;
create table temp_region as
  select * from region
  where r_regionkey = 1;
update temp_region
  set r_regionkey = 2147483647;
insert into region
  (select * from temp_region);
select * from region
  where r_regionkey = 2147483647
 or r_regionkey = 1;
delete from region
  where r_regionkey = 2147483647;
drop table temp_region;
commit;

rem
=====
=====
rem Duplicates finished starting inserts for domain range
rem
=====
=====

REM get timestamp
select to_char (sysdate, 'HH24:MI:SS') timestamp from dual;

insert into supplier
  (s_suppkey, s_name, s_address, s_nationkey,
s_phone,
s_acctbal, s_comment)
values
(2147483647, 'NAME text .....25E',
'Address varchar .....30.....40E',
2147483647, 'This is phone E', 123456789012,
'Supplier comment field is 101 long no E');
select * from supplier
  where s_suppkey = 2147483647;
delete from supplier D
```

## Appendix F

```

where s_suppkey = 2147483647;
rem
=====
=====
insert into part
(p_partkey, p_name, p_mfgr, p_brand, p_type,
 p_size, p_container, p_retailprice, p_comment)
values
(2147483647, 'Pname text .....2.....3.....4....5E',
 'Pmfr text.....2....5E','Pbrand 10E',
 'Ptype varchar.....2....5E', 2147483646,
 'PcontainrE', 123456789012,
 'Part comment field 23E');
select * from part
  where p_partkey = 2147483647;
delete from part
  where p_partkey = 2147483647;
rem
=====
=====
insert into partsupp
(ps_partkey, ps_suppkey, ps_availqty, ps_supplycost,
 ps_comment)
values
(2147483647, 2147483647, -2147483646,
123456789012,
 'PS comment field is 199 long no E');
select * from partsupp
  where ps_partkey = 2147483647
    and ps_suppkey = 2147483647;
delete from partsupp
  where ps_partkey = 2147483647
    and ps_suppkey = 2147483647;
rem
=====
=====
insert into customer
(c_custkey, c_name, c_address, c_nationkey,
 c_phone, c_acctbal, c_mktsegment, c_comment)
values
(2147483647, 'Customer Name goes to 25E',
 'Customer Address goes here..3.....4E',
 2147483647, 'This is phone E', 123456789012,
 'ZMark segE', 'Customer comments fiels is 117 long
no E');
select * from customer
  where c_custkey = 2147483647;
delete from customer
  where c_custkey = 2147483647;
rem
=====
=====
insert into orders
(o_orderkey, o_custkey, o_orderstatus, o_totalprice,
 o_orderdate, o_orderpriority, o_clerk, o_shippriority,
 o_comment)
values
(2147483647, 2147483647, 'X', 123456789012,
TO_DATE('2005-12-30','YYYY-MM-DD'),

```

```

'Order Priority5E', 'Fixed text 15E', -2147483646,
'Order comments field is 79 no E');
select * from orders
  where o_orderkey = 2147483647
    and o_custkey = 2147483647;
delete from orders
  where o_orderkey = 2147483647
    and o_custkey = 2147483647;
rem
=====
=====
insert into lineitem
(l_orderkey, l_partkey, l_suppkey, l_linenummer,
 l_quantity, l_extendedprice, l_discount, l_tax,
 l_returnflag, l_linestatus, l_shipdate, l_commitdate,
 l_receiptdate, l_shipinstruct, l_shipmode,
 l_comment)
values
(2147483647,
 2147483647,
 2147483647,
-2147483646,
-123456789012,
-123456789012,
-123456789012,
-123456789012,
'Q',
'R',
TO_DATE('2005-12-30','YYYY-MM-DD'),
TO_DATE('2005-12-30','YYYY-MM-DD'),
TO_DATE('2005-12-30','YYYY-MM-DD'),
'Ship by camel .....5E',
'Ship ASAPE',
'Is this really what you wanted? 44 long....E');
select * from lineitem
  where l_orderkey = 2147483647
    and l_partkey = 2147483647
    and l_suppkey = 2147483647
    and l_linenummer = -2147483646;
delete from lineitem
  where l_orderkey = 2147483647
    and l_partkey = 2147483647
    and l_suppkey = 2147483647
    and l_linenummer = -2147483646;
rem
=====
=====
insert into nation
(n_nationkey, n_name, n_regionkey, n_comment)
values
(2147483647,
'Ze Republic d MakebelievE',
 2147483647,
'A nation comment for field size 152 no E');
select * from nation
  where n_nationkey = 2147483647
    and n_regionkey = 2147483647;
delete from nation
  where n_nationkey = 2147483647

```

## Appendix F

```
and n_regionkey = 2147483647;
rem
=====
=====
insert into region
  (r_regionkey, r_name, r_comment)
  values
  (2147483647,
   'Ze ends of the earth....E',
   'A reasonable comment would go herE');
select * from region
  where r_regionkey = 2147483647;
delete from region
  where r_regionkey = 2147483647;
rem
=====
=====

REM get timestamp
select to_char (sysdate, 'HH24:MI:SS') timestamp from dual;
rem
=====
=====

rem Done
rem
=====
=====

spool off;
exit;
```

### gen\_seed.sh

```
#!/bin/ksh

SEED_FILE=$1

#Generate the seed

echo "Setting the random number seed"

PSEED=`date +%m:%d:%H:%M:%S | sed -e 's://g'`

echo "Using ${PSEED} as seed0"

echo ${PSEED} > $SEED_FILE

echo "Done setting the random number seed"
```

### runTPCHall.beforeload

```
#!/bin/ksh

. $KIT_DIR/env

ECHO=echo

sqlplus=$ORACLE_HOME/bin/sqlplus

GTIME=${KIT_DIR}/utils/gtime

RUN_ID_FILE=${KIT_DIR}/audit/r_id

if [ ! -f $RUN_ID_FILE ]

then

  echo "0" > $RUN_ID_FILE

fi

RUN_ID=`cat $RUN_ID_FILE`

RUN_ID=`expr $RUN_ID + 1`

echo $RUN_ID > $RUN_ID_FILE

OUT_DIR=${KIT_DIR}/audit/tests/${RUN_ID}

if [ ! -d $OUT_DIR ]

then

  mkdir $OUT_DIR

fi

SCRIPT_LOG_FILE=${OUT_DIR}/main.out
RDB_TABLES=${OUT_DIR}/rdtablest
```



## Appendix F

```
FIRST_TEN=${OUT_DIR}/firstten
LD1DBCRE=${OUT_DIR}/Ld1dbcre
LD2SCTSO=${OUT_DIR}/Ld2sctso
LD3DAPOP=${OUT_DIR}/Ld3dapop

2shut abort
2asmshut

echo Start TPC-H Benchmark SEQUENCE NUMBER:
$RUN_ID > $SCRIPT_LOG_FILE
echo >> $SCRIPT_LOG_FILE
echo "Starting a new Oracle log file:
$ORACLE_HOME/rdbms/log/alert_${ORACLE_SID}
.log" >> $SCRIPT_LOG_FILE
echo >> $SCRIPT_LOG_FILE

mv
$ORACLE_HOME/rdbms/log/alert_${ORACLE_SID}.log
$ORACLE_HOME/rdbms/log/alert_${ORACLE_SID}.log.preAudit.$RUN_ID
touch
$ORACLE_HOME/rdbms/log/alert_${ORACLE_SID}.log

echo "Start: load database `date`" >> $SCRIPT_LOG_FILE
asmstart
build_dg_AUDIT2.sh >> $LD1DBCRE
dbcre_AUDIT2.sh >> $LD1DBCRE
tscre_AUDIT2.sh >> $LD2SCTSO
tshut
asmshut
2asmstart
2start
STIME=`SGTIME`
echo "Start: timed load portion `date`" >>
$SCRIPT_LOG_FILE
dapop_AUDIT2.sh >> $LD3DAPOP
$KIT_DIR/audit/gen_seed.sh $KIT_DIR/audit/seed
echo Generated seed: `cat $KIT_DIR/audit/seed` >>
$SCRIPT_LOG_FILE
2shut
2asmshut
2asmstart
2start
2shut
2asmshut
echo "End: timed load portion `date`" >>
$SCRIPT_LOG_FILE

exit

2asmstart >> $SCRIPT_LOG_FILE
2start >> $SCRIPT_LOG_FILE
ckpnt.sh
echo "Start: dbtables.sql and count.sql" >>
$SCRIPT_LOG_FILE
$sqlplus ${DATABASE_USER} @$KIT_DIR/audit/dbtables
> ${RDB_TABLES} 2>&1
$sqlplus ${DATABASE_USER} @$KIT_DIR/audit/firstten
> ${FIRST_TEN} 2>&1
```

```
echo "End: dbtables.sql and count.sql `date`" >>
$SCRIPT_LOG_FILE

runTPCHpt ${SCALE_FACTOR} 1 ${RUN_ID}

#2shut > $SCRIPT_LOG_FILE
#2start >> $SCRIPT_LOG_FILE
#ckpnt.sh
runTPCHpt ${SCALE_FACTOR} 2 ${RUN_ID}

sleep 600
2shut >> $SCRIPT_LOG_FILE

cp $ORACLE_HOME/rdbms/log/alert_${ORACLE_SID}.log
$OUT_DIR

echo "End TPC-H Benchmark SEQUENCE NUMBER:
$RUN_ID `date`" >> $SCRIPT_LOG_FILE

runTPCHall.afterload
#!/bin/ksh
. $KIT_DIR/env

ECHO=echo

sqlplus=$ORACLE_HOME/bin/sqlplus
GTIME=${KIT_DIR}/utils/gtime

RUN_ID_FILE=${KIT_DIR}/audit/r_id

if [ ! -f $RUN_ID_FILE ]
then
echo "0" > $RUN_ID_FILE
fi

RUN_ID=`cat $RUN_ID_FILE`
#RUN_ID=`expr $RUN_ID + 1`
echo $RUN_ID > $RUN_ID_FILE

OUT_DIR=${KIT_DIR}/audit/tests/${RUN_ID}
if [ ! -d $OUT_DIR ]
then
mkdir $OUT_DIR
fi
SCRIPT_LOG_FILE=${OUT_DIR}/main.out
RDB_TABLES=${OUT_DIR}/rdbtablest
FIRST_TEN=${OUT_DIR}/firstten
LD1DBCRE=${OUT_DIR}/Ld1dbcre
LD2SCTSO=${OUT_DIR}/Ld2sctso
LD3DAPOP=${OUT_DIR}/Ld3dapop

#echo Start TPC-H Benchmark SEQUENCE NUMBER:
$RUN_ID > $SCRIPT_LOG_FILE
```

## Appendix F

```
#echo >> $SCRIPT_LOG_FILE
#echo "Starting a new Oracle log file:
$ORACLE_HOME/rdbms/log/alert_${ORACLE_SID}
}.log" >> $SCRIPT_LOG_FILE
#echo >> $SCRIPT_LOG_FILE
#
#mv
$ORACLE_HOME/rdbms/log/alert_${ORACLE_SID}.log
$ORACLE_HOME/rdbms/log/alert_
${ORACLE_SID}.log.preAudit.$RUN_ID
#touch
$ORACLE_HOME/rdbms/log/alert_${ORACLE_SID}.log

#echo "Start: load database `date`" >> $SCRIPT_LOG_FILE
#asmstart
#build_dg_AUDIT2.sh >> $LD1DBCRE
#dbcre_AUDIT2.sh >> $LD1DBCRE
#tscre_AUDIT2.sh >> $LD2SCTSO
#tshut
#asmshut
#2asmstart
#2start
#STIME=`$GTIME`
#echo "Start: timed load portion `date`" >>
$SCRIPT_LOG_FILE
#dapop_AUDIT2.sh >> $LD3DAPOP
#$KIT_DIR/audit/gen_seed.sh $KIT_DIR/audit/seed
#echo Generated seed: `cat $KIT_DIR/audit/seed` >>
$SCRIPT_LOG_FILE
#2shut
#2asmshut
#echo "End: timed load portion `date`" >>
$SCRIPT_LOG_FILE

#2asmstart >> $SCRIPT_LOG_FILE
#2start >> $SCRIPT_LOG_FILE
#ckpnt.sh

#echo "Start: dbtables.sql and count.sql" >>
$SCRIPT_LOG_FILE
#sqlplus ${DATABASE_USER}
@${KIT_DIR}/audit/dbtables > ${RDB_TABLES} 2>&1
#sqlplus ${DATABASE_USER} @${KIT_DIR}/audit/firstten
> ${FIRST_TEN} 2>&1
#echo "End: dbtables.sql and count.sql `date`" >>
$SCRIPT_LOG_FILE

#runTPCHpt ${SCALE_FACTOR} 1 ${RUN_ID}
#2shut >> $SCRIPT_LOG_FILE
#2asmshut >> ${SCRIPT_LOG_FILE}
#exit
2asmstart >> ${SCRIPT_LOG_FILE}
2start >> ${SCRIPT_LOG_FILE}
ckpnt.sh
runTPCHpt ${SCALE_FACTOR} 2 ${RUN_ID}

sleep 600
2shut >> ${SCRIPT_LOG_FILE}
```

```
2asmshut >> ${SCRIPT_LOG_FILE}

cp $ORACLE_HOME/rdbms/log/alert_${ORACLE_SID}.log
$OUT_DIR

echo "End TPC-H Benchmark SEQUENCE NUMBER:
$RUN_ID `date`" >> $SCRIPT_LOG_FILE

runuf1.sh
#!/bin/ksh
#
# $Header: runuf1.sh 25-oct-2001.15:56:04 mpoess Exp $
#
# runuf1.sh
#
# Copyright (c) 1999, 2001, Oracle Corporation. All rights
reserved.
#
# NAME
# runuf1.sh - <one-line expansion of the name>
#
# DESCRIPTION
# runuf1.sh -l [<path name for reports>] -u [<uid/passwd>]
# -p [<program>] <run_id> <scale factor> <pair
number>
# <parallelism>
# USAGE
# To execute UF1.
#
# NOTES
# <other useful comments, qualifications, etc.>
#
# MODIFIED (MM/DD/YY)
# mpoess 10/25/01 - change default directory for update
sets
# mpoess 10/17/01 - add support for external tables
# mpoess 08/15/99 - Creation
# mpoess 08/15/99 - Creation
#
#
. $KIT_DIR/env
O=${ORACLE_HOME}
UPDATE_DIR=${KIT_DIR}/update
SCRIPT_DIR=${UPDATE_DIR}/scripts
UTILS_DIR=${KIT_DIR}/utils
LOG_DIR=${UPDATE_DIR}/log
GTIME=${UTILS_DIR}/gtime
SF=${SCALE_FACTOR}
PAR_HINT=16

LOGPATH=
PASSWD=${DATABASE_USER}

if [ $# -lt 1 ];
then
echo runuf1.sh setnum
exit 1
fi
SETNUM=$1
```

## Appendix F

```
i=1
PID=""

# perform the update function 1

START=`$GTIME`

# first create the temp tables

sqlplus /NOLOG << !

connect $PASSWD;
set timing on
set serveroutput on
set echo on

drop directory data_dir;
create directory data_dir as '/ff1/';

drop table temp_l_et;
create table temp_l_et(
  l_orderkey      number ,
  l_partkey       number ,
  l_suppkey       number ,
  l_linenumbers   number ,
  l_quantity      number ,
  l_extendedprice number ,
  l_discount      number ,
  l_tax           number ,
  l_returnflag    char(1) ,
  l_linestatus    char(1) ,
  l_shipdate      date ,
  l_commitdate    date ,
  l_receiptdate   date ,
  l_shipinstruct  char(25) ,
  l_shipmode      char(10) ,
  l_comment       varchar(44)
)
organization external (
type ORACLE_LOADER
default directory data_dir
access parameters
(
  records delimited by newline
  nobadfile
  nologfile
  fields terminated by '|'
  missing field values are null
)
location (
'orders.tbl.u${SETNUM}'
))
reject limit unlimited;
alter table temp_l_et parallel ${PAR_HINT};
alter table temp_o_et parallel ${PAR_HINT};

alter session force parallel dml parallel (degree
${PAR_HINT});
alter session set isolation_level = serializable;
alter session set optimizer_index_cost_adj = 10;

insert into orders (
select
  o_orderdate      ,
  o_orderkey       ,
  o_custkey        ,
  o_orderpriority  ,
  o_shippriority   ,
  o_clerk          ,
  o_orderstatus    ,
  o_totalprice     ,
  o_comment
from temp_o_et);

insert into lineitem (
select
  l_shipdate      ,
  l_orderkey      ,
  l_discount      ,
  l_extendedprice ,
  l_suppkey       ,
  l_quantity      ,
  l_returnflag    ,
  l_partkey       ,
  l_linestatus    ,
  l_tax           ,
  l_commitdate    ,
  l_receiptdate   ,
  l_shipmode      ,
```

## Appendix F

```
l_linenumber      ,
l_shipinstruct    ,
l_comment
from temp_l_et);
commit;
drop table temp_l_et;
drop table temp_o_et;

exit;
!

END=`$GTIME`

# Done

echo ""
echo "Update Function 1 Set $SETNUM done!"
echo "Elapsed Time is `echo $END - $START | bc`"
echo ""

runuf2.sh
#!/bin/ksh
#
# $Header: runuf2.sh 25-oct-2001.15:56:05 mpoess Exp $
#
# runuf2.sh
#
# Copyright (c) 1999, 2001, Oracle Corporation. All rights
reserved.
#
# NAME
# runuf2.sh - <one-line expansion of the name>
#
# DESCRIPTION
# runuf2.sh [-u <uid/passwd to login>] [-p <program>]
<run_id>
# <scale factor> <pair number> <parallelism>
# USAGE
# To execute UF2.
#
# NOTES
# <other useful comments, qualifications, etc.>
#
# MODIFIED (MM/DD/YY)
# mpoess 10/25/01 - change default directory for update
sets
# mpoess 10/17/01 - add support for external tables
# mpoess 08/15/99 - Creation
# mpoess 08/15/99 - Creation
#
. $KIT_DIR/env
UPDATE_DIR=${KIT_DIR}/update
SCRIPT_DIR=${UPDATE_DIR}/scripts
UTILS_DIR=${KIT_DIR}/utils
GTIME=${UTILS_DIR}/gtime
LOG_DIR=${UPDATE_DIR}/log
PAR_HINT=16
SF=${SCALE_FACTOR}
```

```
PASSWD=${DATABASE_USER}

if [ $# -lt 1 ]
then
usage
exit 1
fi

SETNUM=$1

i=1
PID=""

START=`$GTIME`
# first create the temp tables

sqlplus /NOLOG << !

connect $PASSWD;
set timing on
set serveroutput on
set echo on

drop directory data_dir;
create directory data_dir as '/ff1/';

drop table temp_okey_et;
drop table temp_okey;

create table temp_okey_et(
t_orderkey number
)
organization external (
type ORACLE_LOADER
default directory data_dir
access parameters
(
records delimited by newline
nobadfile
nologfile
fields terminated by '|'
missing field values are null
)
location (
'delete.${SETNUM}'))
reject limit unlimited;

alter table temp_okey_et parallel ${PAR_HINT};

create table temp_okey parallel ${PAR_HINT} nologging as
select * from temp_okey
_et;

create unique index i_temp_okey on temp_okey (t_orderkey)
parallel ${PAR_HINT}
nologging compute statistics;

analyze table temp_okey estimate statistics sample 2 percent;
```

## Appendix F

```
alter session force parallel dml parallel ${PAR_HINT};
alter session set isolation_level=serializable;
alter session set optimizer_index_cost_adj = 10;
delete from (select /*+ use_nl(o) */ o.rowid from orders o,
temp_okey t where o.
o_orderkey = t.t_orderkey order by 1);

delete from (select /*+ use_nl(l) */ l.rowid from lineitem
l,temp_okey t where l
.l_orderkey = t.t_orderkey order by 1);

commit;
drop table temp_okey;
drop table temp_okey_et;
exit;
!
```

END=`\$GTIME`

# Done

```
echo ""
echo "Update Function 2 Set $SETNUM done!"
echo "Elapsed Time is `echo $END - $START | bc`"
echo ""
```

**qexecpl.c**

```
#ifdef RCSID
static char *RCSid =
"$Header: qexecpl.c 17-oct-2001.09:29:47 mpoess Exp $ ";
#endif /* RCSID */

/* Copyright (c) 1999, 2001, Oracle Corporation. All rights
reserved. */

/*

NAME
    qexecpl.c - <one-line expansion of the name>

DESCRIPTION
    SQL Execution Engine, Oracle v8, OCI version

PRIVATE FUNCTION(S)
    <list of static functions defined in .c file - with one-line
descriptions>

MODIFIED (MM/DD/YY)
    mpoess 10/17/01 - add serialization level in SQLinit
    mpoess 02/22/01 - add linux changes
    mpoess 08/05/99 - make compile
    mpoess 11/13/98 - fix pdll statement
    pswong 02/19/97 - migrating to version 8
    pswong 04/02/96 - more polishing
    pswong 03/25/96 - polish up
    pswong 03/06/96 - created

*/
```

```
#include <stdio.h>
#include <string.h>
#include <setjmp.h>
#include <sys/param.h>
#include <errno.h>
#include <math.h>
#include <string.h>
#include <sys/types.h>
#include <time.h>
#include <stdlib.h>

#include "qexecpl.h"

/* Function Prototypes */

extern double gettimeofday();

/* function prototypes from gen.c */

int get_statement();

/* Declare error handling functions */

void sql_error();

/* Other prototypes */

int define_output_variables();
void process_select_list();
void usage();
void SQLinit();
void SQLexec();
void SQLexit();
void *memalloc();
void print_header();
void print_rows();
int OFEN();
void remove_newline();

char logname[UNAME_LEN]; /* username/passwd combo */
char *passwd;

double tr_start = 0.0; /* query start time */
double tr_end = 0.0; /* query end time */

double s_tr_start = 0.0; /* statement start time */
double s_tr_end = 0.0; /* statement end time */

/* For our purpose of timing, we will treat comments as
delimiters */
/* for queries. Thus, we will collect query timings whenever
we */
/* encounter a comment (of course not for the first comment
in a */
/* file). */

int end_flag = 0; /* flag to indicate that we have reached
*/
```

## Appendix F

```

/* the end of a query */

int stmt_cnt = 0; /* Number of statements processed.
*/
int qry_cnt = 0; /* Number of query processed. */

double product = 1.0; /* cumulative product of query times
*/
int rows_ret = 0; /* the number of rows fetched */
int num_sel_list = 0; /* the number of select list item */

long num_to_fetch = -1; /* Number of rows to fetch. -1
means fetch all */

slist slist[MAX_SEL_LIST]; /* Array for describing Select
List */
dlist *dlist[MAX_SEL_LIST]; /* Array of ptrs for Defining
Select List */

char stmt[SQL_LEN]; /* The SQL statement or comment
line. */
char qn[4]; /* Number of the query being executed
*/
char qnp[4]; /* Number of the previous query
executed */
char cmnt[5000]; /* Buffer to save the comment.
*/
#ifdef LINUX
FILE *qtemp; /* fd for query template */
FILE *logfile; /* log and report files */
FILE *rep;
#else
FILE *qtemp = stdin; /* fd for query template */
FILE *logfile = stdout; /* log and report files */
FILE *rep = stdout;
#endif
void *defbuf; /* Buffer pointer for ODEFIN */
int deflen = 0; /* Size of data type for ODEFIN */
int deftype = 1; /* Oracle type number for ODEFIN
*/

int pfmem = PFMEMSIZE; /* Memory to prefetch rows
*/

time_t tim; /* To get wall clock time */

/* OCI handles */

OCIEnv *tpcenv = NULL;
OCIServer *tpcsrv = NULL;
OCIError *errhp = NULL;
OCISvcCtx *tpcsvc = NULL;
OCISession *tpcusr = NULL;
OCISmt *curq = NULL;
OCISmt *cur_dml = NULL;
OCISmt *cur_ddl = NULL;
OCIParm *tpcpar = NULL;

```

```

sword status = OCI_SUCCESS; /* OCI return value */

```

```

/* usage: prints the usage of the program */

```

```

void usage() {

    fprintf(stderr, "\nUsage: qexec username/password [q<path
name for query template file>]\n");
    fprintf(stderr, "          [l<path name for log>] [r<path
name for reports>]\n\n");
    fprintf(stderr, "Options:\n");
    fprintf(stderr, "q<path for query>      : full path name for the
query template file.\n");
    fprintf(stderr, "          (default is stdin)\n");
    fprintf(stderr, "l<path name for log>      : full path name for
log files\n");
    fprintf(stderr, "          (default is stdout)\n");
    fprintf(stderr, "r<path name for reports> : full path name for
reports\n");
    fprintf(stderr, "          (default is stdout)\n");
    exit(-1);
}

```

```

/* type: 0 if environment handle is passed, 1 if error handle is
passwd */

```

```

void sql_error(errhp, status, type)
    OCIError *errhp;
    sword status;
    sword type;
{
    char msg[2048];
    ub4 errcode;
    ub4 msglen;
    int i, j;

    switch(status) {
    case OCI_SUCCESS_WITH_INFO:
        fprintf(stderr, "Error: Statement returned with info.\n");
        if (type)
            (void)
OCIErrorGet(errhp, 1, NULL, (sb4*)&errcode, (text*)msg,
                2048, OCI_HTYPE_ERROR);
        else
            (void)
OCIErrorGet(errhp, 1, NULL, (sb4*)&errcode, (text*)msg,
                2048, OCI_HTYPE_ENV);
        fprintf(stderr, "%s\n", msg);
        break;
    case OCI_ERROR:
        fprintf(stderr, "Error: OCI call error.\n");
        if (type)
            (void)
OCIErrorGet(errhp, 1, NULL, (sb4*)&errcode, (text*)msg,
                2048, OCI_HTYPE_ERROR);
        else
            (void)
OCIErrorGet(errhp, 1, NULL, (sb4*)&errcode, (text*)msg,

```

## Appendix F

```

                2048,OCI_HTYPE_ENV);
    fprintf(stderr,"%s\n",msg);
    break;
case OCI_INVALID_HANDLE:
    fprintf(stderr, "Error: Invalid Handle.\n");
    if (type)
        (void)
OCIErrorGet(errhp,1,NULL,(sb4*)&errcode,(text*)msg,
            2048,OCI_HTYPE_ERROR);
    else
        (void)
OCIErrorGet(errhp,1,NULL,(sb4*)&errcode,(text*)msg,
            2048,OCI_HTYPE_ENV);
    fprintf(stderr,"%s\n",msg);
    break;
}

/* Rollback just in case */

(void) OCITransRollback(tpcsvc,errhp,OCI_DEFAULT);

fprintf(stderr, "Exiting Oracle...\n");
fflush(stderr);

SQLexit();

exit(1);
}

#ifdef LINUX
int main(argc,argv)
#else
void main(argc,argv)
#endif
    int argc;
    char *argv[];
{

    int i,pos,pos2;
    int retcode; /* Return code for get_statement */
#ifdef LINUX
    logfile=fopen("/dev/stdout","w");
    qtemp=fopen("/dev/stdin","rw");
    rep=fopen("/dev/stdout","w");
#endif
    /* Initialize some variables */

    if ((argc > 5) || (argc < 2)) {
        usage();
    }

    /* argv[1] -- User and Password for Database */

    strcpy(logname, argv[1]);

    /* Process optional parameters */

    argc -= 1;
    argv += 1;

```

```

while(--argc) {
    ++argv;
    switch(argv[0][0]) {
    case 'q':
        if ((qtemp = fopen(++(argv[0]),"r")) == NULL) {
            fprintf(stderr,"Unable to open file '%s'\n", argv[0]);
            fprintf(stderr,"%s: %s\n", argv[0], strerror(errno));
            exit(-1);
        }
        break;
    case 'r':
        if ((rep = fopen(++(argv[0]),"a")) == NULL) {
            fprintf(stderr,"Unable to open file '%s'\n", argv[0]);
            fprintf(stderr,"%s: %s\n", argv[0], strerror(errno));
            exit(-1);
        }
        break;
    case 'l':
        if ((logfile = fopen(++(argv[0]),"a")) == NULL) {
            fprintf(stderr,"Unable to open file '%s'\n", argv[0]);
            fprintf(stderr,"%s: %s\n", argv[0], strerror(errno));
            exit(-1);
        }
        break;
    default:
        fprintf(stderr,"Invalid Option: %c\n", argv[0][0]);
        usage();
        break;
    }
}

/* Do some initialization and establish connection with the
database */

SQLinit();

/* May want to add some triggering mechanism here */

time(&tim);
fprintf(logfile, "Begin Execution at %s\n\n", ctime(&tim));
fprintf(rep, "Begin Executing this Stream at %s\n\n",
ctime(&tim));
/* Get the next statement and start processing it */

while ((retcode = get_statement()) > 0) {

    switch (retcode) {

        /* If this is a comment, skips it */
    case COMMENT:
        /*if (end_flag) {
            end_flag = 0; /* /* reset query end flag */
            /* save the comment so that we can print it out later
on */
            /* strcpy(cmnt, stmt);
            break;
        } */
        if (stmt[3]=='@') {

```

## Appendix F

```

pos=4;
strcpy(qnp,qn);
while (stmt[pos] != ')') {
    pos++;
}
pos2=0;
pos++;
while (stmt[pos] != '!') {
    /*printf ("qn %d %c \n",pos2,stmt[pos]);*/
    qn[pos2]=stmt[pos];
    pos2++;
    pos++;
}
qn[pos2] = 0;
/* printf("found a new query: %s\n",qn); */
}
/* save the comment so that we can print it out later on */
strcat(cmnt, stmt);
break;

/* if this is a set_row_fetch command */
case SET_FETCHROW:
    fprintf(logfile,"Setting the number of rows to fetch to:
%d\n",
        num_to_fetch);
    break;

/* if this is a SQL statement */
case SQL_STMT:

    /* Executes the query */
    SQLexec();

    stmt_cnt++;
    qry_cnt++;
    fflush(rep);
    fflush(logfile);
    /*
    fprintf(logfile,"nStatement Started at %.2fn", s_tr_start);
    fprintf(logfile,"Statement Ended at %.2fn", s_tr_end);

    fprintf(logfile,"Statement Processed in %.2f seconds.\n",
        (s_tr_end - s_tr_start));
    fprintf(rep, "Query %s: Execution Time: %.2f started %.2f
ended %.2fn",
        qn,(s_tr_end - s_tr_start)s_tr_start,s_tr_end);
    fflush(rep);
    fflush(logfile);*/
    break;

/* Should never reach here */
default:
    fprintf(stderr, "Invalid statement type!!\n");
    SQLexit();
    break;
}
}

/* Get Timing for the last query */
tr_end = gettimeofday();

fprintf(logfile,"Query Processed in %.2f
seconds.\n\n",(tr_end - s_tr_start));

/* print comments for this query that we have saved */
/* fprintf(logfile, "%s\n", cmnt); */

/* fprintf(rep, "Query %s : Execution time %.2fn",
qn,(tr_end - s_tr_start));*/
fprintf(rep, "Query %s: Execution Time: %.2f started %.2f
ended %.2fn",
        qn,(tr_end - s_tr_start),s_tr_start,tr_end);

time(&tim);
fprintf(logfile, "\nEnded Executing this Stream at %s\n",
ctime(&tim));
fprintf(logfile, "\nStream Started at %.2fn", tr_start);
fprintf(logfile, "Stream Ended at %.2fn", tr_end);
fprintf(logfile, "Stream Processed in %.2f
seconds\n\n",(tr_end - tr_start));

fprintf(rep, "\nEnded Executing this Stream at %s\n",
ctime(&tim));
fprintf(rep, "\nStream Started at %.2fn", tr_start);
fprintf(rep, "Stream Ended at %.2fn", tr_end);
fprintf(rep, "Stream Processed in %.2f seconds\n\n",
        (tr_end - tr_start));

fprintf(logfile, "\nSQL statements processed: %d\n",
stmt_cnt);
/*fprintf(logfile, "Queries processed: %d\n", qry_cnt);*/

fflush(rep);
fflush(logfile);

/* Close the query template file */
fclose(qtemp);

/* Disconnect from ORACLE. */
SQLexit();
exit(0);
}

/* SQLinit(): Perform initialization tasks. */
/* Logs on to Oracle, opens some files and open a
cursor for */
/* later use. */

void SQLinit() {

    int i;

```



## Appendix F

```

/* preallocate MAX_PREALLOC members of the dlist array
*/
/* initializes others to NULL so that we can determine who
to free later */

for (i=0; i<MAX_SEL_LIST; i++) {
    if (i < MAX_PREALLOC) {
        dlist[i] = (dlttype *) memalloc (sizeof(dlttype));
        dlist[i]->defhdl = NULL;
    }
    /* OCIhalloc(curq,&(dlist[i]-
>defhdl),OCI_HTYPE_DEFINE); */
    }
    else
        dlist[i] = NULL;
    }

/* Connect to ORACLE. Program will call sql_error()
*/
/* if an error occurs in connecting to the default database. */

(void) OCIInitialize(OCI_DEFAULT,(dvoid *)0,0,0,0);

if((status=OCIEnvInit((OCIEnv
**) &tpcenv,OCI_DEFAULT,0,(dvoid **)0)) !=
OCI_SUCCESS)
    sql_error(tpcenv, status, 0);

OCIhalloc(tpcenv,&errhp,OCI_HTYPE_ERROR);
OCIhalloc(tpcenv,&curq,OCI_HTYPE_STMT);
OCIhalloc(tpcenv,&cur_dml,OCI_HTYPE_STMT);
OCIhalloc(tpcenv,&cur_ddl,OCI_HTYPE_STMT);
OCIhalloc(tpcenv,&tpcsvc,OCI_HTYPE_SVCCTX);
OCIhalloc(tpcenv,&tpcsrv,OCI_HTYPE_SERVER);
OCIhalloc(tpcenv,&tpcusr,OCI_HTYPE_SESSION);

/* get username and password */

passwd = strchr(logname, '/');
*passwd = '\0';
passwd++;

if ((status = OCIServerAttach(tpcsrv,errhp,(text
*)0,0,OCI_DEFAULT)) != OCI_SUCCESS)
    sql_error(errhp,status,1);

OCIaset(tpcsvc,OCI_HTYPE_SVCCTX,tpcsrv,0,OCI_ATTR
_SERVER,errhp);

OCIaset(tpcusr,OCI_HTYPE_SESSION,logname,strlen(logna
me),OCI_ATTR_USERNAME,
errhp);

OCIaset(tpcusr,OCI_HTYPE_SESSION,passwd,strlen(passw
d),OCI_ATTR_PASSWORD,
errhp);

if((status = OCISessionBegin(tpcsvc, errhp, tpcusr,
OCI_CRED_RDBMS,
OCI_DEFAULT)) !=
OCI_SUCCESS)
    sql_error(errhp,status,1);

OCIaset(tpcsvc,OCI_HTYPE_SVCCTX,tpcusr,0,OCI_ATTR
_SESSION,errhp);
/*
if ((status=OCILogon((OCIEnv *)tpcenv,(OCIError
*)errhp,(OCISvcCtx *)tpcsvc,
(text *)logname, strlen(logname), (text
*)passwd,
strlen(passwd), (text *) 0, 0)) !=
OCI_SUCCESS)
    sql_error(errhp, status, 1);
*/
printf("\nConnected to ORACLE as user: %s\n\n", logname);
}

/* SQLexec() Executes the SQL statement.
*/
/* Parse the SQL statement. */
/* If DDL or DML statements, execute right away.
*/
/* Else describe and define select list outputs, */
/* execute and fetch results. */

void SQLexec()
{
    int i;
    ub2 stmttyp = OCI_STMT_SELECT; /* default is a
SELECT statement */

    /* Clause 5.3.6.2: QI(i,s) is the time between the first
character */
    /* of this query text is submitted and the first */
    /* character of the next query text is submitted. */

    if (qry_cnt) {
        time(&tim);
        s_tr_end = gettime();
        fprintf(logfile,"Query Processed in %.2f seconds.\n\n",
(s_tr_end - s_tr_start));

        /* print comments for this query that we have saved */
        /* fprintf(logfile, "%s\n", cmnt); */

        /*fprintf(rep, "Query %s : Execution time %.2f\n",
qnp,(s_tr_end - s_tr_start));*/
        fprintf(rep, "Query %s: Execution Time: %.2f started %.2f
ended %.2f\n",
qnp,(s_tr_end - s_tr_start),s_tr_start,s_tr_end);
    }
}

```

## Appendix F

```

/* Let's fflush stuff so that we can see what's going on */
/* Fix for Q15 */
fflush(logfile);
fflush(rep);

strcpy(qnp,qn);

fflush(logfile);
fflush(rep);
}
else
    tr_start = gettime();

s_tr_start = gettime();

/* prepare the statement */

if ((status = OCISstmtPrepare(curq, errhp, (text*) stmt, (ub4)
strlen(stmt),
                                OCI_NTV_SYNTAX,
OCI_DEFAULT)) != OCI_SUCCESS)
    sql_error(errhp,status,1);

/* Prints the query text and comment to the logfile */

fprintf(logfile, "\n%s\n", cmnt);
cmnt[0]=0;
fprintf(logfile, "\n%s\n", stmt);

/* if this is a DDL or DML statement, execute it right away
*/
/* only worries about SELECT statements right now, cannot
*/
/* execute a stored PL/SQL procedure in this version */

OCIaget(curq,OCI_HTYPE_STMT,&stmttyp,NULL,OCI_AT
TR_STMT_TYPE,errhp);

if (stmttyp != OCI_STMT_SELECT) {
    OCIsexec(tpcsvc,curq,errhp,1);
    return;
}

/* otherwise, this is a select statement */
/* Describe and define output variables */

/* first let's execute it to get the select-list definition */

OCIaset(curq, OCI_HTYPE_STMT, &pfmem, 0,
OCI_ATTR_PREFETCH_MEMORY, errhp);

OCIsexec(tpcsvc,curq,errhp,0);

num_sel_list = define_output_variables();

/* Executes the query and fetches the rows */
(void) process_select_list(num_sel_list);

/* Need to get the number of rows fetched first */
/* since the following statments will screw it up */

OCIaget(curq,OCI_HTYPE_STMT,&rows_ret,NULL,OCI_A
TTR_ROW_COUNT,errhp);

/* To control memory usage, let's free up the extra dlist
entries */
/* that we have allocated. */

i=MAX_PREALLOC;
while(dlist[i] != NULL) {
    free(dlist[i]);
    dlist[i++] = NULL;
}

/* reset set_fetchrows */

num_to_fetch = -1;
}

void SQLexit() {

    int i;

    OCILogoff(tpcsvc,errhp);
    OCIhfree(tpcenv,OCI_HTYPE_STMT);
    OCIhfree(tpcsvc,OCI_HTYPE_SVCCTX);
    OCIhfree(tpcsrv,OCI_HTYPE_SERVER);
    OCIhfree(tpcusr,OCI_HTYPE_SESSION);

    /* free all memory */

    for (i=0; i<MAX_SEL_LIST; i++) {
        if (dlist[i] != NULL) {
            free(dlist[i]);
        }
    }

    /* Flush all output */

    fflush(rep);
    fflush(logfile);
}

/* define_output_variables(): Describe and define select-list
items for */
/* a query statement. */
/* Returns the number of select-list items */
/* for this query. */

int define_output_variables()

```

## Appendix F

```

{
    int i;
    int retflag = 0;

    for (i=0; i<MAX_SEL_LIST; i++) {

        slist[i].buflen = MAX_COLNAME_SIZE;

        if (OCIParamGet(curq, OCI_HTYPE_STMT, errhp, (dvoid
**) &tpcpar,
                POS(i)) != OCI_SUCCESS)
            break;

        /* dsize and nullok fields of dlist not used */

        OCIaget(tpcpar, OCI_DTYPE_PARAM, &(slist[i].dbsize),
                NULL, OCI_ATTR_DATA_SIZE, errhp);
        OCIaget(tpcpar, OCI_DTYPE_PARAM, &(slist[i].dbtype),
                NULL, OCI_ATTR_DATA_TYPE, errhp);
        OCIaget(tpcpar, OCI_DTYPE_PARAM, &(slist[i].buf),
                &(slist[i].buflen), OCI_ATTR_NAME, errhp);
        OCIaget(tpcpar, OCI_DTYPE_PARAM,
&(slist[i].precision),
                NULL, OCI_ATTR_PRECISION, errhp);
        OCIaget(tpcpar, OCI_DTYPE_PARAM, &(slist[i].scale),
                NULL, OCI_ATTR_SCALE, errhp);

        /* For formatting purpose, remove trailing blanks in select-
list name. */

        /*
        if (slist[i].buflen < MAX_COLNAME_SIZE)
            (slist[i].buf)[slist[i].buflen] = '\0';
        */

        /* Well, we need to allocate for entries for dlist */

        if (i >= MAX_PREALLOC) {
            dlist[i] = (dtype *) memalloc(sizeof(dtype));
            dlist[i]->defhdl = NULL;
        }

        /* Let's check the sizes and types for this select list item */

        switch (slist[i].dbtype) {

        case OCI_TYPECODE_NUMBER:

            /* The odescr will not give a good estimate to the scale if
            */
            /* no scale was given in the Oracle table definition. */

#ifdef HAVE_SCALE
            if (slist[i].scale != 0) {
                defbuf = (double *) dlist[i]->fbuf;
                deflen = FLT;
                deftype = OCI_TYPECODE_DOUBLE;
                slist[i].dbtype = OCI_TYPECODE_DOUBLE;
            } else {
                defbuf = (int *) dlist[i]->ibuf;
                deflen = INT;
                deftype = OCI_TYPECODE_INTEGER;
                slist[i].dbtype = OCI_TYPECODE_INTEGER;
            }
#else
            defbuf = (double *) dlist[i]->fbuf;
            deflen = FLT;
            deftype = OCI_TYPECODE_FLOAT;
            slist[i].dbtype = OCI_TYPECODE_FLOAT;
#endif /* HAVE_SCALE */

            break;

        default:

            /* default is character string */

            defbuf = (char **) dlist[i]->sbuf;
            deflen = MAX_STR_LEN;
            deftype = SQLT_STR;
            /* deftype = OCI_TYPECODE_CHAR; */
            break;
        }

        /* Define the column */

        if ((status=OCIDefineByPos(curq,&(dlist[i]-
>defhdl),errhp,POS(i),
                defbuf,deflen,deftype,NULL,
                dlist[i]-
>rlen,NULL,OCI_DEFAULT))!=OCI_SUCCESS)
            sql_error(errhp,status,1);
        }
        return i;
    }

    /* process_select_list(): Fetch rows from a query. */

    void process_select_list(num)
        int num; /* number of select list items */
    {
        int i,j;
        int ntf;
        int num_so_far;
        sword stats = OCI_SUCCESS;

        /* Print the headers for the query execution result */

        print_header(num);

        /* See if we need to limit the rows to fetch */

        ntf = (num_to_fetch >= 0) ? num_to_fetch : MAX_ARRAY;

        /* Fetch the rows and print them out */
    }
}

```

## Appendix F

```

if ((ntf > MAX_ARRAY) || (num_to_fetch == -1)) {

    stats = OCISstmtFetch(curq, errhp, MAX_ARRAY,
OCI_FETCH_NEXT, OCI_DEFAULT);

OCIaget(curq,OCI_HTYPE_STMT,&rows_ret,NULL,OCI_A
TTR_ROW_COUNT,errhp);

    print_rows(num,rows_ret);

    /* To avoid 1022 from OFEN */
    /* More rows to fetch... */

    if (stats != OCI_NO_DATA) {
        if (num_to_fetch == -1) {
            while ((stats =
OCIISstmtFetch(curq,errhp,MAX_ARRAY,OCI_FETCH_NEX
T,
OCI_DEFAULT)) ==
OCI_SUCCESS) {
OCIaget(curq,OCI_HTYPE_STMT,&num_so_far,NULL,
OCI_ATTR_ROW_COUNT,errhp);
    print_rows(num,(num_so_far-rows_ret));
    rows_ret = num_so_far;
    }
    /* Print the final rows */
    OCIaget(curq,OCI_HTYPE_STMT,&num_so_far,N
ULL,
OCI_ATTR_ROW_COUNT,errhp);
    print_rows(num,(num_so_far-rows_ret));
    rows_ret = num_so_far;
    } else {
        ntf -= MAX_ARRAY;

        while ((stats = OCISstmtFetch(curq,errhp,
((ntf>MAX_ARRAY)
? MAX_ARRAY:ntf),
OCI_FETCH_NEXT,
OCI_DEFAULT)) ==
OCI_SUCCESS) {
            ntf -= MAX_ARRAY;

OCIaget(curq,OCI_HTYPE_STMT,&num_so_far,NULL,
OCI_ATTR_ROW_COUNT,errhp);
    print_rows(num,(num_so_far-rows_ret));
    rows_ret = num_so_far;
    if (ntf <= 0) break;
    }
    OCIaget(curq,OCI_HTYPE_STMT,&num_so_far,N
ULL,
OCI_ATTR_ROW_COUNT,errhp);
    print_rows(num,(num_so_far-rows_ret));
    rows_ret = num_so_far;
    }
    } else {

```

```

OCIISstmtFetch(curq, errhp, ntf, OCI_FETCH_NEXT,
OCI_DEFAULT);

OCIaget(curq,OCI_HTYPE_STMT,&rows_ret,NULL,OCI_A
TTR_ROW_COUNT,errhp);
    print_rows(num,rows_ret);
    }

    fprintf(logfile, "\n\n%d %s processed.\n", rows_ret,
rows_ret == 1 ? "row" : "rows");
}

int get_statement()
{
    char line[128];
    char *pos, *str;

    /* Reset statement buffer */

    stmt[0] = '\0';

    while (fgets(line, 127, qtemp) != NULL) {

        /* skip blank lines */
        if (line[0] == '\n')
            continue;

        /* remove blanks */

        str = line;

        while (*str == ' ') str++;

        /* Let's get the line together first */

        strcat(stmt, str);

        /* if this is a comment line */
        if ((str[0] == '-') && (str[1] == '-'))
            return COMMENT;

        /* see if this is a set_fetchrows line */
        if (strncmp(str, "set_fetchrows", 13) == 0) {
            pos = strchr(str, ',');
            *pos = '\0';
            pos = strchr(str, '=');
            num_to_fetch = atol(++pos);
            return SET_FETCHROW;
        }

        /* if this is the end of the current statement */
        if ((pos = strchr(stmt, ';')) != NULL) {
            *pos = '\0';
            return SQL_STMT;
        }
    }
}

```

## Appendix F

```

return END_OF_FILE;
}

/* memalloc(): Allocates memory, exit program if we have a
problem. */

void *memalloc(size)
    int size;
{
    void *tmp;

    if ((tmp = (void *) malloc(size)) == NULL) {
        fprintf(stderr, "Error in malloc\n");
        SQLexit();
        return NULL; /* should never reach here */
    } else {
        return tmp;
    }
}

void print_header(nsel)
    int nsel; /* Number of select list items */
{
    int i, diff;
    char colname[MAX_COLNAME_SIZE];
    int len = 0; /* Running column length */
    int cwid = 0;

    fprintf(logfile, "\n");

    for (i=0; i<nsel; i++) {

        /* extract the column name */

        strncpy((char *)colname, (char *)slist[i].buf, slist[i].buflen);
        colname[slist[i].buflen] = '\0';

        /* format the output a little */

        cwid = MAX(slist[i].dbsize, slist[i].buflen);

        /* do a little bit of formatting */

        if (cwid > 80) {
            fprintf(logfile, "\n");
            len = 0;
        } else if ((len += cwid) > 80) {
            fprintf(logfile, "\n");
            len = cwid;
        }
#ifdef FORMAT1
        if ((slist[i].dbtype == INT_TYPE) || (slist[i].dbtype ==
FLT_TYPE))
            fprintf(logfile, "%*s ", cwid, slist[i].buf);
            else /* string type */
                fprintf(logfile, "%*s ", -cwid, slist[i].buf);
#else
            fprintf(logfile, "%*s ", -cwid, colname);
#endif /* FORMAT1 */
        }

        fprintf(logfile, "\n");
    }

void print_rows(ncol, nrow)
    int ncol;
    int nrow;
{
    int i, j;
    int len;
    int diff;
    int cwid;

    for (i=0; i<nrow; i++) {

        len = 0;

        for (j=0; j<ncol; j++) {

            cwid = MAX(slist[j].dbsize, slist[j].buflen);

            /* do a little bit of formatting */

            if (cwid > 80) {
                fprintf(logfile, "\n");
                len = 0;
            } else if ((len += cwid) > 80) {
                fprintf(logfile, "\n");
                len = cwid;
            }

            switch(slist[j].dbtype) {
                case INT_TYPE:
#ifdef HAVE_SCALE
                    fprintf(logfile, "%*ld", cwid, (dlist[j]-
>ibuf)[i]);
                    break;
#endif /* HAVE_SCALE */
                case FLT_TYPE:
#ifdef FORMAT1
                    fprintf(logfile, "%*.2f ", cwid, (dlist[j]->fbuf)[i]);
                #else
                    fprintf(logfile, "%*.2f ", -cwid, (dlist[j]->fbuf)[i]);
                #endif /* FORMAT1 */
                break;
                default:
                    fprintf(logfile, "%*s ", -(cwid), (dlist[j]->sbuf)[i]);
                    break;
            }
        }
    }
    fprintf(logfile, "\n");
}

```

## Appendix F

```

}
}

/* remove_newline(): Remove newline character from str. */

void remove_newline(str)
    char *str;
{
    char *p;

    while ((p = strchr(str, '\n')) != NULL)
        *p = ' ';
}

qexecpl.h
/*
 * $Header: qexecpl.h 13-nov-2001.17:52:35 mpoess Exp $
 */

/* Copyright (c) 1999, 2001, Oracle Corporation. All rights
reserved. */

/* NOTE: See 'header_template.doc' in the 'doc' dve under the
'forms'
    directory for the header file template that includes
instructions.
*/

/*
    NAME
        qexecpl.h

    DESCRIPTION
        SQL statement execution front-end header file.

    PUBLIC FUNCTION(S)
        <list of external functions declared/defined - with one-line
descriptions>

    PRIVATE FUNCTION(S)
        <list of static functions defined in .c file - with one-line
descriptions>

    EXAMPLES
    NOTES
        <other useful comments, qualifications, etc.>

    MODIFIED (MM/DD/YY)
    mpoess 11/13/01 - change DOP to 84 for DML and DDL
    mpoess 02/22/01 - add linux changes
    mpoess 08/05/99 - make compile
    mpoess 07/15/99 - Creation
    mpoess 07/15/99 - Creation

*/

/*
# ifndef S_ORACLE
# include <s.h>
# endif
*/
# ifndef QSTREAMPL_H
# define QSTREAMPL_H

# include <stdio.h>
# include <string.h>
# include <sys/param.h>
# include <sys/types.h>
# include <time.h>
# include <errno.h>
# include <math.h>

# include <oratypes.h>

# include <oratypes.h>

# ifndef OCIDFN
# include <ocidfn.h>
# endif /* OCIDFN */

# ifndef OCI_ORACLE
# include <oci.h>
# endif /* OCI_ORACLE */
/*
# ifdef __STDC__
# include <ociapr.h>
# else
# include <ocikpr.h>
# endif /* __STDC__ */

/* some basic definitions */
# define UNAME_LEN 64
# define MAX_FILE_PATH_LEN 128

# ifndef TRUE
# define TRUE 1
# endif /* TRUE */

# ifndef FALSE
# define FALSE 1
# endif /* FALSE */
# ifndef LINUX
# define MAX(x,y) ((x >= y) ? x : y)
# define MIN(x,y) ((x <= y) ? x : y)
# endif
/* defines and typedefs for parsing */

# define CRT_TBL 1
# define INS_STMT 3
# define SEL_STMT 4
# define UPD_STMT 5
# define DRP_VIEW 7
# define DRP_TBL 8
# define DEL_STMT 9
# define CRT_VIEW 10

```

## Appendix F

```

/* defines and typedefs for query description */

#define MAX_COLNAME_SIZE 32 /* Maximum length of
Column name */
#define MAX_SEL_LIST 16 /* Maximum items on a
select list */

#define END_OF_LIST 1007 /* Error code when we reach
the end of the */
/* select list. */

/* types for describe */

#define CHAR_TYPE 1
#define NUM_TYPE 2
#define INT_TYPE 3
#define FLT_TYPE 4
#define STR_TYPE 5
#define DATE_TYPE 12

#define NUMWIDTH 16 /* Width of the numeric fields
*/

#define POS(i) (i+1) /* The position is 1..n instead */
#define IND(i) (i-1) /* of 0..n-1 as in an array. */

typedef struct des
{
    ub2 dbsize;
    ub4 buflen;
    /* sb2 dsize; */
    sb4 scale;
    /* sb2 nullok; */
    OCITextCode dbtype;
    /* text buf[MAX_COLNAME_SIZE]; */
    text *buf;
    ub1 precision;
} sltype;

/* defines and typedefs for query select list definition */

#define MAX_ARRAY 50 /* Maximum array size for
array fetch */
#define PFMEMSIZE 65536 /* Memory size of prefetch
buffer */

#define MAX_STR_LEN 256 /* Maximum size for string
variables */
#define MAX_PREALLOC 8 /* Maximum number of
preallocated select list */
/* definitions. */

#define INT sizeof(long)
#define STR sizeof(char)
#define FLT sizeof(double)
#define FLTP (double *)
#define INTP (long *)
#define STRP (char **)

typedef struct def
{
    long ibuf[MAX_ARRAY];
    double fbuf[MAX_ARRAY];
    char sbuf[MAX_ARRAY][MAX_STR_LEN];
    ub2 rlen[MAX_ARRAY]; /* return length */
} dltype;

extern int errno;

#define SQL_LEN 2048

#ifndef NULL
#define NULL 0
#endif

#ifndef NULLP
#define NULLP (void *)NULL
#endif /* NULLP */
#ifndef DISCARD
#define DISCARD (void)
#endif

#ifndef sword
#define sword int
#endif

#ifndef ub1
#define ub1 unsigned char
#endif

#define NA -1 /* ANSI SQL NULL */
#define VER7 2
#define NOT_SERIALIZABLE 8177 /* ORA-08177:
transaction not serializable */

#define ADR(object) ((ub1 *)&(object))
#define SIZ(object) ((sword)sizeof(object))
#define SID(sid) ((sid == -1) ? 0 : sid)

/* For get_statement */

#define END_OF_FILE -1
#define COMMENT 1
#define SQL_STMT 2
#define SET_FETCHROW 3

#define OCIhalloc(envh,hndl,htyp) \
    if((status=OCIHandleAlloc((dvoid *)envh,(dvoid **)hndl,htyp,0,(dvoid **)0))! \
    =OCI_SUCCESS) \
        sql_error(envh,status,0); \
    else \
        DISCARD 0

#define OCIhfree(hndl,htyp) \

```

## Appendix F

```
if((status=OCIHandleFree((dvoid *)hndl,htyp))==
OCI_SUCCESS) \
    fprintf(stderr, "Error freeing handle of type %d\n", htyp)
```

```
#define OCIaget(hndl,htyp,attp,size,atyp,errh) \
    if((status=OCIAttrGet((dvoid *)hndl,htyp,(dvoid
*)attp,(dvoid *)size,atyp,er
rh)) != OCI_SUCCESS) \
        sql_error(errh,status,1); \
    else \
        DISCARD 0
```

```
#define OCIaset(hndl,htyp,attp,size,atyp,errh) \
    if((status=OCIAttrSet((dvoid *)hndl,htyp,(dvoid
*)attp,size,atyp,errh)) != O
CI_SUCCESS) \
        sql_error(errh,status,1); \
    else \
        DISCARD 0
```

```
#define OCIsexec(svch,stmh,errh,iter) \
```

```
if((status=OCISmtExecute(svch,stmh,errh,iter,0,NULL,NUL
L,OCI_DEFAULT)) != O
CI_SUCCESS) \
        sql_error(errh,status,1); \
    else \
        DISCARD 0
```

```
#define ISOTXT "alter session set isolation_level =
serializable"
#define PDMLTXT "alter session force parallel dml parallel
(degree 84)"
#define PDDLTX "alter session force parallel ddl parallel
(degree 84)"
```

```
#endif /* QSTREAMPL_H */
```

### 2asmshut

```
#!/bin/ksh
. $FRAME_PATH/env
export ORACLE_SID=$ASM_SID
if [ "$1" = "abort" ]; then
for i in $SECONDARY_NODES
do
ssh $i -n $KIT_DIR/rasmshuta
done
sqlplus << !
connect / as sysdba
shutdown abort
exit
!
else
for i in $SECONDARY_NODES
do
ssh $i -n $KIT_DIR/rasmshut
done
sqlplus << !
```

126

```
connect / as sysdba
shutdown immediate
exit
```

!

```
fi
```

### 2asmstart

```
#!/bin/ksh
. $FRAME_PATH/env
export ORACLE_SID=$ASM_SID
sqlplus /NOLOG << EOF
!date
set timing on
connect / as sysdba
startup pfile=$ORACLE_HOME/dbs/init${ASM_SID}.ora
!date
exit
EOF
```

```
for i in $SECONDARY_NODES
do
ssh $i -n $KIT_DIR/rasmstart
done
```

### 2shut

```
#!/bin/ksh
. $FRAME_PATH/env
if [ "$1" = "abort" ]; then
for i in $SECONDARY_NODES
do
ssh $i -n /mnt/sdb2/home/oracle/frame/bin/tshut
done
sqlplus << !
connect / as sysdba
shutdown abort
exit
!
else
for i in $SECONDARY_NODES
do
ssh $i -n /mnt/sdb2/home/oracle/frame/bin/tshut abort
done
sqlplus << !
connect / as sysdba
shutdown immediate
exit
!
fi
```

### 2start

```
#!/bin/ksh
. $FRAME_PATH/env
tstart
```



## Appendix F

```
for i in $SECONDARY_NODES
do
ssh $i -n /mnt/sdb2/home/oracle/frame/bin/tstart
done

tshut
#!/bin/ksh
#
# $Header: tshut.sh 08-aug-99.18:06:22 mpoess Exp $
#
# tshut.sh
#
# Copyright (c) Oracle Corporation 1999. All Rights
Reserved.
#
# NAME
#   tshut.sh
#
# DESCRIPTION
#   shuts down a database
#
# NOTES
#   <other useful comments, qualifications, etc.>
#
# MODIFIED (MM/DD/YY)
#   mpoess 08/08/99 - Creation
#   mpoess 08/08/99 - Creation
#
#!/bin/ksh
```

```
if [ "$1" = "abort" ]; then
sqlplus /NOLOG<< !
connect / as sysdba
shutdown abort
exit
!
else
sqlplus /NOLOG<< !
connect / as sysdba
shutdown
exit
!
fi
```

```
tstart
#!/bin/ksh
#
# $Header: tstart.sh 08-aug-99.18:05:50 mpoess Exp $
#
# tstart.sh
#
# Copyright (c) Oracle Corporation 1999. All Rights
Reserved.
#
# NAME
#   tstart.sh
#
# DESCRIPTION
```

```
#   starts a database with a specific init.ora or uses the
default.
#
# NOTES
#   <other useful comments, qualifications, etc.>
#
# MODIFIED (MM/DD/YY)
#   mpoess 08/08/99 - Creation
#   mpoess 08/08/99 - Creation
#
#!/bin/ksh
```

```
DIR=`pwd`
cd $ORACLE_HOME/dbs
```

```
if [ "$1" != "" ]; then
  PFILE="pfile=$ORACLE_HOME/dbs/$1.ora"
else
```

```
  PFILE="pfile=$ORACLE_HOME/dbs/init_${ORACLE_SID}.o
ra"
fi
```

## ***Appendix G: Price Quotations***

# Appendix G

GreatCables.com: Category 5E CrossOver Cables - Microsoft Internet Explorer

File Edit View Favorites Tools Help

Address <http://www.greatcables.com/dept.asp?mcsid=B59VXMTGXVX9PWVXNSTPQ9K9B1T7AX7&dept%5Fid=218>

Back Forward Stop Refresh Home Search Favorites History Mail Print Edit

**GreatCables.com** Connections made simple Search  GO

Home Networking Sharing Solutions Home Theater Premise Wiring Cables

USB, Printer, Firewire, SCSI, Monitor, Keyboard & More

■ your list | ■ shopping cart | ■ check out | ■ your account | ■ help

Shop Online or Call 1-262-650-2222 Wednesday, September 08, 2004

Welcome

Login Here...

Catalog Quick Order  GO

Enter Item Code

Choose a dept/product

[Cables & Adapters](#) | [Category 5e & 6 Patch Cables](#) | [Category 5E CrossOver Cables](#)

### CrossOver Category 5/5e Patch Cables

GreatCables Category 5/5e Cross Over Cables directly link one computer to another on a Local Area Network (LAN). The RJ45 CAT 5e UTP crossover cable with molded strain relief is designed to connect Hub-to-Hub or PC-to-PC.

Order By: Price Low To High Page 1 of 4 : [ 1 ] 2 3 4

Product Info	Will Ship	Buy
<a href="#">Crossover Patch Cable RJ45 Category 5, 7 ft Gray</a> <b>Sale</b> \$1.75 Item Number: <a href="#">E5DD-C407</a>	Same Day	
<a href="#">PATCH CORD, CROSSOVER, RJ45, 1FT, ENHANCED CAT 5 BLACK</a> <b>Sale</b> \$2.98 Item Number: <a href="#">EEDDC401BK10R</a>	Same Day	

Start

C:\au... Adob... Trans... Gre... BBC... Com... Inbox... Com... dell... ftp://... Anot... Appe... powe... Powe...

9:01 AM

## Appendix G

-----Original Message-----

**From:** Vineet Buch [mailto:vineet.buch@oracle.com]

**Sent:** Thursday, August 19, 2004 2:30 PM

**To:** Nicholas\_Wakou@Dell.com

**Cc:** meikel.poess@oracle.com; ray.glasstone@oracle.com; mary.beth.pierantoni@oracle.com;

Mike\_Molloy@Dell.com

**Subject:** RE: Approval and Price quote for the Dell 2x4 TPC-H 300GB

Nicholas - Mary Beth's email to you will serve as the price quote and can be included in the FDR. Can you send me the full ES?

Thanks,

Vineet.

-----Original Message-----

**From:** MaryBeth Pierantoni [mailto:mary.beth.pierantoni@oracle.com]

**Sent:** Friday, August 06, 2004 6:23 PM

**To:** Wakou, Nicholas

**Cc:** Buch,Vineet; Meikel Poess; Ray Glasstone

**Subject:** Re: Pricing for the Dell 2x4 TPC-H 100GB

Hello Nicholas,

To follow is the Oracle pricing for Dell 2x4 cluster. Thank you.

Product	Quantity	Price	Extended Price
Oracle Database 10g Enterprise Edition, Named User Plus for 3 years	8	\$10,000	\$80,000
Real Application Clusters, Named User Plus for 3 years	8	\$5,000	\$40,000
Partitioning, Named User Plus for 3 years	8	\$2,500	\$20,000
Database Server Support Package for 3 years	3 yrs	\$4,000	\$12,000
Oracle Mandatory E-Business Discount			<\$22,800>
Total			\$129,200

Oracle pricing contact: MaryBeth Pierantoni,  
[mary.beth.pierantoni@oracle.com](mailto:mary.beth.pierantoni@oracle.com), 916-315-5081