

**TPC Benchmark<sup>®</sup> C  
Full Disclosure Report  
for  
Dell PowerEdge 6450  
Using  
Microsoft SQL Server 2000 8.0 Enterprise  
Edition  
and  
Microsoft Windows 2000 Advanced Server**

First Edition  
Submitted for Review  
OCT 23, 2000

## **First Printing, OCT 23, 2000**

Dell believes that the information included in this document is accurate as of the publication date. The information in this document is subject to change without notice. Furthermore, Dell is not responsible for any errors contained within this document.

The pricing information given in this FDR is accurate as of the publication date, OCT 23, 2000 and is generally available.

Benchmark results are highly dependent upon workload, specific application requirements, and system design and implementation. Relative system performance will vary as a result for these and other factors. Therefore, TPC Benchmark C should not be used as a substitute for a specific customer application benchmark when critical capacity planning and/or product evaluation decisions are contemplated.

All performance data contained in this report were obtained in a rigorously controlled environment. Actual performance experienced by a particular customer may vary due to differences in system layout and configuration, hardware and/or software revision levels, and background system activity. The content of this document is for informational purposes only.

Copyright 2000 Dell

All rights reserved. Permission is hereby granted to reproduce this document in whole or in part provided the copyright notice printed above is set forth in full text or on the title page of each item reproduced.

PowerEdge is a trademark of Dell.

Microsoft, Windows 2000 and SQL Server are registered trademarks of Microsoft Corporation.

TPC Benchmark, TPC-C and tpmC are registered trademarks of the Transaction Processing Performance Council.

Intel and Pentium are registered trademarks of Intel Corporation.

Other product names mentioned in this document may be trademarks and/or registered trademarks of their respective companies.

## Abstract

---

### Overview

This report documents the methodology and results of the TPC Benchmark™ C test conducted on Dell PowerEdge 6450. The tests were run in a client/server configuration using four PowerEdge 1300's as clients. The operating system used for the benchmark was Microsoft Windows 2000 Advanced Server on the database server and Microsoft Windows 2000 Server on the clients. The database was Microsoft SQL Server 2000 Enterprise Edition. Microsoft COM+ provided the database connection queues. All tests were done in compliance with Revision 3.5 of the Transaction Processing Council's TPC Benchmark™ C Standard Specification. Two standard TPC Benchmark™ C metrics, transactions per second (tpmC) and price per tpmC (\$/tpmC) are reported and referred to in this document. The results from the tests are summarized below.

Hardware	Software	Total System Cost	tpmC	\$/tpmC	Availability Date
Dell PowerEdge 6450	Microsoft Windows 2000 Advanced Server Windows 2000 Server SQL Server 2000 Enterprise Edition	\$210,862	30,231.37	\$6.98	Oct. 23, 2000

### Auditor

The results of the benchmark and test methodology used to produce the results were audited by Tom Sawyer of Performance Metrics and have fully met the TPC-C rev 3.5 specifications.

Additional copies of this Full Disclosure Report can be obtained from either the Transaction Processing Performance Council or Dell at the following address:

Transaction Processing Performance Council (TPC)  
c/o Shanley Public Relations  
777 North First Street, Suite 600  
San Jose, CA 95112, USA  
Phone: (408) 295-8894, fax 295-9768  
[www.tpc.org](http://www.tpc.org)

or

Dell  
1 Dell Drive  
Round Rock, TX 78682  
Attention: Mike Molloy



# PowerEdge 6450

Client/Server w/4 PE1300 Front Ends  
Repricing date  
Sept 26, 2001

TPC-C Rev 5.0  
Repricing  
Report Date  
Oct 23, 2000

Total System Cost		TPC-C Throughput	Price/Performance	Availability Date
<b>\$210,862</b>		<b>30,231.37 tpmC</b>	<b>\$6.98/ tpmC</b>	<b>Oct 23, 2000</b>
Processors	Database Manager	OS	Other Software	Number of Users
4 x Pentium® III Xeon™ Processors 700 MHz 2MB L2 Cache	Microsoft SQL Server 2000 Enterprise Edition	Microsoft Windows 2000 Advanced Server	Windows 2000 Server w/ COM+ Internet Information Server 5.0 Microsoft Visual C++	<b>24,320</b>

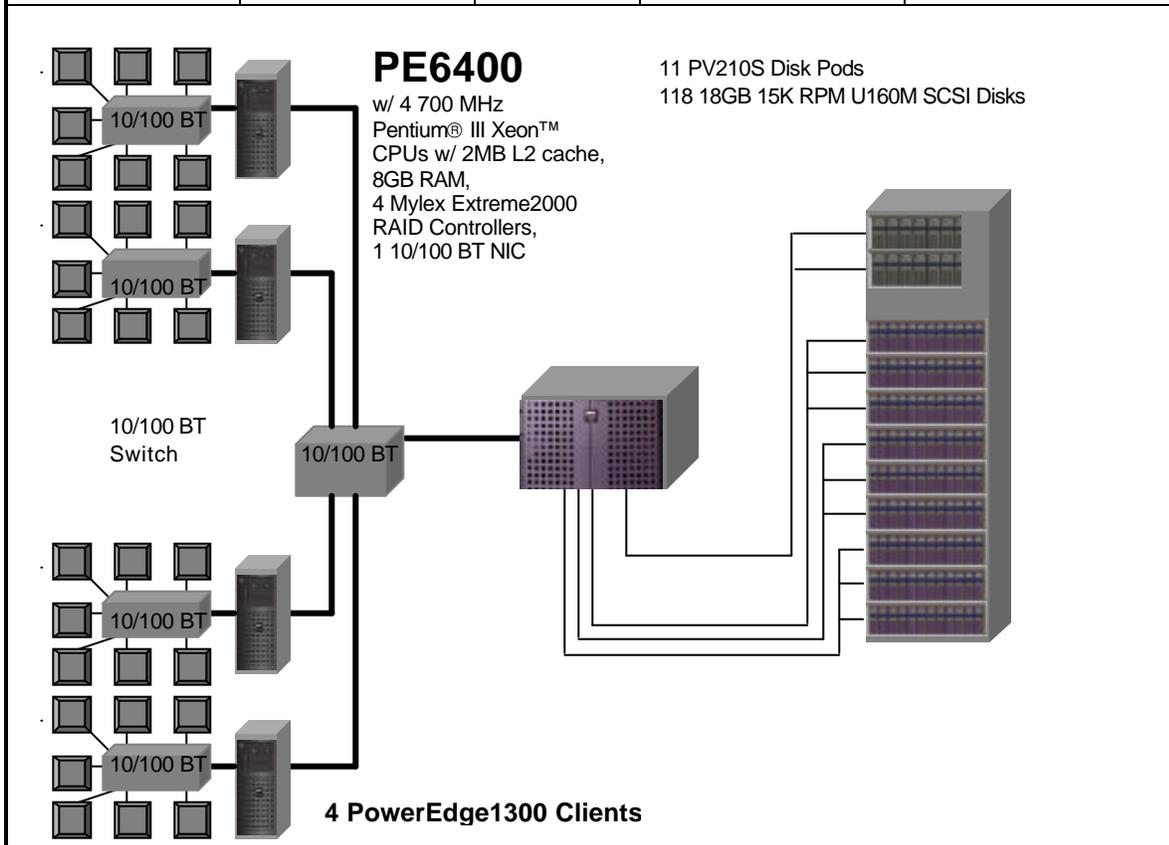

System Component	Server		Each Client	
Processors	4	Pentium® III Xeon™ @ 700MHz	1	Pentium® III w/ 512 KB L2
Cache		2MB		3 clients @ 600MHz, 1 @ 550
Memory		8192 MB		512 MB
Disk Controllers	4	Mylex ExtremeRAID 2000	1	Adaptec On-Board
	2	Adaptec On-Board		
Disk Drives	118	18 GB SCSI	1	9 GB
	1	9 GB SCSI		
Total Storage		1,985 GB		9 GB
Other	1	10/100 BT NIC	2	
	1	CD-ROM	1	
	1	Internal DAT		

Dell	PowerEdge 6450				TPC-C REV 5.0 EXECUTIVE SUMMARY PAGE 2 OF 2		
Upgrade Date: 19-March-01	Client/Server				Report Date: xx-Sept-01		
Description	Part Number	Third Party		Unit Price	Qty	Extended Price	3 yr. Maint. Price
		Brand	Pricing				
<b>Server Hardware</b>							
Dell PowerEdge 6400	220-0663			1	4,546	4,546	1,100
Pentium III Xeon 700 MHz / 2MB L2 - 4 processors	311-0834			1	7,845	7,845	-
8 GB RAM, 16 x 512MB DIMMS	311-4118			1	10,855	10,855	-
9 GB U160M SCSI 10K RPM Hard Drive	340-8088			1	249	249	-
Intel Pro 100+ NIC	430-1970	Intel		1	59	59	-
Tape Backup Unit	340-7420			1	999	999	-
Dell 15" Monitor	320-0960			1	149	149	-
Extreme RAID 2000 PCI SCSI 4 channel RAID controller***	E2000-4-32NB	Mylex		3	1,849	11,094	-
Back-UPS Office 650	001332	APC		1	167	2,170	539
						<b>Subtotal</b>	<b>1,639</b>
<b>PowerVault Disk Subsystem</b>							
PV210S, U3 SCSI, PS, Rack mount	220-4099, etc.			1	2,499	27,489	8,404
SCSI Cables	310-0313			1	49	539	-
18 GB U160M SMRT SCSI 15K RPM Hard Drive *	340-3232			1	499	58,882	-
42U Rack	220-0605			1	1,294	1,294	-
						<b>Subtotal</b>	<b>8,404</b>
<b>Server Software</b>							
SQL Server 2000 Ent Edition, Per processor licensing **		Microsoft		2	16,541	66,164	6,285
Windows 2000 Advanced Server, 25 Client Licenses **		Microsoft		2	2,399	2,399	-
						<b>Subtotal</b>	<b>6,285</b>
<b>Client Hardware</b>							
Dell PowerEdge 1300, 600 MHz Pentium III w/ 512KB L2****	220-2332			1	549	1,647	1,494
Dell PowerEdge 1300, 550 MHz Pentium III w/ 512KB L2****	220-2332			1	549	549	498
512MB RAM, 2 DIMMs	311-1108			1	490	1,960	-
9GB LVD SCSI Hard Drive,	340-1963			1	249	996	-
Ether Express PRO 100+ Ethernet Adapter	430-1970	Intel		1	59	472	-
Dell 15" Monitor	320-0960			1	149	596	-
						<b>Subtotal</b>	<b>1,992</b>
<b>Client Software</b>							
Windows 2000 Server, 5 Client Licenses **		Microsoft		2	738	2,952	-
Visual C++ Professional 6.0 Win32 **		Microsoft		2	549	549	-
						<b>Subtotal</b>	<b>-</b>
<b>User Connectivity</b>							
8 Port Ethernet Switch ***	CT2208D3	ArkPC		4	61	183	-
						<b>Subtotal</b>	<b>-</b>
						<b>Other Discounts</b>	<b>-</b>
						<b>Total</b>	<b>18,320</b>
Notes: * Maint. included in PowerVault 210S disk pod or PV650F/630F fibre channel disk pod ** All Microsoft maintenance is covered by the maintenance costs of Microsoft SQL Server *** 10% or minimum 2 spares are added in place of onsite service (products have a five year return-to-vendor warranty) Pricing: 1 - Dell 2 - Microsoft 3 - Mylex 4 - ArkPC 5 - MicroBarn **** Substituted with PE1400SC/933Mhz/P3 /256KB L2 <b>Audited by Tom Sawyer, Performance Metrics Inc.</b>						<b>Three-Year Cost of Ownership: \$210,861</b>  <b>tpmC Rating: 30231.00</b>  <b>\$/tpmC: 6.98</b>	
<i>Prices used in TPC benchmarks reflect the actual prices a customer would pay for a one-time purchase of the stated components. Individually negotiated discounts are not permitted. Special prices based on assumptions about past or future purchases are not permitted. All discounts reflect standard pricing policies for the listed components. For complete details, see the pricing sections of the TPC benchmark specifications. If you find that the stated prices are not available according to these items, please inform the TPC at pricing@tpc.org.</i> <i>according to these items, please inform the TPC at pricing@tpc.org.</i>							

<b>MQTh</b> , computed Maximum Qualified Throughput				30,231.37
				tpmC
% throughput difference, reported & reproducibility runs				0.47%
<b>Response Times</b> (in seconds)	Average	90th	Max	
- Neworder	0.48	0.86	5.54	
- Payment	0.38	0.76	2.73	
- Order Status	0.41	0.79	5.45	
- Delivery (interactive portion)	0.16	0.34	1.30	
- Delivery (deferred portion)	0.32	0.55	1.86	
- Stock-Level	1.37	2.18	5.12	
- Menu	0.17	0.35	1.32	
Response time delay added for emulated components				Menu 0.1 Resp 0.1
<b>Transaction Mix</b> , in percent of total transactions				
- New-Order				44.84%
- Payment				43.02 %
- Order-Status				4.04 %
- Delivery				4.05 %
- Stock-Level				4.05 %
<b>Keying/Think Times</b> (in seconds),	Min	Average	Max	
- New-Order	18.01	0.0	18.02	12.04
- Payment	3.01	0.0	3.02	12.04
- Order-Status	2.01	0.0	2.02	10.02
- Delivery	2.01	0.0	2.02	5.06
- Stock-Level	2.01	0.0	2.02	5.06
<b>Test Duration</b>				
- Ramp-up time				5 minutes
- Measurement interval				30 minutes
- Number of checkpoints				1
- Checkpoint interval				30 minutes
- Number of transactions (all types) completed in measurement interval				2,104,156

# Table of Contents

---

<b>ABSTRACT .....</b>	<b>1</b>
OVERVIEW .....	1
AUDITOR .....	1
<b>TABLE OF CONTENTS .....</b>	<b>1</b>
<b>INTRODUCTION .....</b>	<b>5</b>
DOCUMENT STRUCTURE .....	5
BENCHMARK OVERVIEW .....	5
SYSTEM OVERVIEW .....	6
<b>GENERAL ITEMS .....</b>	<b>7</b>
TEST SPONSOR .....	7
APPLICATION CODE AND DEFINITION STATEMENTS .....	7
PARAMETER SETTINGS .....	7
CONFIGURATION DIAGRAMS .....	8
<b>CLAUSE 1 -- LOGICAL DATABASE DESIGN RELATED ITEMS .....</b>	<b>10</b>
TABLE DEFINITIONS .....	11
PHYSICAL ORGANIZATION OF THE DATABASE .....	11
INSERT AND DELETE OPERATIONS .....	11
HORIZONTAL AND VERTICAL PARTITIONING .....	11
REPLICATION .....	11
TABLE ATTRIBUTES .....	11
<b>CLAUSE 2 -- TRANSACTION AND TERMINAL PROFILES RELATED ITEMS .....</b>	<b>12</b>
RANDOM NUMBER GENERATION .....	12
SCREEN LAYOUT .....	12
TERMINAL VERIFICATION .....	12
INTELLIGENT TERMINALS .....	12
TRANSACTION PROFILES .....	12
TRANSACTION MIX .....	13
DEFERRED DELIVERY MECHANISM .....	13
<b>CLAUSE 3 -- TRANSACTION AND SYSTEM PROPERTIES RELATED ITEMS .....</b>	<b>14</b>
ACID TESTS .....	14
<i>Atomicity</i> .....	14
<i>Consistency</i> .....	14
<i>Isolation</i> .....	14
<i>Durability</i> .....	15
<b>CLAUSE 4 -- SCALING AND DATABASE POPULATION RELATED ITEMS .....</b>	<b>17</b>
TABLE CARDINALITY .....	17
CONSTANT VALUES .....	17
DATA DISTRIBUTION .....	18
PARTITION MAPPING .....	20
60 DAY SPACE CALCULATION .....	21
<b>CLAUSE 5 -- PERFORMANCE METRICS AND RESPONSE TIME RELATED ITEMS .....</b>	<b>22</b>

MEASURED TPMC.....	22
RESPONSE TIMES .....	22
THINK TIMES & KEY TIMES.....	22
RESPONSE TIME DISTRIBUTION CURVES .....	23
NEW-ORDER RESPONSE TIME VS. THROUGHPUT GRAPH.....	26
NEW-ORDER THINK TIME DISTRIBUTION GRAPH.....	27
STEADY-STATE GRAPH .....	27
STEADY-STATE METHODOLOGY .....	28
WORK PERFORMED DURING STEADY STATE.....	28
REPRODUCIBILITY METHODOLOGY .....	29
MEASUREMENT INTERVAL.....	29
TRANSACTION MIX .....	29
OTHER METRICS .....	29
CHECKPOINTS.....	30
<b>CLAUSE 6 -- SUT, DRIVER, AND COMMUNICATION DEFINITION RELATED ITEMS .....</b>	<b>31</b>
RTE PARAMETERS .....	31
EMULATED COMPONENTS .....	31
BENCHMARKED AND TARGETED SYSTEM CONFIGURATION DIAGRAMS .....	31
NETWORK CONFIGURATION.....	31
NETWORK BANDWIDTH.....	31
OPERATOR INTERVENTION .....	32
<b>CLAUSE 7 -- PRICING RELATED ITEMS .....</b>	<b>33</b>
HARDWARE AND SOFTWARE LIST .....	33
AVAILABILITY DATE .....	33
MEASURED TPMC.....	33
COUNTRY SPECIFIC PRICING .....	33
USAGE PRICING .....	33
SYSTEM PRICING.....	34
<b>CLAUSE 9 -- AUDIT RELATED ITEMS .....</b>	<b>35</b>
AUDITOR.....	35
AVAILABILITY OF THE FULL DISCLOSURE REPORT .....	35
AUDITOR'S LETTER OF ATTESTATION .....	ERROR! BOOKMARK NOT DEFINED.
<b>APPENDIX A - APPLICATION SOURCE CODE.....</b>	<b>39</b>
TPCC.DLL ISAPI DLL SOURCE CODE .....	39
<i>isapi_dll/src/tpcc.def</i> .....	39
<i>isapi_dll/src/tpcc.h</i> .....	39
<i>isapi_dll/src/tpcc.rc</i> .....	41
<i>isapi_dll/src/tpcc.cpp</i> .....	42
<i>isapi_dll/src/resource.h</i> .....	63
<i>common/src/ReadRegistry.cpp</i> .....	63
<i>common/src/ReadRegistry.h</i> .....	64
<i>common/src/error.h</i> .....	65
<i>common/src/trans.h</i> .....	67
<i>common/src/txn_base.h</i> .....	68
<i>db_dblib_dll/src/tpcc_dblib.cpp</i> .....	69
<i>db_dblib_dll/src/tpcc_dblib.h</i> .....	78
<i>tm_com_dll/src/tpcc_com.cpp</i> .....	79
<i>tm_com_dll/src/tpcc_com.h</i> .....	81
<i>tpcc_com_all/src/methods.h</i> .....	82
<i>tpcc_com_all/src/resource.h</i> .....	85

<i>tpcc_com_all/src/tpcc_com_all.cpp</i> .....	85
<i>tpcc_com_all/src/tpcc_com_all.def</i> .....	90
<i>tpcc_com_all/src/tpcc_com_all.h</i> .....	90
<i>tpcc_com_all/src/tpcc_com_all.idl</i> .....	91
<i>tpcc_com_all/src/tpcc_com_all.rc</i> .....	92
<i>tpcc_com_all/src/tpcc_com_all.rgs</i> .....	93
<i>tpcc_com_all/src/tpcc_com_all_i.c</i> .....	93
<i>tpcc_com_all/src/tpcc_com_no.rgs</i> .....	95
<i>tpcc_com_all/src/tpcc_com_os.rgs</i> .....	95
<i>tpcc_com_all/src/tpcc_com_pay.rgs</i> .....	95
<i>tpcc_com_all/src/tpcc_com_ps.h</i> .....	96
<i>tpcc_com_all/src/tpcc_com_sl.rgs</i> .....	98
<i>tpcc_com_ps/src/dlldata.c</i> .....	98
<i>tpcc_com_ps/src/tpcc_com_ps.def</i> .....	99
<i>tpcc_com_ps/src/tpcc_com_ps.h</i> .....	99
<i>tpcc_com_ps/src/tpcc_com_ps.idl</i> .....	101
<i>tpcc_com_ps/src/tpcc_com_ps_i.c</i> .....	102
<i>tpcc_com_ps/src/tpcc_com_ps_p.c</i> .....	103
<i>common/txnlog/include/rtime.h</i> .....	124
<i>common/txnlog/include/spinlock.h</i> .....	124
<i>common/txnlog/include/txnlog.h</i> .....	125
<b>APPENDIX B - DATABASE DESIGN</b> .....	<b>129</b>
BUILD SCRIPTS .....	129
<i>setup.cmd</i> .....	129
<i>createdb.sql</i> .....	130
<i>tables.sql</i> .....	131
<i>idxcuscl.sql</i> .....	132
<i>idxcusnc.sql</i> .....	132
<i>idxdiscl.sql</i> .....	133
<i>idxitmcl.sql</i> .....	133
<i>idxnodcl.sql</i> .....	133
<i>idxodlcl.sql</i> .....	134
<i>idxordcl.sql</i> .....	134
<i>idxstkcl.sql</i> .....	134
<i>idxwarcl.sql</i> .....	134
<i>dbopt1.sql</i> .....	135
<i>dbopt2.sql</i> .....	135
<i>dbopt3.sql</i> .....	136
<i>backup.sql</i> .....	136
<i>restore.sql</i> .....	136
STORED PROCEDURES .....	137
<i>neword.sql</i> .....	137
<i>payment.sql</i> .....	139
<i>ordstat.sql</i> .....	141
<i>delivery.sql</i> .....	142
<i>stocklev.sql</i> .....	143
LOADER SOURCE CODE .....	143
<i>tpcc.h</i> .....	143
<i>tpccldr.c</i> .....	145
<i>getargs.c</i> .....	165
<i>random.c</i> .....	166
<i>strings.c</i> .....	168
<i>time.c</i> .....	171

<b>APPENDIX C - TUNABLE PARAMETERS .....</b>	<b>172</b>
SERVER CONFIGURATION PARAMETERS .....	172
<i>Microsoft Windows 2000 Advanced Server Parameters .....</i>	172
<i>Microsoft Windows 2000 Advanced Server Configuration .....</i>	172
<i>Microsoft SQL Server Version 7.0 Startup Parameters .....</i>	172
<i>Microsoft SQL Server Stack Size .....</i>	173
<i>Mylex Device Drivers and Firmware .....</i>	173
<i>Mylex Registry Key .....</i>	173
<i>Qlogic Device Driver .....</i>	<b>Error! Bookmark not defined.</b>
<i>Giganet Registry Key .....</i>	<b>Error! Bookmark not defined.</b>
<i>Microsoft SQL Server 7.0 Configuration Parameters .....</i>	173
<i>Windows 2000 Advanced Server System Information Report For PE6400 .....</i>	174
CLIENT CONFIGURATION PARAMETERS .....	221
<i>COM+ Settings .....</i>	221
<i>TPCC Application Registry Parameters .....</i>	221
<i>Microsoft Internet Information Server Registry Parameters .....</i>	221
<i>World Wide Web Service Registry Parameters .....</i>	222
<i>Microsoft Windows 2000 Server System Information Report for PE1300 .....</i>	224
RTE INPUT PARAMETERS .....	270
<i>BenchCraft Configuration File .....</i>	270
<b>APPENDIX D – DISK STORAGE .....</b>	<b>281</b>
60 DAY SPACE .....	281
<b>APPENDIX E - PRICE QUOTATIONS .....</b>	<b>283</b>

# Introduction

---

## **Document Structure**

The TPC Benchmark C Standard Specification Revision 3.5, written and approved by the Transaction Processing Performance Council (TPC), determines the contents of this report. The format of this report is based on this specification. Most sections of this report begin with the specification requirements printed in italic type, immediately followed by the detail in plain type of how Dell complied with the specification. Where extensive listings are required (such as listing of code), a note is included which references an appendix containing the listing.

## **Benchmark Overview**

TPC Benchmark™ C (TPC-C) is an OLTP workload. It is a mixture of read-only and update intensive transactions that simulate the activities found in complex OLTP application environments. It does so by exercising a breadth of system components associated with such environments, which are characterized by:

- The simultaneous execution of multiple transaction types that span a breadth of complexity
- On-line and deferred transaction execution modes
- Multiple on-line terminal sessions
- Moderate system and application execution time
- Significant disk input/output
- Transaction integrity (ACID properties)
- Non-uniform distribution of data access through primary and secondary keys
- Databases consisting of many tables with a wide variety of sizes, attributes, and relationships
- Contention on data access and update

The performance metric reported by TPC-C is a "business throughput" measuring the number of orders processed per minute. Multiple transactions are used to simulate the business activity of processing an order, and each transaction is subject to a response time constraint.

The performance metric for this benchmark is expressed in transactions-per-minute-C (tpmC). To be compliant with the TPC-C standard, all references to tpmC results must include the tpmC rate, the associated price-per-tpmC, and the availability date of the priced configuration.

Although these specifications express implementation in terms of a relational data model with conventional locking scheme, the database may be implemented using any commercially available database management system (DBMS), database server, file system, or other data repository that provides a functionally equivalent implementation. The terms "table", "row", and "column" are used in this document only as examples of logical data structures.

TPC-C uses terminology and metrics that are similar to other benchmarks, originated by the TPC or others. Such similarity in terminology does not in any way imply that TPC-C results are comparable to other benchmarks. The only benchmark results comparable to TPC-C are other TPC-C results conformant with the same revision.

Despite the fact that this benchmark offers a rich environment that emulates many OLTP applications, this benchmark does not reflect the entire range of OLTP requirements. In addition, the extent to which a customer can achieve the results reported by a vendor is highly dependent on how closely TPC-C approximates the customer application. The relative performance of

systems derived from this benchmark does not necessarily hold for other workloads or environments. Extrapolations to any other environment are not recommended.

Benchmark results are highly dependent upon workload, specific application requirements, and systems design and implementation. Relative system performance will vary as a result of these and other factors. Therefore, TPC-C should not be used as a substitute for a specific customer application benchmarking when critical capacity planning and/or product evaluation decisions are contemplated.

## **System Overview**

The hardware configuration used in this TPC-C test is a Dell PowerEdge 6450 server driven by four Dell PowerEdge 1300 clients. The clients and server are networked together via a 10/100 Base T switch. Nine remote terminal emulator (RTE) systems (PowerEdge 2200's) emulate 24,320 users executing the standard TPC-C workload. The RTE's are connected to the four clients through 10/100 BaseT switches. Each switch connects to one client machine at 100 BaseT and to the RTE machines at 10Mbit/sec, half duplex. Microsoft Windows 2000 Advanced Server was the operating system used on the server. Microsoft Windows 2000 Server was used on the clients. Microsoft SQL Server 2000 Enterprise Edition was the database on the server machine.

The PowerEdge 6450 motherboard uses the ServerWorks Champion High End 2.5 chipset and can hold up to four Pentium® III Xeon™ processors (700 MHz with 2 MB L2 cache on each). The system has 7 PCI I/O slots (2 x 64bit/66MHz; 4 x 64-bit/33MHz; 1 x 32-bit/33MHz ). The measured configuration used 8 Gbytes of RAM, which was achieved by using sixteen 512 Mbyte DIMMs.

The PowerEdge 6450 has an integrated Adaptec AIC-7899 U160 SCSI controller to which was attached one 9 GB disk drive containing the operating system. In addition, four Mylex ExtremeRAID 2000 4-channel RAID controllers were installed in four PCI slots and connected to 11 PowerVault 210S disk pods, which can hold 12 disks each. 9 of the pods were filled with 108 18 GB disks, all containing the database data. Additionally, 2 of the diskpods held 5 disk drives each. The 10 disk drives were mirrored using RAID 10 and were configured for transaction log data. There were 2 empty slots. The final PCI slot was used for an Intel Pro 100 Network Interface Card.

Each client had a single Pentium® III processor (three at 600 MHz and one at 550 MHz), each with 512 Kbytes of L2 cache. Each client had 512 Mbytes of RAM, one 9 GB hard disk, one Intel Ether Express Pro100+ PCI Ethernet adapter and one Intel Pro 100 Network Interface Card. On each client the Intel Ethernet adapter was connected to the RTE machines through a 10/100 BaseT switch and the Intel Pro NIC was connected to the Database Server through a 10/100 Base T switch. The four clients were driven through eight network segments each for a total of 32 network segments. 760 emulated users were run on each network segment for a total of 24,320 emulated users. The network segments between the switches and RTEs were fixed at 10 Mbit/sec, half duplex.

## General Items

---

### **Test Sponsor**

*A statement identifying the sponsor of the Benchmark and any other companies who have participated.*

Dell was the test sponsor of this TPC Benchmark™ C.

### **Application Code and Definition Statements**

*The application program must be disclosed. This includes, but is not limited to, the code implementing the five transactions and the terminal input/output functions.*

The application consists of the Microsoft Benchcraft Remote Terminal Emulator (RTE) program emulating a set of users entering TPC-C transactions through web browsers, and communicating with Client machines running the Microsoft Internet Information Server (IIS) web server. The Client machines use the COM+ transaction monitor to communicate with the database server machine.

On each Client machine IIS loads a custom Microsoft Internet Information Server Application Programming Interface dynamic link library (ISAPI DLL) application program that communicates with the emulated web browsers through the HTTP protocol and with the database server through the COM+ transaction monitor and the Microsoft DBLIB interface. The application supplies fill-in screens to the user for each transaction, then parses the data in each request, and makes a call on SQL Server through the COM+ layer, which manages a set of DBLIB connections to the database server. The resulting data is passed back to the application where it is formatted into HTML and sent back to the user's browser. The Delivery transaction is handled directly from the application to the database without the use of COM+.

The web Client code is listed in Appendix A.

### **Parameter Settings**

*Settings must be provided for all customer-tunable parameters and options which have been changed from the default found in actual products; including but not limited to:*

- *Database options*
- *Recover/commit options*
- *Consistency/locking options*
- *System parameter, application parameters, and configuration parameters.*

*This requirement can be satisfied by providing a full listing of all parameters and options.*

Appendix C contains all the database, Windows 2000 Advanced Server, Windows 2000 Server, and Internet Information Service parameters used in this benchmark.

Appendix D contains the 60 day space calculations.

## **Configuration Diagrams**

*Diagrams of both the measured and priced system must be provided, accompanied by a description of the differences.*

Figures 1 and 2 respectively show the measured and priced full client/server configurations. The system under test (SUT) in the measured system was identical to what was priced.

**Figure 1: Measured Configuration**

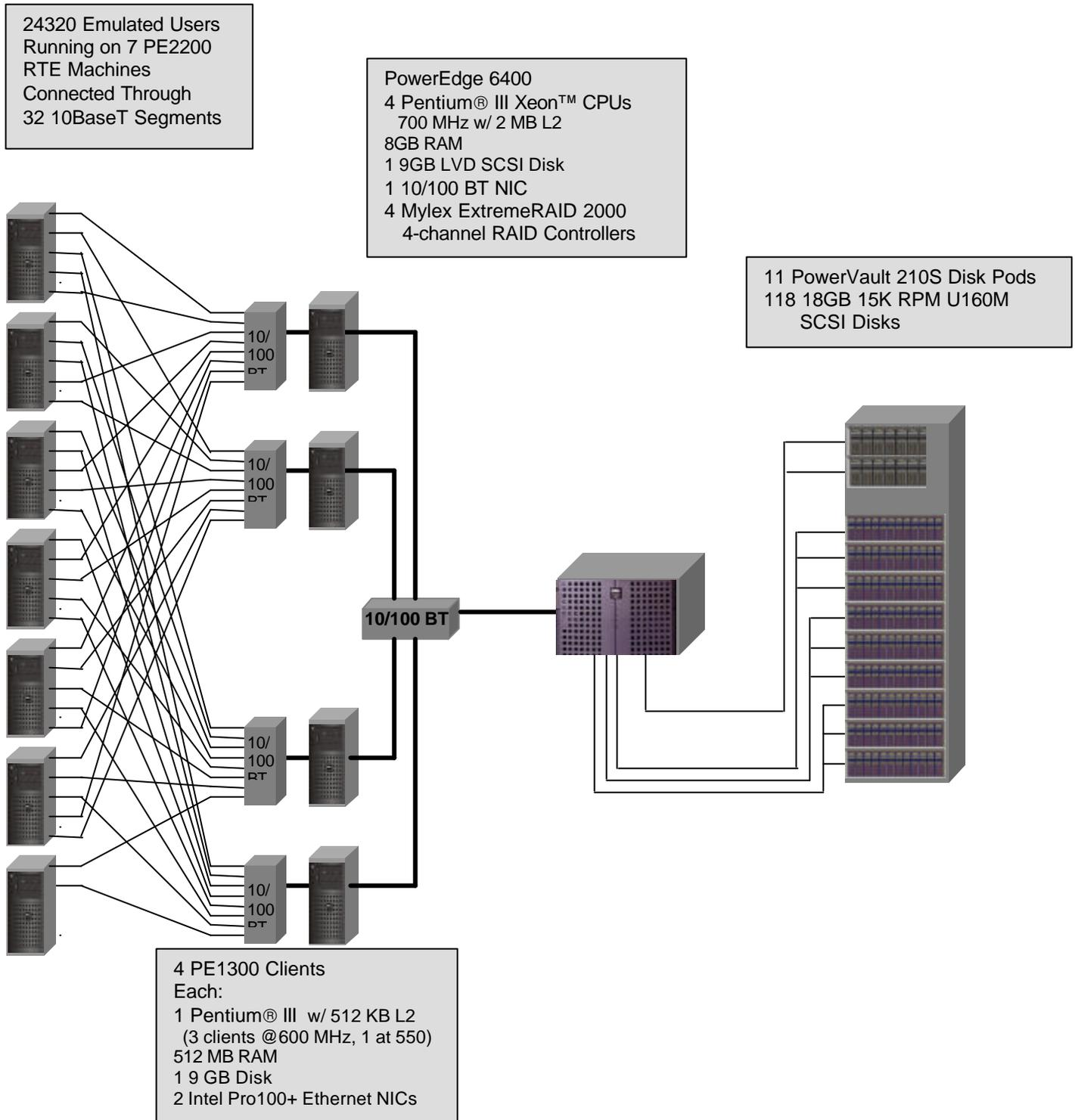

**Figure 2: Priced Configuration**

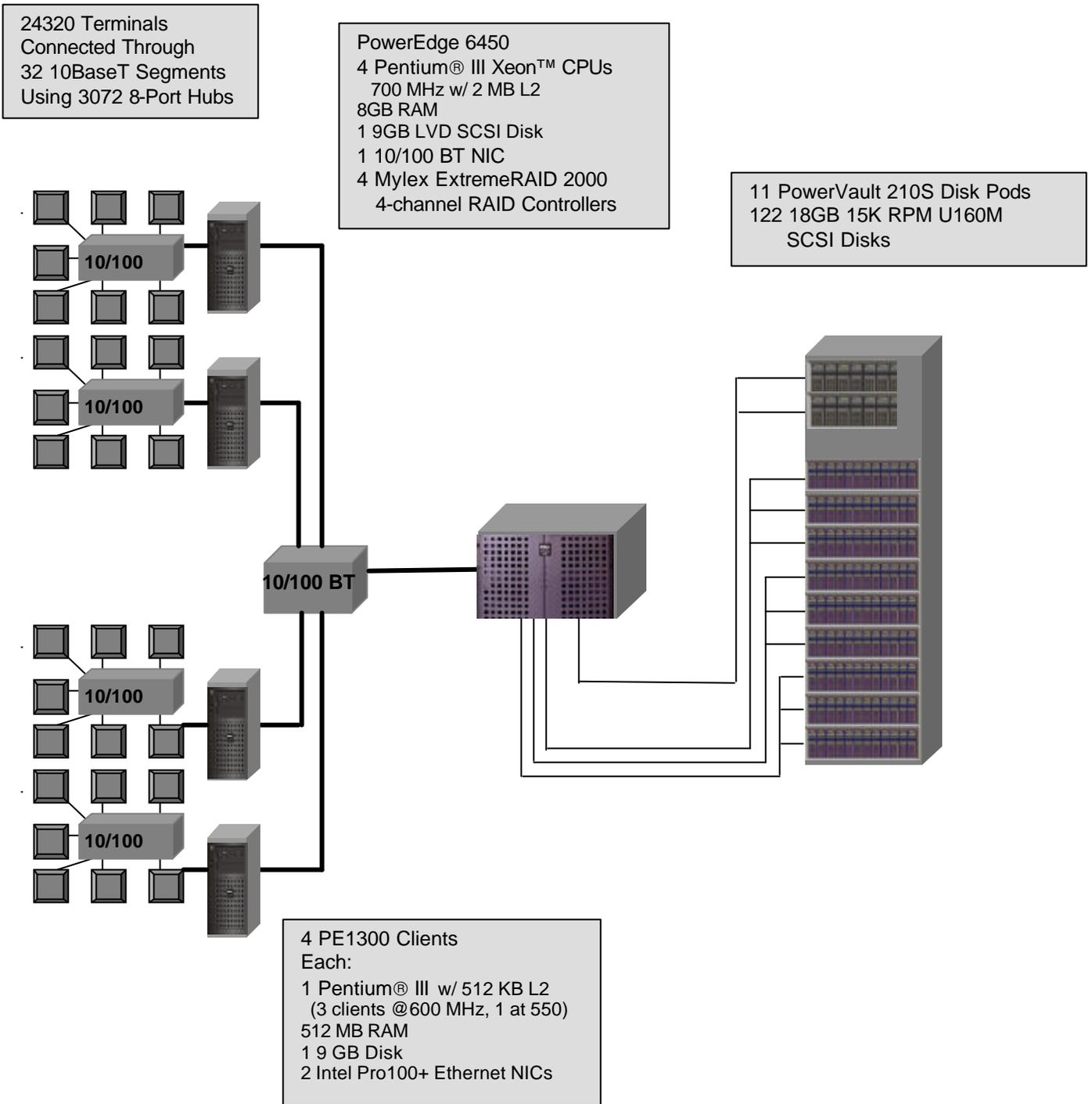

## Clause 1 -- Logical Database Design Related Items

---

### **Table Definitions**

*Listings must be provided for all table definition statements and all other statements used to set-up the database. (8.1.2.1)*

Appendix B contains the code used to define and load the database tables.

### **Physical Organization of the Database**

*The physical organization of tables and indices, within the database, must be disclosed. (8.1.2.2)*

The measured configuration used 118 disk drives. The organization is shown in Table 5: Data Distribution.

### **Insert and Delete Operations**

*It must be ascertained that insert and/or delete operations to any of the tables can occur concurrently with the TPC-C transaction mix. Furthermore, any restriction in the SUT database implementation that precludes inserts beyond the limits defined in Clause 1.4.11 must be disclosed. This includes the maximum number of rows that can be inserted and the maximum key value for these new rows. (8.1.2.3)*

Insert and delete functionality was fully operational during the benchmark.

### **Horizontal and Vertical Partitioning**

*While there are a few restrictions placed upon horizontal or vertical partitioning of tables and rows in the TPC-C benchmark (see Clause 1.6), any such partitioning must be disclosed. (8.1.2.4)*

Partitioning was not used in this benchmark.

### **Replication**

*Replication of tables, if used, must be disclosed (see Clause 1.4.6). (8.1.2.5)*

Replication was not used in this benchmark.

### **Table Attributes**

*Additional and/or duplicated attributes in any table must be disclosed along with a statement on the impact on performance (see Clause 1.4.7). (8.1.2.6)*

No additional attributes were used in this benchmark.

## Clause 2 -- Transaction and Terminal Profiles Related Items

---

### **Random Number Generation**

*The method of verification for the random number generation must be described. (8.1.3.1)*

The random number generation was done internal to the Microsoft BenchCraft RTE program, which was audited independently.

### **Screen Layout**

*The actual layouts of the terminal input/output screens must be disclosed. (8.1.3.2)*

The screen layouts are based on those in Clauses 2.4.3, 2.5.3, 2.6.3, 2.7.3, and 2.8.3 of the TPC-C Standard Specification. There are some very minor differences based on the fact that this is a web client implementation.

### **Terminal Verification**

*The method used to verify that the emulated terminals provide all the features described in Clause 2.2.2.4 must be explained. Although not specifically priced, the type and model of the terminals used for the demonstration in 8.1.3.3 must be disclosed and commercially available (including supporting software and maintenance). (8.1.3.3)*

The terminal features were verified by allowing the auditor to manually execute each of the five transaction types, using Microsoft Internet Explorer version 3.0.

### **Intelligent Terminals**

*Any usage of presentation managers or intelligent terminals must be explained. (8.1.3.4)*

**Comment 1:** *The intent of this clause is to describe any special manipulations performed by a local terminal or workstation to off-load work from the SUT. This includes, but is not limited to: screen presentations, message bundling, and local storage of TPC-C rows.*

**Comment 2:** *This disclosure also requires that all data manipulation functions performed by the local terminal to provide navigational aids for transaction(s) must also be described. Within this disclosure, the purpose of such additional function(s) must be explained.*

Application code involved in the manipulation of data was run on the client. Screen manipulation commands in the form of HTML were downloaded to the web browser, which handled input and output presentation graphics. A listing of this code is included in Appendix A. Microsoft Internet Information Service assisted in the processing and presentation of this data.

### **Transaction Profiles**

*The percentage of home and remote order-lines in the New-Order transactions must be disclosed. (8.1.3.5)*

*The percentage of New-Order transactions that were rolled back as a result of an unused item number must be disclosed. (8.1.3.6)*

*The number of items per orders entered by New-Order transactions must be disclosed. (8.1.3.7)*

*The percentage of home and remote Payment transactions must be disclosed. (8.1.3.8)*

*The percentage of Payment and Order-Status transactions that used non-primary key (C\_LAST) access to the database must be disclosed. (8.1.3.9)*

*The percentage of Delivery transactions that were skipped as a result of an insufficient number of rows in the NEW-ORDER table must be disclosed. (8.1.3.10)*

**Table 1: Transaction Statistics**

<b>Transaction</b>	<b>Function</b>	<b>Value</b>
New Order	Home Warehouse Items	99.00%
	Remote Warehouse Items	1.00%
	Rolled Back Transactions	0.99%
	Average Lines Per Order	10.00
Payment	Home Warehouse	84.94%
	Remote Warehouse	15.06%
	Non-Primary Key Access	60.03%
Order Status	Non-Primary Key Access	60.20%
Delivery	Skipped Transactions	0

**Transaction Mix**

*The mix (i.e., percentages) of transaction types seen by the SUT must be disclosed. (8.1.3.11)*

**Table 2: Transaction Mix**

<b>Transaction</b>	<b>Percentage</b>
New Order	44.84%
Payment	43.02%
Order Status	4.04%
Delivery	4.05%
Stock Level	4.05%

**Deferred Delivery Mechanism**

*The queuing mechanism used to defer the execution of the Delivery transaction must be disclosed. (8.1.3.12)*

The application creates a semaphore-base thread pool consisting of a user-specified number of threads, which open DBLIB connections on the database. When a Delivery transaction is posted one of these threads makes the database call while the transaction's original thread returns control to the user. Upon completion the Delivery thread writes an entry in the Delivery log and returns to the thread pool.

The source code is listed in Appendix A.

## Clause 3 -- Transaction and System Properties Related Items

---

### **ACID Tests**

*The results of the ACID tests must be disclosed along with a description of how the ACID requirements were met. This includes disclosing which case was followed for the execution of Isolation Test 7. (8.1.4.1)*

All ACID property tests were successful. The executions are described below.

### Atomicity

*The system under test must guarantee that the database transactions are atomic; the system will either perform all individual operations on the data or will assure that no partially completed operations leave any effects on the data.*

### **Completed Transactions**

A row was selected in a script from the warehouse, district and customer tables, and the balances noted. A payment transaction was started with the same warehouse, district and customer identifiers and a known amount. The payment transaction was committed and the rows were verified to contain correctly updated balances.

### **Aborted Transactions**

A row was selected in a script from the warehouse, district and customer tables, and the balances noted. A payment transaction was started with the same warehouse, district and customer identifiers and a known amount. The payment transaction was rolled back and the rows were verified to contain the original balances.

### Consistency

*Consistency is the property of the application that requires any execution of a database transaction to take the database from one consistent state to another, assuming that the database is initially in a consistent state.*

Consistency conditions one through four were tested using a shell script to issue queries to the database. The results of the queries verified that the database was consistent for all four tests. A run was executed under full load lasting over ten (10) minutes and included a checkpoint. The shell script was executed again. The result of the same queries verified that the database remained consistent after the run.

### Isolation

*Sufficient conditions must be enabled at either the system or application level to ensure the required isolation defined above (clause 3.4.1) is obtained.*

Isolation tests one through seven were executed using shell scripts to issue queries to the database. Each script included timestamps to demonstrate the concurrency of operations. The results of the queries were captured to files. The captured files were verified by the auditor to demonstrate the required isolation had been met.

In addition, the phantom tests and the stock level tests were executed and verified.

For Isolation test seven, case A was followed.

## Durability

*The tested system must guarantee durability: the ability to preserve the effects of committed transactions and insure database consistency after recovery from any one of the failures listed in Clause 3.5.3.*

### Durable Media Failure

For convenience, durability from media failure was demonstrated on a 10 Warehouse database having similar characteristics to the fully scaled database. The standard driving mechanism was used to generate the transaction load of 100 users for the Loss of Data. The fully scaled database under full load would also have passed the following test.

### Loss of Data

Loss of data was demonstrated on a 10 Warehouse database for convenience. The standard driving mechanism was used to generate the transaction load of 100 users for the test. To demonstrate recovery from a permanent failure of durable media containing TPC-C tables, the following steps were executed:

1. A 10 Warehouse database was built having similar characteristics to the large database.
2. The database was backed up using SQL Server backup facilities.
3. A sum of D\_NEXT\_O\_ID was taken.
4. 100 users were logged in to the database and ran transactions.
5. One disk drive in the data array was removed causing SQL Server errors.
6. The RTE was allowed to continue running. Completed transactions enroute from the clients were recorded. Error messages began appearing on the RTE screen.
7. The RTE was stopped.
8. SQL Server was stopped and restarted and a dump of the transaction log was taken.
9. SQL Server was stopped, Windows 2000 was shutdown and the machine powered off.
10. The failed disk was replaced.
11. The machine was powered up, Windows 2000 and SQL Server were started.
12. The TPC-C database was dropped and restored from backup.
13. The transaction log was restored and transactions rolled forward.
14. A new count of D\_NEXT\_O\_ID was taken.
15. This number was compared with the number of new orders reported by the RTE.

### Instantaneous Interruption and Loss of Memory/Loss of Log

Instantaneous Interruption and Loss of Memory were demonstrated on the full database with 2560 warehouses in a single test. The standard driving mechanism was used to generate the transaction load of 25,600 users for the test. To demonstrate recovery an instantaneous system interruption caused by powering off the Server, the following steps were executed:

1. The full database was used.
2. A sum of D\_NEXT\_O\_ID was taken.
3. 25,600 users were logged in to the database and ran transactions.
4. The system was run in steady state for 5 minutes
5. One disk drive in the transaction log array was removed with no effect on Windows 2000 or SQL Server.
6. The system ran for an additional 5 minutes.

6. The Server was powered off by normal means, causing instantaneous interruption.
7. The RTE was allowed to continue running. Completed transactions enroute from the clients were recorded. Error messages began appearing on the RTE screen.
8. The RTE was stopped.
9. The server was powered on again and rebooted.
10. SQL Server was restarted and automatically recovered.
11. A new count of D\_NEXT\_O\_ID was taken.
12. This number was compared with the number of new orders reported by the RTE

## Clause 4 -- Scaling and Database Population Related Items

---

### **Table Cardinality**

The cardinality (e.g., the number of rows) of each table, as it existed at the start of the benchmark run (see Clause 4.2), must be disclosed. If the database was over-scaled and inactive rows of the WAREHOUSE table were deleted (see Clause 4.2.2), the cardinality of the WAREHOUSE table as initially configured and the number of rows deleted must be disclosed. (8.1.5.1)

The database was originally built with 2450 warehouses. The performance run used 2432 warehouses and this is verified by runcheck

**Table 3: Table Cardinality**

<b>Table</b>	<b>Cardinality as Benchmarked</b>
Warehouse	2,450
District	24,500
Customer	73,500,000
History	73,500,000
NewOrder	22,050,000
Orders	73,500,000
OrderLine	734,999,144
Item	100,000
Stock	245,000,000
Deleted Warehouses	0

### **Constant Values**

The following values were used as constant value inputs to the NURand function for this benchmark.

**Table 4: Constant Values**

<b>Function</b>	<b>Constant C Value</b>
C_LAST (Build)	123
C_LAST (Run)	208

## Data Distribution

The distribution of tables and logs across all media must be explicitly depicted for the tested and priced systems. (8.1.5.2)

The Database was built using a total of 118 disks: 108 18GB for data, 10 18GB for log, and 1 9GB for OS and application software. The data drives were configured as hardware RAID 0. Logs were configured as hardware RAID 10. Mylex ExtremeRAID 2000 RAID Controllers 2, 3, and 4 were configured with 36 disk drives per logical drive. Disk 1 (controller 1) contained 10 18GB drives. Each Windows 2000 data drive contained 3 partitions: partition 1 for customer/stock, partition 2 for miscellaneous, and partition 3 for backup. Partitions 1 and 2 were RAW file systems and partition 3 was formatted NTFS. The details are shown in Table 5.

**Table 5: Data Distribution**

W2K Disk Administration		Adaptec 7899 Configuration					
Disk 0 8673MB		On-Board Controller # 1					
Partition		On-Board		Channels			
1		Internal	SCSI ID	0			
C: OS NTFS 8673 MB			0	A0-1			
			1				
			2				
			3				

W2K Disk Administration		MYLEX EX2000P Configuration					
Disk 1 85790MB		Controller # 1					
Partition		Slot# 1		Channels			
1	2		SCSI ID	A	B	C	D
S: LOG Unknown 55296MB	Freespace 30494MB		0	A1-1	A1-2		
			1	A2-1	A2-2		
			2	A3-1	A3-2		
			3	A4-1	A4-2		
			4	A5-1	A5-2		
			5				
			8				
			9				
			10				
			11				
			12				
			13				

W2K Disk Administration			MYLEX EX2000P Configuration					
Disk 2 617758MB			Controller # 2					
Partition			Slot# 2		Channels			
1	2	3		SCSI ID	A	B	C	D
E: CS1 Unknown 47616MB	F: MS1 Unknown 26624MB	X: Backup1 NTFS 543518MB		0	A1-1	A2-1		A3-1
				1	A1-2	A2-2		A3-2
				2	A1-3	A2-3		A3-3
				3	A1-4	A2-4		A3-4
				4	A1-5	A2-5		A3-5
				5	A1-6	A2-6		A3-6
				8	A1-7	A2-7		A3-7
				9	A1-8	A2-8		A3-8
				10	A1-9	A2-9		A3-9
				11	A1-10	A2-10		A3-10
				12	A1-11	A2-11		A3-11
				13	A1-12	A2-12		A3-12

W2K Disk Administration			MYLEX EX2000P Configuration					
Disk 3 617758MB			Controller # 3					
Partition			Slot# 3		Channels			
1	2	3		SCSI ID	A	B	C	D
G: CS2 Unknown 47616MB	H: MS2 Unknown 26624MB	Y: Backup2 NTFS 543518MB		0	A1-1	A2-1		A3-1
				1	A1-2	A2-2		A3-2
				2	A1-3	A2-3		A3-3
				3	A1-4	A2-4		A3-4
				4	A1-5	A2-5		A3-5
				5	A1-6	A2-6		A3-6
				8	A1-7	A2-7		A3-7
				9	A1-8	A2-8		A3-8
				10	A1-9	A2-9		A3-9
				11	A1-10	A2-10		A3-10
				12	A1-11	A2-11		A3-11
				13	A1-12	A2-12		A3-12

W2K Disk Administration			MYLEX EX2000P Configuration					
Disk 4 617758MB			Controller # 4					
Partition			Slot# 4		Channels			
1	2	3		SCSI ID	A	B	C	D
I:	J:	U:		0	A1-1	A2-1		A3-1
CS2	MS2	Backup3		1	A1-2	A2-2		A3-2
Unknown	Unknown	NTFS		2	A1-3	A2-3		A3-3
47616MB	26624MB	543518MB		3	A1-4	A2-4		A3-4
				4	A1-5	A2-5		A3-5
				5	A1-6	A2-6		A3-6
				8	A1-7	A2-7		A3-7
				9	A1-8	A2-8		A3-8
				10	A1-9	A2-9		A3-9
				11	A1-10	A2-10		A3-10
				12	A1-11	A2-11		A3-11
				13	A1-12	A2-12		A3-12

**Comment:** Detailed diagrams for layout of database files on disks can widely vary, and it is difficult to provide exact guideline suitable for all implementations. The intent is to provide sufficient detail to allow independent reconstruction of the test database. The two figures below are examples of database layout descriptions and are not intended to depict or imply any optimal layout for the TPC-C database.

8.1.5.3 A statement must be provided that describes:

1. The data model implemented by the DBMS used (e.g., relational, network, hierarchical)
2. The database interface (e.g., embedded, call level) and access language (e.g., SQL, DL/1, COBOL read/write) used to implement the TPC-C transactions. If more than one interface/access language is used to implement TPC-C, each interface/access language must be described and a list of which interface/access language is used with which transaction type must be disclosed.

Microsoft SQL Server 2000 Enterprise Edition is a relational DBMS.

The interface used was Microsoft SQL Server stored procedures accessed with Remote Procedure Calls embedded in C code using the Microsoft DBLIB interface.

### Partition Mapping

The mapping of database partitions/replications must be explicitly described.

**Comment:** The intent is to provide sufficient detail about partitioning and replication to allow independent reconstruction of the test database. (8.1.5.4)

An description of a database partitioning scheme is presented below as an example. The nomenclature of this example was outlined using the CUSTOMER table (in Clause 8.1.2.1), and has been extended to use the ORDER and ORDER\_LINE tables as well.

The database was not replicated.

## **60 day Space Calculation**

*Details of the 60 day space computations along with proof that the database is configured to sustain 8 hours of growth for the dynamic tables (Order, Order-Line, and History) must be disclosed (see Clause 4.2.3). (8.1.5.5)*

To calculate the space required to sustain the database log for 8 hours of growth at steady state, the following steps were followed:

1. The current log space usage was determined by running *dbcc sqlperf(logspace)*
2. Transactions were run against the database with a full load of users.
3. The final log space usage was determined by running *dbcc sqlperf(logspace)*
4. The space used was calculated as the difference between the first and second query.
5. The number of NEW-ORDERS was verified from an RTE report covering the entire run.
6. The space used was divided by the number of NEW-ORDERS giving a spaceused per NEW-ORDER transaction.
7. The space used per transaction was multiplied by the measured tpmC rate times 480 minutes.

The results of the above steps yielded a requirement of 143.57 GB (including mirror) to sustain the log for 8 hours. Space available on the transaction log volume was 167.56 GB (including mirror), indicating that enough storage was configured to sustain 8 hours of growth.

The same methodology was used to compute growth requirements for dynamic tables Order, Order-Line and History.

The details of the 180-day space requirement is shown in Appendix D.

## Clause 5 -- Performance Metrics and Response Time Related Items

---

### Measured TpmC

Measured tpmC must be reported. (8.1.6.1)

Measured TpmC	30,231.37
Price per TpmC	\$6.98

### Response Times

Ninetieth percentile, maximum and average response times must be reported for all transaction types as well as for the Menu response time. (8.1.6.2)

**Table 6: Transaction Response Times**

Transaction	Average	90%	Maximum
New Order	0.48	0.86	5.54
Payment	0.38	0.76	2.73
Order Status	0.41	0.79	5.45
Interactive Delivery	0.16	0.34	1.30
Deferred Delivery	0.32	0.55	1.86
Stock Level	1.37	2.18	5.12
Menu	0.17	0.35	1.32

### Think Times & Key Times

The minimum, the average, and the maximum keying and think times must be reported for each transaction type. (8.1.6.3)

**Table 7: Transaction Key Times**

Transaction	Minimum	Average	Maximum
New Order	18.01	18.02	18.05
Payment	3.01	3.02	3.05
Order Status	2.01	2.02	2.05
Delivery	2.01	2.02	2.04
Stock Level	2.01	2.02	2.04

**Table 8: Transaction Think Times**

Transaction	Minimum	Average	Maximum
New Order	0.00	12.04	120.41
Payment	0.00	12.04	120.41
Order Status	0.00	10.02	100.41
Delivery	0.00	5.06	50.40
Stock Level	0.00	5.06	50.40

## Response Time Distribution Curves

Response Time frequency distribution curves (see Clause 5.6.1) must be reported for each transaction type. (8.1.6.4)

Figure 3: New Order Response Time Distribution

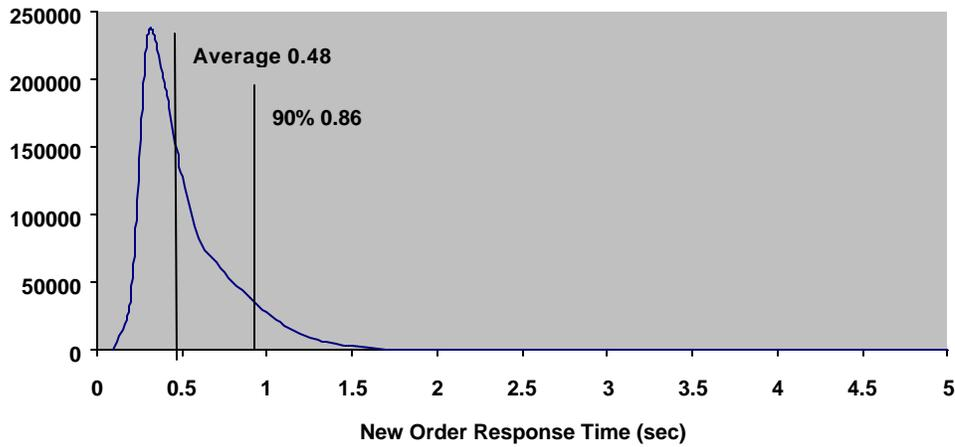

Figure 4: Payment Response Time Distribution

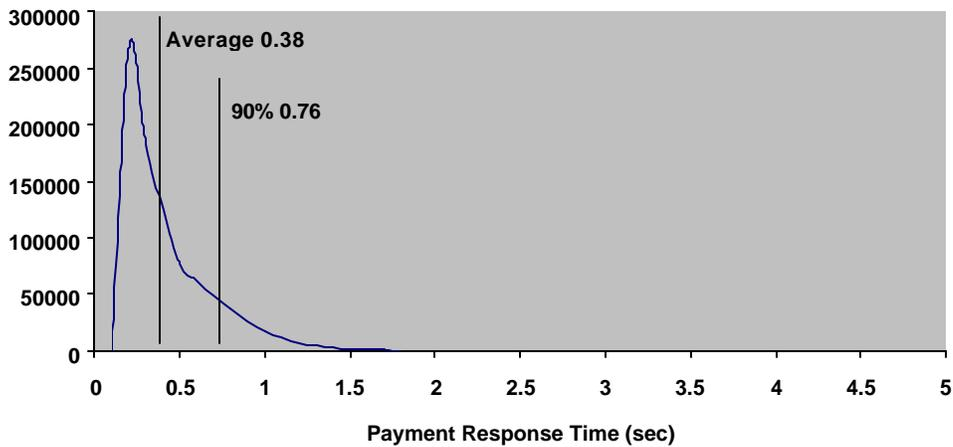

Figure 5: Order Status Response Time Distribution

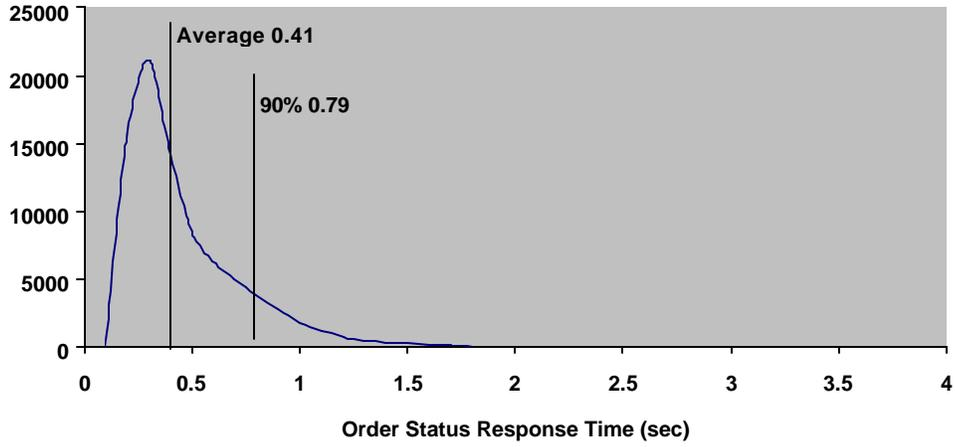

Figure 6: Delivery Response Time Distribution

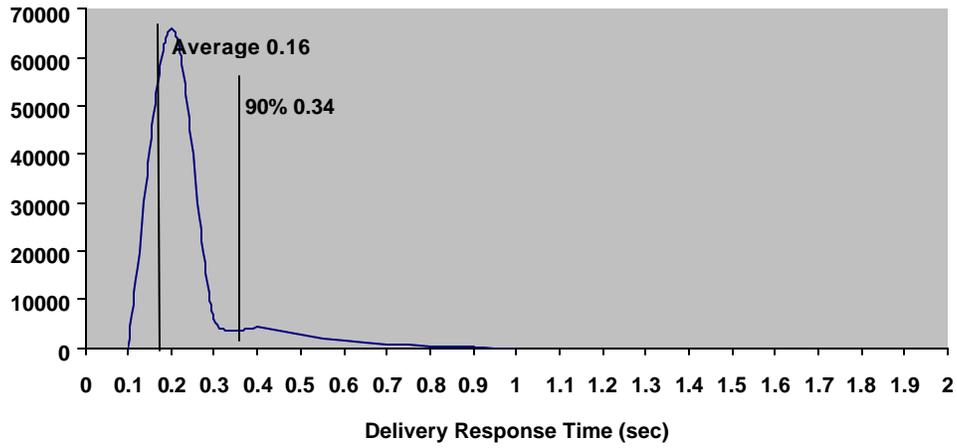
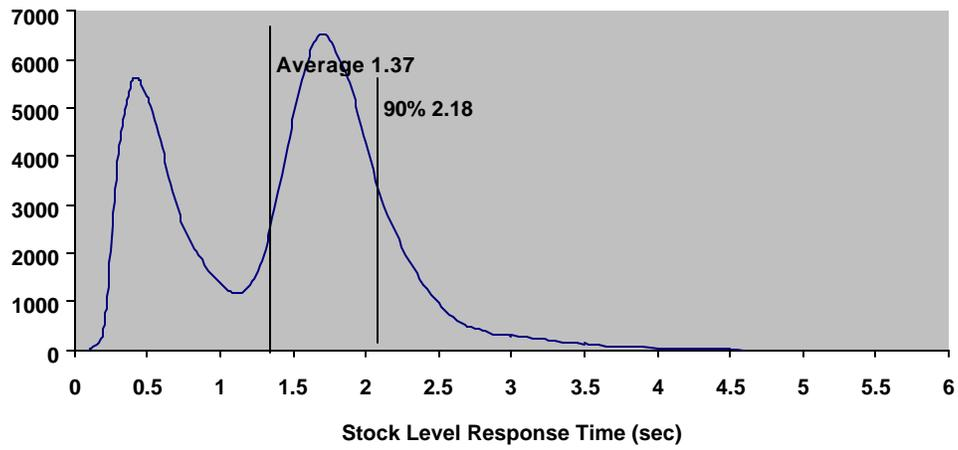

Figure 7: Stock Level Response Time Distribution



### ***New-Order Response Time vs. Throughput Graph***

*The performance curve for response times versus throughput (see Clause 5.6.2) must be reported for the New-Order transaction. (8.1.6.5)*

**Figure 8: New Order Response Time vs. Throughput**

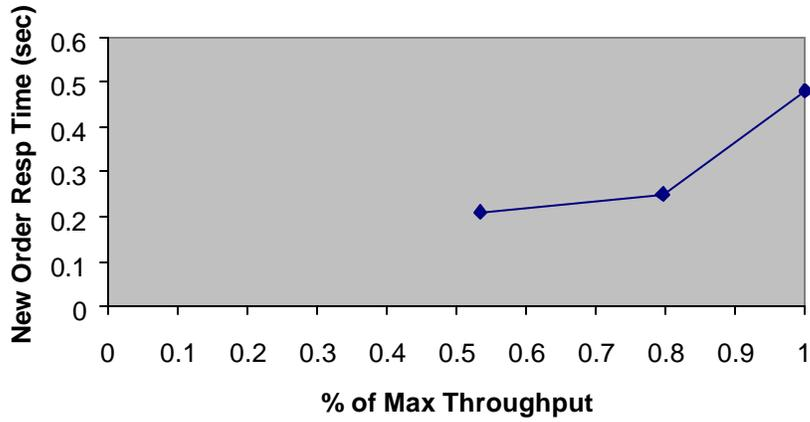

### New-Order Think Time Distribution Graph

Think Time frequency distribution curves (see Clause 5.6.3) must be reported for the New-Order transaction (8.1.6.6)

Figure 9: New Order Think Time Distribution

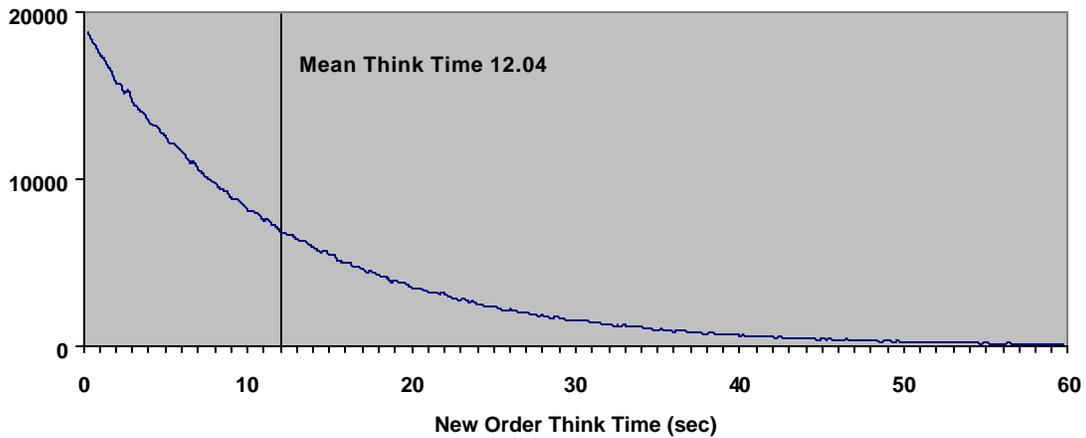

### Steady-State Graph

A graph of throughput versus elapsed time (see Clause 5.6.5) must be reported for the New-Order transaction. (8.1.6.8)

Figure 10: New Order Throughput vs. Time

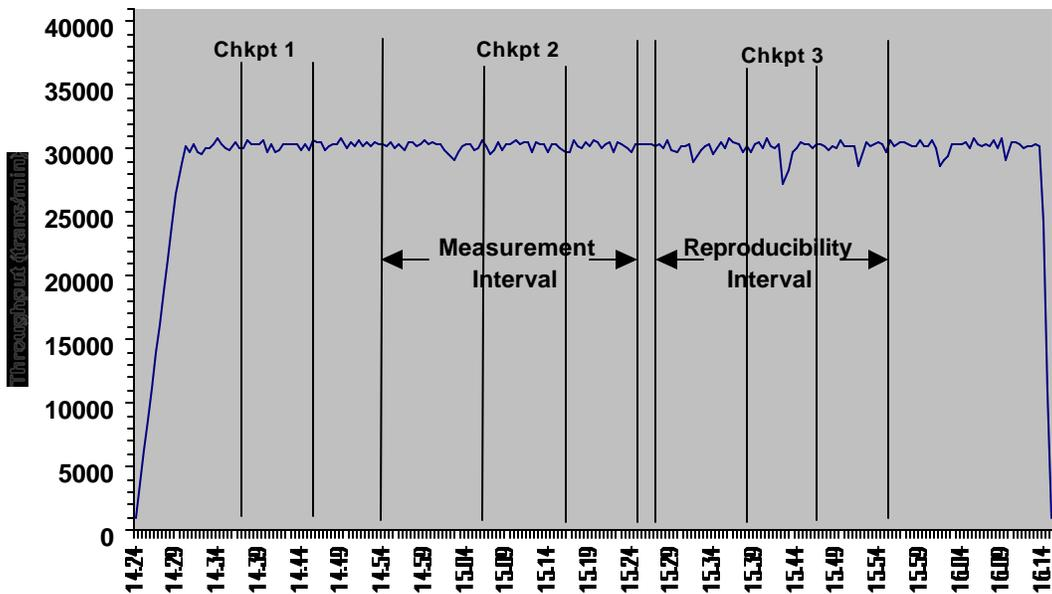

## **Steady-State Methodology**

*The method used to determine that the SUT had reached a steady state prior to commencing the measurement interval (see Clause 5.5) must be described. (8.1.6.9)*

Steady state was determined using real time monitor utilities from both the operating system and the RTE. Steady state was further confirmed by the throughput data collected during the run and graphed in Figure 10.

## **Work Performed During Steady State**

*A description of how the work normally performed during a sustained test (for example checkpointing, writing redo/undo log records, etc.), actually occurred during the measurement interval must be reported. (8.1.6.10)*

The RTE generated the required input data to choose a transaction from the menu. This data was timestamped. The menu response for the requested transaction was verified and timestamped in the RTE log files.

The RTE generated the required input data for the chosen transaction. It waited to complete the minimum required key time before transmitting the HTTP request to the client. The transmission was timestamped. The return of the screen with the required response data was timestamped. The difference between these two timestamps was the response time for that transaction and was logged in the RTE log.

The RTE then waited the required think time interval before repeating the process starting at selecting another transaction from the menu.

The RTE transmissions were sent to the web-based application program running on the client machines through Ethernet LANs. These web clients managed the emulated web browser interface as well as all requests to the database on the server. The applications communicated with the database server over another Ethernet LAN using the COM+ transaction monitor and Microsoft SQL Server DBLIB library and RPC calls.

To perform checkpoints at specific intervals, we set SQL Server *recovery interval* to the maximum allowable value and wrote a script to schedule multiple checkpoints at specific intervals. By setting the TRACE FLAG #3502, SQL Server logged the checkpoint beginning and ending time in the ERRORLOG file. The script included a wait time between each checkpoint equal to the measurement interval, which was 30 minutes. The checkpoint script was started manually after the RTE had all users logged in and sending transactions.

At each checkpoint, Microsoft SQL Server wrote to disk all memory pages that had been updated but not yet physically written to disk. Upon completion of the checkpoint, Microsoft SQL Server wrote a special record to the recovery log to indicate that all disk operations had been satisfied to this point. The positioning of the checkpoint was verified to be clear of the guard zones and is depicted on the graph in Figure 8.

## **Reproducibility Methodology**

*A description of the method used to determine the reproducibility of the measurement results must be reported. (8.1.6.11)*

The RTE master program was invoked with the configuration file shown in **Appendix C - Tunable Parameters** and the number of users logged in and issuing transactions was ramped up from 0 to 24,320 over 5 minutes. We allowed the database to warm up and to reach a steady state for an additional 30 minutes, including one checkpoint. The steady state was sustained for a 30-minute performance interval, including a checkpoint, followed 30 seconds later by a 30-minute reproducibility interval. Twenty nine minutes later a command was issued to the RTE to stop issuing transactions and the users were logged out of the web server. The reproducibility interval throughput was within 0.47% of that of the performance interval

## **Measurement Interval**

*A statement of the duration of the measurement interval for the reported Maximum Qualified Throughput (tpmC) must be included. (8.1.6.12)*

The measurement interval was 30 minutes.

## **Transaction Mix**

*8.1.6.13 The method of regulation of the transaction mix (e.g., card decks or weighted random distribution) must be described. If weighted distribution is used and the RTE adjusts the weights associated with each transaction type, the maximum adjustments to the weight from the initial value must be disclosed. (8.1.6.13)*

The RTE was given a weighted random distribution that was not adjusted during the run.

*The percentage of the total mix for each transaction type must be disclosed. (8.1.6.14)*

**Table 9: Transaction Mix**

<b>Transaction</b>	<b>Percentage</b>
New Order	44.84%
Payment	43.02%
Order Status	4.04%
Delivery	4.05%
Stock Level	4.05%

## **Other Metrics**

*The percentage of New-Order transactions rolled back as a result of invalid item number must be disclosed. (8.1.6.15)*

*The average number of order-lines entered per New-Order transaction must be disclosed.*

(8.1.6.16)

The percentage of remote order-lines entered per New-Order transaction must be disclosed.

(8.1.6.17)

The percentage of remote Payment transactions must be disclosed. (8.1.6.18)

The percentage of customer selections by customer last name in the Payment and Order-Status transactions must be disclosed. (8.1.6.19)

The percentage of Delivery transactions skipped due to there being fewer than necessary orders in the New-Order table must be disclosed. (8.1.6.20)

**Table 10: Transaction Statistics**

<b>Transaction</b>	<b>Function</b>	<b>Value</b>
New Order	Home Warehouse Items	99.00%
	Remote Warehouse Items	1.00%
	Rolled Back Transactions	0.99%
	Average Lines Per Order	10.00
Payment	Home Warehouse	84.94%
	Remote Warehouse	15.06%
	Non-Primary Key Access	60.03%
Order Status	Non-Primary Key Access	60.20%
Delivery	Skipped Transactions	0

### **Checkpoints**

The number of checkpoints in the Measurement Interval, the time in seconds from the start of the Measurement Interval to the first checkpoint and the Checkpoint Interval must be disclosed.

(8.1.6.21)

There was 1 checkpoint in the measurement interval. It started 744 sec after the start of the measurement interval. The checkpoint in the measurement interval lasted 600 seconds.

## Clause 6 -- SUT, Driver, and Communication Definition Related Items

---

### **RTE Parameters**

*The RTE input parameters, code fragments, functions, etc. used to generate each transaction input field must be disclosed. (8.1.7.1)*

**Comment:** *The intent is to demonstrate the RTE was configured to generate transaction input data as specified in Clause 2.*

The RTE input parameters are listed in Appendix C - Tunable Parameters.

### **Emulated Components**

*It must be demonstrated that the functionality and performance of the components being emulated in the Driver System are equivalent to that of the priced system. The results of the test described in Clause 6.6.3.4 must be disclosed. (8.1.7.2)*

No components were emulated.

### **Benchmarked and Targeted System Configuration Diagrams**

*A complete functional diagram of both the benchmark configuration and the configuration of the proposed (target) system must be disclosed. A detailed list of all software and hardware functionality being performed on the Driver System, and its interface to the SUT must be disclosed (see Clause 6.6.3.6). (8.1.7.3)*

The driver system performed transaction data generation and communication to the client through the standard web browser (HTTP) protocol. It also captured and timestamped the SUT output data for post-processing of the reported metrics. No other functionality was included on the driver system.

Figures 1 & 2 of this report contain detailed diagrams of both the benchmark configuration and the priced configuration.

### **Network Configuration**

*The network configurations of both the tested services and the proposed (target) services which are being represented and a thorough explanation of exactly which parts of the proposed configuration are being replaced with the Driver System must be disclosed (see Clause 6.6.4). (8.1.7.4)*

The network configurations of the benchmarked and priced configurations were identical.

### **Network Bandwidth**

*The bandwidth of the network(s) used in the tested/priced configuration must be disclosed. (8.1.7.5)*

The bandwidth of the tested and priced networks were as follows:

- 10 BaseT (10 Mbit/sec) network segments between the RTE/Emulated Users and the switch.
- 100 BaseT (100 Mbit/sec) between the Clients and Server.

### **Operator Intervention**

*If the configuration requires operator intervention (see Clause 6.6.6), the mechanism and the frequency of this intervention must be disclosed. (8.1.7.6)*

This configuration does not require any operator intervention to sustain eight hours of the reported throughput.

## Clause 7 -- Pricing Related Items

---

### **Hardware and Software List**

*A detailed list of hardware and software used in the priced system must be reported. Each separately orderable item must have vendor part number, description, and release/revision level, and either general availability status or committed delivery date. If package-pricing is used, vendor part number of the package and a description uniquely identifying each of the components of the package must be disclosed.*

*Pricing source(s) and effective date(s) of price(s) must also be reported. (8.1.8.1)*

*The total 5-year price of the entire configuration must be reported, including: hardware, software, and maintenance charges. Separate component pricing is recommended. The basis of all discounts used must be disclosed. (8.1.8.2)*

The details of the hardware and software are reported in the front of this report as part of the executive summary. All third party quotations are included at the end of this report as Appendix E.

### **Availability Date**

*The committed delivery date for general availability (availability date) of products used in the price calculations must be reported. When the priced system includes products with different availability dates, the reported availability date for the priced system must be the date at which all components are committed to be available. (8.1.8.3)*

Hardware Availability Date: Oct 23, 2000  
Software Availability Date: Oct 23, 2000

### **Measured TpmC**

*A statement of the measured tpmC, as well as the respective calculations for 5-year pricing, price/performance (price/tpmC), and the availability date must be included. (8.1.8.4)*

Maximum Qualified Throughput: 30,231.37 tpmC  
Price Performance Metric: \$6.98

### **Country Specific Pricing**

*Additional Clause 7 related items may be included in the Full Disclosure Report for each country specific priced configuration. Country specific pricing is subject to Clause 7.1.7. (8.1.8.5)*

This system is priced for the United States of America.

### **Usage Pricing**

*For any usage pricing, the sponsor must disclose (8.1.8.6):*

- *Usage level at which the component was priced.*
- *A statement of the company policy allowing such pricing.*

**Comment:** *Usage pricing may include, but is not limited to, the operating system and database management software.*

The component pricing based on usage is shown below:

- 4 Microsoft Windows 2000 Server Licenses
- 1 Microsoft Windows 2000 Advanced Server License
- 1 Microsoft SQL Server 2000 Enterprise Edition License.
- 1 Microsoft Visual C++ 32 bit Edition
- 5 Year Support for Hardware Components.

### **System Pricing**

*System pricing should include subtotals for the following components: Server Hardware, Server Software, Client Hardware, Client Software, and Network Components used for terminal connection (see Clause 7.2.2.3). Clause 6.1 describes the Server and Client components. An example of the standard pricing sheet is shown in Appendix B. (8.1.8.7)*

*System pricing must include line item indication where non-sponsoring companies' brands are used. System pricing must also include line item indication of third party pricing. See example in Appendix B. (8.1.8.8)*

The details of the hardware and software are reported in the front of this report as part of the executive summary. All third party quotations are included at the end of this report as Appendix E.

## Clause 9 -- Audit Related Items

---

### **Auditor**

*The auditor's name, address, phone number, and a copy of the auditor's attestation letter indicating compliance must be included in the Full Disclosure Report. (8.1.9.1)*

*A review of the pricing model is required to ensure that all components required are priced (see Clause 9.2.8). The auditor is not required to review the final Full Disclosure Report or the final pricing prior to issuing the attestations letter. (8.1.9.2)*

This TPC-C benchmark has been audited by Tom Sawyer of Performance Metrics.

### **Availability of the Full Disclosure Report**

*The Full Disclosure Report must be readily available to the public at a reasonable charge, similar to the charges for similar documents by the test sponsor. The report must be made available when results are made public. In order to use the phrase "TPC Benchmark™ C", the Full Disclosure Report must have been submitted to the TPC Administrator as well as written permission obtained to distribute same.*

Requests for this TPC Benchmark C Full Disclosure Report should be sent to:

Transaction Processing Performance Council  
c/o Shanley Public Relations  
777 North First Street, Suite 6000  
San Jose, CA 95112-6311  
[www.tpc.org](http://www.tpc.org)

or:

Dell  
One Dell Way  
Round Rock, TX 78682  
Attention: Mike Molloy

March 16, 2001

Mike Molloy  
Manager, Enterprise Systems Performance  
Dell  
One Dell Way  
Round Rock, TX 78682

In my opinion, the data provided for the PowerEdge 6450 result of October 26, 2000 complies with the TPC-C Version 5 upgrade requirements.

The following attributes of the benchmark were given special attention:

- The data for the 60 day space calculation was verified. Four 18Gb drive were removed from the original configuration – they were added to satisfy the 180-day space requirement.
- Maintenance was verified to be 3-year, 7 X 24.
- The system pricing was checked for major components and maintenance.

Auditor Notes:

The Dell PowerEdge 1300 client systems were replaced by Dell PowerEdge 1400 systems per TAB decision of March 12, 2001. The price is the 1400 price which is higher than the last published 1300 price.

Sincerely,

Tom Sawyer



Auditor

## Auditor's Letter of Attestation

October 19, 2000

Mike Molloy  
Manager, Enterprise Systems Performance  
Dell  
One Dell Way  
Round Rock, TX 78682

I have verified the TPC Benchmark™ C client/server for the following configuration:

Platform: Dell PowerEdge 6450 Server  
Database Manager: Microsoft SQL Server 2000 Enterprise Edition (Version 8.0)  
Operating System:  
    Server: Microsoft Windows 2000 Advanced Server  
    Clients: Microsoft Windows 2000 Server  
Transaction Manager: Microsoft COM+

Server: Dell PowerEdge 6450 Server				
CPU's	Memory	Disks	90% Response	tpmC
4 Pentium III Xeon @ 700 MHz	Main: 8 GB Cache: 2MB	1 @ 9 GB 118 @ 18 GB	<b>0.86 sec</b>	<b>30,231.37</b>
4 Clients: Dell PowerEdge 1300 (each)				
1 Pentium III 3 clients @600MHz 1 clients @550MHz	Main: 512 MB Cache: 512 KB	1 @ 9 GB	Na	Na

In my opinion, these performance results were produced in compliance with the TPC requirements for the benchmark. The following attributes of the benchmark were given special attention:

- The transactions were correctly implemented.
- The database files were properly sized and populated.
- The database was properly scaled with 2,450 warehouses. The measurement used 2,432 warehouses; I verified that d\_next\_o\_id and w\_ytd did not change for the unused warehouses
- The ACID properties were met.

- The Durability tests for loss-of-log and loss-of-data disks were performed on a 10-warehouse system.
- Input data was generated according to the specified percentages.
- Eight hours of mirrored log space was present on the tested system.
- Eight hours of growth space for the dynamic tables was present on the tested system.
- The data for the 180 day space calculation was verified – 4 18GB drives were added to the priced configuration.
- The steady state portion of the test was 30 minutes.
- One checkpoint was taken before the measured interval.
- One checkpoint was taken during the measured interval.
- The checkpoints were verified to be clear of the guard zone.
- The system pricing was checked for major components and maintenance.

Auditor Notes:

none

Sincerely,

Tom Sawyer

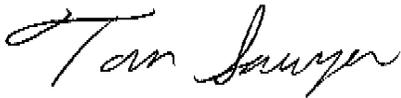
A handwritten signature in black ink that reads "Tom Sawyer". The signature is written in a cursive, flowing style.

Auditor

# Appendix A - Application Source Code

## Appendix A - Application Source Code

### tpcc.dll ISAPI DLL Source Code

#### isapi\_dll/src/tpcc.def

```
LIBRARY TPCC.DLL

EXPORTS

    GetExtensionVersion@1
    HttpExtensionProc @2
    TerminateExtension @3
```

#### Isapi\_dll/src/tpcc.h

```
/*      FILE:          TPCC.H
 *
 *      Microsoft TPC-C Kit Ver. 4.20.000
 *      Copyright Microsoft, 1999
 *
 *      All Rights Reserved
 *
 *      Version 4.10.000 audited by Richard Gimarc,
 *      Performance Metrics, 3/17/99
 *
 *      PURPOSE:  Header file for ISAPI TPCC.DLL, defines structures and functions used
 *      in the isapi tpcc.dll.
 */

//VERSION RESOURCE DEFINES
#define _APS_NEXT_RESOURCE_VALUE        101
#define _APS_NEXT_COMMAND_VALUE        40001
#define _APS_NEXT_CONTROL_VALUE        1000
#define _APS_NEXT_SYMED_VALUE          101

#define TP_MAX_RETRIES
    50

//note that the welcome form must be processed first as terminal ids assigned here, once
the
//terminal id is assigned then the forms can be processed in any order.
#define WELCOME_FORM                    1
    //beginning form no term id assigned, form id
```

```
#define MAIN_MENU_FORM                  2
    //term id assigned main menu form id
#define NEW_ORDER_FORM                  3
    //new order form id
#define PAYMENT_FORM                    4
    //payment form id
#define DELIVERY_FORM                   5
    //delivery form id
#define ORDER_STATUS_FORM                6
    //order status id
#define STOCK_LEVEL_FORM                 7
    //stock level form id

//This macro is used to prevent the compiler error unused formal parameter
#define UNUSEDPARAM(x) (x = x)

//This structure defines the data necessary to keep distinct for each terminal or client
connection.
typedef struct _CLIENTDATA
{
    int                iNextFree;
    //index of next free element or -1 if this entry in use.
    int                w_id;
    //warehouse id assigned at welcome form
    int                d_id;
    //district id assigned at welcome form

    int                iSyncId;
    //synchronization id
    int                iTickCount;
    //time of last access;

    CTPCC_BASE        *pTxn;
} CLIENTDATA, *PCLIENTDATA;

//This structure is used to define the operational interface for terminal id support
typedef struct _TERM
{
    int                iNumEntries;
    //total allocated terminal array entries
    int                iFreeList;
    //next available terminal array element or -1 if none
    int                iMasterSyncId;
    //synchronization id
    CLIENTDATA        *pClientData;
    //pointer to allocated client data
} TERM;

typedef TERM *PTERM;
    //pointer to terminal structure type

enum WEBERROR
{
    NO_ERR,
    ERR_COMMAND_UNDEFINED,
    ERR_D_ID_INVALID,
    ERR_DELIVERY_CARRIER_ID_RANGE,
    ERR_DELIVERY_CARRIER_INVALID,
    ERR_DELIVERY_MISSING_OCD_KEY,
```

## Appendix A - Application Source Code

```
ERR_DELIVERY_THREAD_FAILED,
ERR_GETPROCADDR_FAILED,
ERR_HTML_ILL_FORMED,
ERR_INVALID_SYNC_CONNECTION,
ERR_INVALID_TERMID,
ERR_LOADDLL_FAILED,
ERR_MAX_CONNECTIONS_EXCEEDED,
ERR_MEM_ALLOC_FAILED,
ERR_MISSING_REGISTRY_ENTRIES,
ERR_NEWORDER_CUSTOMER_INVALID,
ERR_NEWORDER_CUSTOMER_KEY,
ERR_NEWORDER_DISTRICT_INVALID,
ERR_NEWORDER_FORM_MISSING_DID,
ERR_NEWORDER_ITEMID_INVALID,
ERR_NEWORDER_ITEMID_RANGE,
ERR_NEWORDER_ITEMID_WITHOUT_SUPPW,
ERR_NEWORDER_MISSING_IID_KEY,
ERR_NEWORDER_MISSING_QTY_KEY,
ERR_NEWORDER_MISSING_SUPPW_KEY,
ERR_NEWORDER_NOITEMS_ENTERED,
ERR_NEWORDER_QTY_INVALID,
ERR_NEWORDER_QTY_RANGE,
ERR_NEWORDER_QTY_WITHOUT_SUPPW,
ERR_NEWORDER_SUPPW_INVALID,
ERR_NO_SERVER_SPECIFIED,
ERR_ORDERSTATUS_CID_AND_CLT,
ERR_ORDERSTATUS_CID_INVALID,
ERR_ORDERSTATUS_CLT_RANGE,
ERR_ORDERSTATUS_DID_INVALID,
ERR_ORDERSTATUS_MISSING_CID_CLT,
ERR_ORDERSTATUS_MISSING_CID_KEY,
ERR_ORDERSTATUS_MISSING_CLT_KEY,
ERR_ORDERSTATUS_MISSING_DID_KEY,
ERR_PAYMENT_CDI_INVALID,
ERR_PAYMENT_CID_AND_CLT,
ERR_PAYMENT_CUSTOMER_INVALID,
ERR_PAYMENT_CWI_INVALID,
ERR_PAYMENT_DISTRICT_INVALID,
ERR_PAYMENT_HAM_INVALID,
ERR_PAYMENT_HAM_RANGE,
ERR_PAYMENT_LAST_NAME_TO_LONG,
ERR_PAYMENT_MISSING_CDI_KEY,
ERR_PAYMENT_MISSING_CID_CLT,
ERR_PAYMENT_MISSING_CID_KEY,
ERR_PAYMENT_MISSING_CLT,
ERR_PAYMENT_MISSING_CLT_KEY,
ERR_PAYMENT_MISSING_CWI_KEY,
ERR_PAYMENT_MISSING_DID_KEY,
ERR_PAYMENT_MISSING_HAM_KEY,
ERR_STOCKLEVEL_MISSING_THRESHOLD_KEY,
ERR_STOCKLEVEL_THRESHOLD_INVALID,
ERR_STOCKLEVEL_THRESHOLD_RANGE,
ERR_VERSION_MISMATCH,
ERR_W_ID_INVALID
};

class CWEBCLNT_ERR : public CBaseErr
{
public:
    CWEBCLNT_ERR(WEBERROR Err)
    {
        m_Error = Err;
        m_szTextDetail = NULL;
        m_SystemErr = 0;
        m_szErrorText = NULL;
    };

    CWEBCLNT_ERR(WEBERROR Err, char *szTextDetail, DWORD dwSystemErr)
    {
        m_Error = Err;
        m_szTextDetail = new char[strlen(szTextDetail)+1];
        strcpy( m_szTextDetail, szTextDetail );
        m_SystemErr = dwSystemErr;
        m_szErrorText = NULL;
    };

    ~CWEBCLNT_ERR()
    {
        if (m_szTextDetail != NULL)
            delete [] m_szTextDetail;
        if (m_szErrorText != NULL)
            delete [] m_szErrorText;
    };

    WEBERROR m_Error;
    char *m_szTextDetail; //
    char *m_szErrorText;
    DWORD m_SystemErr;

    int ErrorType() {return ERR_TYPE_WEBDLL;};
    int ErrorNum() {return m_Error;};
    char *ErrorText();
};

//These constants have already been defined in engstut.h, but since we do
//not want to include it in the delisrv executable
#define TXN_EVENT_START 2
#define TXN_EVENT_STOP 4
#define TXN_EVENT_WARNING 6 //used to record a warning into the log

//function prototypes
BOOL APIENTRY DllMain(HANDLE hModule, DWORD ul_reason_for_call, LPVOID lpReserved);
void WriteMessageToEventLog(LPTSTR lpszMsg);
void ProcessQueryString(EXTENSION_CONTROL_BLOCK *pECB, int *pCmd, int *pFormId, int *pTermId, int *pSyncId);
void WelcomeForm(EXTENSION_CONTROL_BLOCK *pECB, char *szBuffer);
void SubmitCmd(EXTENSION_CONTROL_BLOCK *pECB, char *szBuffer);
void BeginCmd(EXTENSION_CONTROL_BLOCK *pECB, int iFormId, int iTermId);
void ProcessCmd(EXTENSION_CONTROL_BLOCK *pECB, int iFormId, int iTermId);
void StatsCmd(EXTENSION_CONTROL_BLOCK *pECB, char *szBuffer);
void ErrorMessage(EXTENSION_CONTROL_BLOCK *pECB, int iError, int iErrorType, char *szMsg, int iTermId);
void GetKeyValue(char **pQueryString, char *pKey, char *pValue, int iMax, WEBERROR err);
int GetIntKeyValue(char **pQueryString, char *pKey, WEBERROR NoKeyErr, WEBERROR NotIntErr);
void TermInit(void);
void TermDeleteAll(void);
int TermAdd(void);
void TermDelete(int id);
void ErrorForm(EXTENSION_CONTROL_BLOCK *pECB, int iType, int iErrorNum, int iTermId, int iSyncId, char *szErrorText, char *szBuffer );
void MakeMainMenuForm(int iTermId, int iSyncId, char *szForm);
```

# Appendix A - Application Source Code

```
void MakeStockLevelForm(int iTermId, STOCK_LEVEL_DATA *pStockLevelData, BOOL bInput, char *szForm);
void MakeNewOrderForm(int iTermId, NEW_ORDER_DATA *pNewOrderData, BOOL bInput, char *szForm);
void MakePaymentForm(int iTermId, PAYMENT_DATA *pPaymentData, BOOL bInput, char *szForm);
void MakeOrderStatusForm(int iTermId, ORDER_STATUS_DATA *pOrderStatusData, BOOL bInput, char *szForm);
void MakeDeliveryForm(int iTermId, DELIVERY_DATA *pDeliveryData, BOOL bInput, char *szForm);
void ProcessNewOrderForm(EXTENSION_CONTROL_BLOCK *pECB, int iTermId, char *szBuffer);
void ProcessPaymentForm(EXTENSION_CONTROL_BLOCK *pECB, int iTermId, char *szBuffer);
void ProcessOrderStatusForm(EXTENSION_CONTROL_BLOCK *pECB, int iTermId, char *szBuffer);
void ProcessDeliveryForm(EXTENSION_CONTROL_BLOCK *pECB, int iTermId, char *szBuffer);
void ProcessStockLevelForm(EXTENSION_CONTROL_BLOCK *pECB, int iTermId, char *szBuffer);
void GetNewOrderData(LPSTR lpszQueryString, NEW_ORDER_DATA *pNewOrderData);
void GetPaymentData(LPSTR lpszQueryString, PAYMENT_DATA *pPaymentData);
void GetOrderStatusData(LPSTR lpszQueryString, ORDER_STATUS_DATA *pOrderStatusData);
BOOL PostDeliveryInfo(short w_id, short o_carrier_id);
BOOL IsNumeric(char *ptr);
BOOL IsDecimal(char *ptr);
void DeliveryWorkerThread(void *ptr);
```

## isapi\_dll/src/tpcc.rc

```
//Microsoft Developer Studio generated resource script.
//
#include "resource.h"

#define APSTUDIO_READONLY_SYMBOLS
//
// Generated from the TEXTINCLUDE 2 resource.
//
#include "afxres.h"

//
// English (U.S.) resources
//

#if !defined(AFX_RESOURCE_DLL) || defined(AFX_TARG_ENU)
#ifdef _WIN32
LANGUAGE LANG_ENGLISH, SUBLANG_ENGLISH_US
#pragma code_page(1252)
#endif // _WIN32

#ifdef _MAC
//
// Version
//

VS_VERSION_INFO VERSIONINFO
FILEVERSION 0,4,0,0
PRODUCTVERSION 0,4,0,0
FILEFLAGSMASK 0x3fL
#ifdef _DEBUG
FILEFLAGS 0x1L
```

```
#else
FILEFLAGS 0x0L
#endif
FILEOS 0x40004L
FILETYPE 0x2L
FILESUBTYPE 0x0L
BEGIN
BLOCK "StringFileInfo"
BEGIN
BLOCK "040904b0"
BEGIN
VALUE "Comments", "TPC-C HTML DLL Server (DBLIB)\0"
VALUE "CompanyName", "Microsoft\0"
VALUE "FileDescription", "TPC-C HTML DLL Server (DBLIB)\0"
VALUE "FileVersion", "0, 4, 0, 0\0"
VALUE "InternalName", "tpcc\0"
VALUE "LegalCopyright", "Copyright © 1997\0"
VALUE "OriginalFilename", "tpcc.dll\0"
VALUE "ProductName", "Microsoft tpcc\0"
VALUE "ProductVersion", "0, 4, 0, 0\0"
END
END
BLOCK "VarFileInfo"
BEGIN
VALUE "Translation", 0x409, 1200
END
END

#endif // !_MAC

#ifdef APSTUDIO_INVOKED
//
// TEXTINCLUDE
//

1 TEXTINCLUDE DISCARDABLE
BEGIN
"resource.h\0"
END

2 TEXTINCLUDE DISCARDABLE
BEGIN
#include "afxres.h"\r\n
"\0"
END

3 TEXTINCLUDE DISCARDABLE
BEGIN
"\r\n"
"\0"
END

#endif // APSTUDIO_INVOKED

//
// Dialog
//

IDD_DIALOG1 DIALOG DISCARDABLE 0, 0, 186, 95
```

# Appendix A - Application Source Code

```
STYLE DS_MODALFRAME | WS_POPUP | WS_CAPTION | WS_SYSMENU
CAPTION "Dialog"
FONT 8, "MS Sans Serif"
BEGIN
    DEFPUSHBUTTON   "OK", IDOK, 129, 7, 50, 14
    PUSHBUTTON     "Cancel", IDCANCEL, 129, 24, 50, 14
END

////////////////////////////////////
//
// DESIGNINFO
//

#ifdef APSTUDIO_INVOKED
GUIDELINES DESIGNINFO DISCARDABLE
BEGIN
    IDD_DIALOG1, DIALOG
    BEGIN
        LEFTMARGIN, 7
        RIGHTMARGIN, 179
        TOPMARGIN, 7
        BOTTOMMARGIN, 88
    END
END
#endif // APSTUDIO_INVOKED

// English (U.S.) resources
////////////////////////////////////

#ifndef APSTUDIO_INVOKED
////////////////////////////////////
//
// Generated from the TEXTINCLUDE 3 resource.
//

////////////////////////////////////
#endif // not APSTUDIO_INVOKED

isapi_dll/src/tpcc.cpp

/*      FILE:          TPCC.C
 *
 *      Microsoft TPC-C Kit Ver. 4.20.000
 *      Copyright Microsoft, 1999
 *
 *      All Rights Reserved
 *
 *      Version 4.10.000 audited by Richard Gimarc,
 *      Performance Metrics, 3/17/99
 *
 *      PURPOSE:  Main module for TPCC.DLL which is an ISAPI service dll.
 *      Contact:  Charles Levine (clevine@microsoft.com)
 *
 *      Change history:
 *      4.20.000 - reworked error handling; added options for COM and Encina
 *      txn monitors
 */
```

```
*/
#include <windows.h>
#include <process.h>
#include <tchar.h>
#include <stdio.h>
#include <stdarg.h>
#include <malloc.h>
#include <stdlib.h>
#include <string.h>
#include <time.h>
#include <sys\timeb.h>
#include <io.h>
#include <assert.h>

#include <sqltypes.h>

#ifdef ICECAP
#include <icapexp.h>
#endif

#include "..\..\common\src\trans.h" //tpckit transaction header contains
definitions of structures specific to TPC-C
#include "..\..\common\src\error.h"
#include "..\..\common\src\txn_base.h"
#include "..\..\common\src\ReadRegistry.h"

#include "..\..\common\txnlog\include\rtetime.h"
#include "..\..\common\txnlog\include\spinlock.h"
#include "..\..\common\txnlog\include\txnlog.h"

// Database layer includes
#include "..\..\db_dblib_dll\src\tpcc_dblib.h" // DBLIB implementation of
TPC-C txns
#include "..\..\db_odbc_dll\src\tpcc_odbc.h" // ODBC implementation of
TPC-C txns

// Txn monitor layer includes
#include "..\..\tm_com_dll\src\tpcc_com.h" // COM Services
implementation on TPC-C txns
#include "..\..\tm_tuxedo_dll\src\tpcc_tux.h" // interface to Tuxedo
libraries
#include "..\..\tm_encina_dll\src\tpcc_enc.h" // interface to Encina
libraries

#include "httpext.h" //ISAPI DLL information
header
#include "tpcc.h" //this dlls specific
structure, value e.t. header.

#define LEN_ERR_STRING 256

// defines for Make<Txn>Form calls to distinguish input and output flavors
#define OUTPUT_FORM 0
#define INPUT_FORM 1

char szMyComputerName[MAX_COMPUTERNAME_LENGTH+1];

//Terminal client id structure
TERM Term = { 0, 0, 0, NULL };

// The WEBCLIENT_VERSION string specifies the version level of this web client interface.
```

## Appendix A - Application Source Code

```
// The RTE must be synchronized with the interface level on login, otherwise the login
// will fail. This is a sanity check to catch problems resulting from mismatched
versions
// of the RTE and web client.
#define WEBCCLIENT_VERSION "410"

static CRITICAL_SECTION TermCriticalSection;

static HINSTANCE hLibInstanceTm = NULL;
static HINSTANCE hLibInstanceDb = NULL;

TYPE_CTPCC_DBLIB *pCTPCC_DBLIB_new;
TYPE_CTPCC_ODBC *pCTPCC_ODBC_new;
TYPE_CTPCC_TUXEDO *pCTPCC_TUXEDO_new;
TYPE_CTPCC_ENCINA *pCTPCC_ENCINA_new;
TYPE_CTPCC_ENCINA *pCTPCC_ENCINA_post_init;
TYPE_CTPCC_COM *pCTPCC_COM_new;

// For deferred Delivery txns:

CTxnLog //used to log delivery transaction information *txnDelilog = NULL;

HANDLE hWorkerSemaphore =
INVALID_HANDLE_VALUE;
HANDLE hDoneEvent
= INVALID_HANDLE_VALUE;
HANDLE *pDeliHandles = NULL;

// configuration settings from registry
TPCCREGISTRYDATA Reg;

DWORD dwNumDeliveryThreads = 4;
CRITICAL_SECTION DelBuffCriticalSection; //critical section
for delivery transactions cache
DELIVERY_TRANSACTION *pDelBuff = NULL;
DWORD dwDelBuffSize = 100;
// size of circular buffer for delivery txns
DWORD dwDelBuffFreeCount;
// number of buffers free
DWORD dwDelBuffBusyIndex = 0;
// index position of entry waiting to be delivered
DWORD dwDelBuffFreeIndex = 0;
// index position of unused entry

#include "..\..\common\src\ReadRegistry.cpp"

/* FUNCTION: DllMain
 *
 * PURPOSE: This function is the entry point for the DLL. This implementation is
based on the fact that DLL_PROCESS_ATTACH is only called from the inet
service once.
 *
 * ARGUMENTS: HANDLE hModule module handle
 * DWORD ul_reason_for_call reason for call
 * LPVOID lpReserved reserved for future use
 *
 * RETURNS: BOOL FALSE errors
occured in initialization
```

```
* TRUE
DLL successfully initialized
*/
BOOL APIENTRY DllMain(HANDLE hModule, DWORD ul_reason_for_call, LPVOID lpReserved)
{
    DWORD i;
    char szEvent[LEN_ERR_STRING] = "\0";
    char szLogFile[128];
    char szDllName[128];

    // debugging...
    // DebugBreak();

    try
    {
        switch( ul_reason_for_call )
        {
            case DLL_PROCESS_ATTACH:
            {
                DWORD dwSize =
MAX_COMPUTERNAME_LENGTH+1;
                GetComputerName(szMyComputerName,
&dwSize);
                szMyComputerName[dwSize] = 0;

                DisableThreadLibraryCalls( (HMODULE)hModule);
                InitializeCriticalSection(&TermCriticalSection);

                if ( ReadTPCCRegistrySettings( &Reg ) )
                    throw new CWEBCLNT_ERR(
ERR_MISSING_REGISTRY_ENTRIES );

                dwDelBuffSize = min( Reg.dwMaxPendingDeliveries,
10000 ); // min with 10000 as a sanity constraint
                dwNumDeliveryThreads = min(
Reg.dwNumberOfDeliveryThreads, 100 ); // min with 100 as a sanity constraint

                TermInit();

                // load DLL for txn monitor
                if (Reg.eTxnMon == TUXEDO)
                {
                    strcpy( szDllName, Reg.szPath );
                    strcat( szDllName, "tpcc_tuxedo.dll");
                    hLibInstanceTm = LoadLibrary( szDllName );

                    if (hLibInstanceTm == NULL)
                        throw new CWEBCLNT_ERR(
ERR_LOADDLL_FAILED, szDllName, GetLastError() );

                    // get function pointer to wrapper for
                    class constructor
                    pCTPCC_TUXEDO_new =
(TYPE_CTPCC_TUXEDO*) GetProcAddress(hLibInstanceTm, "CTPCC_TUXEDO_new");
                    if (pCTPCC_TUXEDO_new == NULL)
                        throw new CWEBCLNT_ERR(
ERR_GETPROCADDR_FAILED, szDllName, GetLastError() );
                }
                else if (Reg.eTxnMon == ENCINA)
                {
                    strcpy( szDllName, Reg.szPath );
                }
            }
        }
    }
}
```

## Appendix A - Application Source Code

```
);
    strcat( szDllName, "tpcc_encina.dll");
    hLibInstanceTm = LoadLibrary( szDllName
);
    if (hLibInstanceTm == NULL)
        throw new CWEBCLNT_ERR(
ERR_LOADDLL_FAILED, szDllName, GetLastError() );
// get function pointer to wrapper for
class constructor
    pCTPCC_ENCINA_new =
(TYPE_CTPCC_ENCINA*) GetProcAddress(hLibInstanceTm, "CTPCC_ENCINA_new");
    pCTPCC_ENCINA_post_init =
(TYPE_CTPCC_ENCINA*) GetProcAddress(hLibInstanceTm, "CTPCC_ENCINA_post_init");
    if (pCTPCC_ENCINA_new == NULL)
        throw new CWEBCLNT_ERR(
ERR_GETPROCADDR_FAILED, szDllName, GetLastError() );
    }
    else if (Reg.eTxnMon == COM)
    {
        strcpy( szDllName, Reg.szPath );
        strcat( szDllName, "tpcc_com.dll");
        hLibInstanceTm = LoadLibrary( szDllName
);
        if (hLibInstanceTm == NULL)
            throw new CWEBCLNT_ERR(
ERR_LOADDLL_FAILED, szDllName, GetLastError() );
// get function pointer to wrapper for
class constructor
    pCTPCC_COM_new = (TYPE_CTPCC_COM*)
GetProcAddress(hLibInstanceTm, "CTPCC_COM_new");
    if (pCTPCC_COM_new == NULL)
        throw new CWEBCLNT_ERR(
ERR_GETPROCADDR_FAILED, szDllName, GetLastError() );
    }
// load DLL for database connection
if ((Reg.eTxnMon == None) ||
(dwNumDeliveryThreads > 0))
    {
        if (Reg.eDB_Protocol == DBLIB)
        {
            strcpy( szDllName, Reg.szPath
);
            strcat( szDllName,
"tpcc_dblib.dll");
            szDllName );
            hLibInstanceDb = LoadLibrary(
            if (hLibInstanceDb == NULL)
                throw new
CWEBCLNT_ERR( ERR_LOADDLL_FAILED, szDllName, GetLastError() );
// get function pointer to
wrapper for class constructor
            pCTPCC_DBLIB_new =
(TYPE_CTPCC_DBLIB*) GetProcAddress(hLibInstanceDb, "CTPCC_DBLIB_new");
            if (pCTPCC_DBLIB_new == NULL)
                throw new
CWEBCLNT_ERR( ERR_GETPROCADDR_FAILED, szDllName, GetLastError() );
        }
        else if (Reg.eDB_Protocol == ODBC)
        {
            strcpy( szDllName, Reg.szPath
```

```

            strcat( szDllName,
"tpcc_odbc.dll");
            szDllName );
            hLibInstanceDb = LoadLibrary(
            if (hLibInstanceDb == NULL)
                throw new
CWEBCLNT_ERR( ERR_LOADDLL_FAILED, szDllName, GetLastError() );
// get function pointer to
wrapper for class constructor
            pCTPCC_ODBC_new =
(TYPE_CTPCC_ODBC*) GetProcAddress(hLibInstanceDb, "CTPCC_ODBC_new");
            if (pCTPCC_ODBC_new == NULL)
                throw new
CWEBCLNT_ERR( ERR_GETPROCADDR_FAILED, szDllName, GetLastError() );
        }
    }
    if (dwNumDeliveryThreads)
    {
        // for deferred delivery txns:
        hDoneEvent = CreateEvent( NULL, TRUE /*
manual reset */, FALSE /* initially not signalled */, NULL );
        InitializeCriticalSection(&DelBuffCriticalSection);
        hWorkerSemaphore = CreateSemaphore(
NULL, 0, dwDelBuffSize, NULL );
        dwDelBuffFreeCount = dwDelBuffSize;
        InitJulianTime(NULL);
// create unique log file name based on
SYSTEMTIME Time;
        GetLocalTime( &Time );
        wsprintf( szLogFile, "%sdelivery-
Reg.szPath,
Time.wYear % 100, Time.wMonth, Time.wDay, Time.wHour, Time.wMinute );
        txndelilog = new CTxnLog(szLogFile,
TXN_LOG_WRITE);
//write event into txn log for START
txndelilog-
>WriteCtrlRecToLog(TXN_EVENT_START, szMyComputerName, sizeof(szMyComputerName));
// allocate structures for delivery
buffers and thread mgmt
        pDeliHandles = new
HANDLE[dwNumDeliveryThreads];
        pDelBuff = new
DELIVERY_TRANSACTION[dwDelBuffSize];
// launch DeliveryWorkerThread to
perform actual delivery txns
        for(i=0; i<dwNumDeliveryThreads; i++)
        {
            pDeliHandles[i] = (HANDLE)
            if (pDeliHandles[i] ==
                throw new
CWEBCLNT_ERR( ERR_DELIVERY_THREAD_FAILED );
        }
    }
```

## Appendix A - Application Source Code

```
    }
    break;

case DLL_PROCESS_DETACH:
    if (dwNumDeliveryThreads)
    {
        if (txnDelilog != NULL)
        {
            //write event into txn log
            txnDelilog-
            >WriteCtrlRecToLog(TXN_EVENT_STOP, szMyComputerName, sizeof(szMyComputerName));

            // This will do a clean
            CTxnLog *txnDelilogLocal =
            txnDelilog= NULL;
            delete txnDelilogLocal;
        }

        delete [] pDeliHandles;
        delete [] pDelBuff;

        CloseHandle( hWorkerSemaphore );
        CloseHandle( hDoneEvent );

DeleteCriticalSection(&DelBuffCriticalSection);
    }

DeleteCriticalSection(&TermCriticalSection);

    if (hLibInstanceTm != NULL)
        FreeLibrary( hLibInstanceTm );
    hLibInstanceTm = NULL;

    if (hLibInstanceDb != NULL)
        FreeLibrary( hLibInstanceDb );
    hLibInstanceDb = NULL;

    Sleep(500);
    break;

default:
    /* nothing */;
}
}
catch (CBaseErr *e)
{
    WriteMessageToEventLog( e->ErrorText() );
    delete e;
    TerminateExtension(0);
    return FALSE;
}
catch (...)
{
    WriteMessageToEventLog(TEXT("Unhandled exception. DLL could not
load.));
    TerminateExtension(0);
    return FALSE;
}
}
```

```
    return TRUE;
}

/* FUNCTION: GetExtensionVersion
*
* PURPOSE: This function is called by the inet service when the DLL is first
loaded.
*
* ARGUMENTS: HSE_VERSION_INFO *pVer passed in structure in which to place
expected version number.
*
* RETURNS: TRUE inet service expected return value.
*/

BOOL WINAPI GetExtensionVersion(HSE_VERSION_INFO *pVer)
{
    pVer->dwExtensionVersion = MAKELONG(HSE_VERSION_MINOR, HSE_VERSION_MAJOR);
    lstrcpy(pVer->lpszExtensionDesc, "TPC-C Server.", HSE_MAX_EXT_DLL_NAME_LEN);

    // TODO: why do we need this here instead of in the DLL attach?
    if (Reg.eTxnMon == ENCINA)
        pCTPCC_ENCINA_post_init();

    return TRUE;
}

/* FUNCTION: TerminateExtension
*
* PURPOSE: This function is called by the inet service when the DLL is about to
be unloaded.
*
* Release all resources in anticipation of being unloaded.
*
* RETURNS: TRUE inet service expected return value.
*/

BOOL WINAPI TerminateExtension( DWORD dwFlags )
{
    if (pDeliHandles)
    {
        SetEvent( hDoneEvent );
        for(DWORD i=0; i<dwNumDeliveryThreads; i++)
            WaitForSingleObject( pDeliHandles[i], INFINITE );
    }

    TermDeleteAll();
    return TRUE;
}

/* FUNCTION: HttpExtensionProc
*
* PURPOSE: This function is the main entry point for the TPCC DLL. The internet
service
calls this function passing in the http string.
*
* ARGUMENTS: EXTENSION_CONTROL_BLOCK *pECB structure pointer to passed
in internet
service information.
*
* RETURNS: DWORD HSE_STATUS_SUCCESS
connection can be dropped if error
```

## Appendix A - Application Source Code

```
*
*      HSE_STATUS_SUCCESS_AND_KEEP_CONN      keep connect valid comment sent
*
* COMMENTS:      None
*
*/
DWORD WINAPI HttpExtensionProc(EXTENSION_CONTROL_BLOCK *pECB)
{
    int          iCmd, FormId, TermId, iSyncId;
    char         szBuffer[4096];

    int          lpbSize;
    static char  szHeader[] = "200 Ok";
    DWORD        dwSize = 6;          // initial value is
    strlen(szHeader)
    char         szHeader1[4096];

#ifdef ICECAP
    StartCAP();
#endif

    try
    {
        //process http query
        ProcessQueryString(pECB, &iCmd, &FormId, &TermId, &iSyncId);

        if (TermId != 0)
        {
            if ( TermId < 0 || TermId >= Term.iNumEntries ||
                Term.pClientData[TermId].iNextFree != -1 )
            {
                // debugging...
                char szTmp[128];
                wsprintf( szTmp, "Invalid term ID: TermId = %d",
                    TermId );
                WriteMessageToEventLog( szTmp );
                throw new CWEBCLNT_ERR( ERR_INVALID_TERMID );
            }

            //must have a valid syncid here since termid is valid
            if (iSyncId != Term.pClientData[TermId].iSyncId)
                throw new CWEBCLNT_ERR(
                    ERR_INVALID_SYNC_CONNECTION );

            //set use time
            Term.pClientData[TermId].iTickCount = GetTickCount();
        }

        switch(iCmd)
        {
        case 0:
            WelcomeForm(pECB, szBuffer);
            break;

        case 1:
            switch( FormId )
            {
                case WELCOME_FORM:
                case MAIN_MENU_FORM:
                    break;
            }

            case NEW_ORDER_FORM:
                ProcessNewOrderForm(pECB, TermId,
                    szBuffer);
                break;

            case PAYMENT_FORM:
                ProcessPaymentForm(pECB, TermId,
                    szBuffer);
                break;

            case DELIVERY_FORM:
                ProcessDeliveryForm(pECB, TermId,
                    szBuffer);
                break;

            case ORDER_STATUS_FORM:
                ProcessOrderStatusForm(pECB, TermId,
                    szBuffer);
                break;

            case STOCK_LEVEL_FORM:
                ProcessStockLevelForm(pECB, TermId,
                    szBuffer);
                break;
        }
    }
    catch (CWebclntErr e)
    {
        case 2:
            // new-order selected from menu; display new-order input
            form
            MakeNewOrderForm(TermId, NULL, INPUT_FORM, szBuffer);
            break;

        case 3:
            // payment selected from menu; display payment input form
            MakePaymentForm(TermId, NULL, INPUT_FORM, szBuffer);
            break;

        case 4:
            // delivery selected from menu; display delivery input form
            MakeDeliveryForm(TermId, NULL, INPUT_FORM, szBuffer);
            break;

        case 5:
            // order-status selected from menu; display order-status
            input form
            MakeOrderStatusForm(TermId, NULL, INPUT_FORM, szBuffer);
            break;

        case 6:
            // stock-level selected from menu; display stock-level
            input form
            MakeStockLevelForm(TermId, NULL, INPUT_FORM, szBuffer);
            break;

        case 7:
            // ExitCmd
            TermDelete(TermId);
            WelcomeForm(pECB, szBuffer);
            break;

        case 8:
            SubmitCmd(pECB, szBuffer);
            break;

        case 9:
            // menu
            MakeMainMenuForm(TermId, Term.pClientData[TermId].iSyncId,
                szBuffer);
            break;

        case 10:
            // CMD=Clear
            // resets all connections; should only be used when no
            other connections are active
            TermDeleteAll();
    }
}
```

## Appendix A - Application Source Code

```
        TermInit();
        WelcomeForm(pECB, szBuffer);
        break;
    case 11: // CMD=Stats
        StatsCmd(pECB, szBuffer);
        break;
    }
}
catch (CBaseErr *e)
{
    ErrorForm( pECB, e->ErrorType(), e->ErrorNum(), TermId, iSyncId, e-
>ErrorText(), szBuffer );
    delete e;
}
catch (...)
{
    ErrorForm( pECB, ERR_TYPE_WEBDLL, 0, TermId, iSyncId, "Error:
Unhandled exception in Web Client.", szBuffer );
}

#ifdef ICECAP
    StopCAP();
#endif

lpbSize = strlen(szBuffer);
wsprintf(szHeader1,
        "Content-Type: text/html\r\n"
        "Content-Length: %d\r\n"
        "Connection: Keep-Alive\r\n\r\n", lpbSize);
strcat( szHeader1, szBuffer );

(*pECB->ServerSupportFunction)(pECB->ConnID, HSE_REQ_SEND_RESPONSE_HEADER,
szHeader, (LPDWORD) &dwSize, (LPDWORD)szHeader1);

//finish up and keep connection
pECB->dwHttpStatusCode = 200;
return HSE_STATUS_SUCCESS_AND_KEEP_CONN;
}

void WriteMessageToEventLog(LPTSTR lpszMsg)
{
    TCHAR    szMsg[256];
    HANDLE   hEventSource;
    LPTSTR   lpszStrings[2];

    // Use event logging to log the error.
    //
    hEventSource = RegisterEventSource(NULL, TEXT("TPCC.DLL"));

    _stprintf(szMsg, TEXT("Error in TPCC.DLL: "));
    lpszStrings[0] = szMsg;
    lpszStrings[1] = lpszMsg;

    if (hEventSource != NULL)
    {
        ReportEvent(hEventSource, // handle of event source
            EVENTLOG_ERROR_TYPE, // event type
            0, // event category
            0, // event ID
            NULL, // current user's SID
            2, // strings in lpszStrings
```

```
0, // no bytes of raw data
(LPCTSTR *)lpszStrings, // array of error strings
NULL); // no raw data

    (VOID) DeregisterEventSource(hEventSource);
}

/* FUNCTION: DeliveryWorkerThread
 *
 * PURPOSE: This function processes deferred delivery txns. There are typically
several threads running this routine. The number of threads is
determined by an entry read from the registry. The thread waits for work by
waiting on semaphore. When a delivery txn is posted, the semaphore is released.
After processing the delivery txn, information is logged to record the txn
status and execution time.
 */

/*static*/ void DeliveryWorkerThread(void *ptr)
{
    CTPCC_BASE *pTxn = NULL;
    DELIVERY_TRANSACTION delivery;
    PDELIVERY_DATA pDeliveryData;
    TXN_RECORD_TPCC_DELIV_DEF txnDeliRec;
    DWORD index;
    HANDLE handles[2];
    SYSTEMTIME trans_end; //delivery
transaction finished time
    SYSTEMTIME trans_start; //delivery transaction start
time

    assert(txnDeliRec != NULL);

    try
    {
        if (Reg.eDB_Protocol == ODBC)
            pTxn = pCTPCC_ODBC_new( Reg.szDbServer, Reg.szDbUser,
Reg.szDbPassword, szMyComputerName, Reg.szDbName );
        else if (Reg.eDB_Protocol == DBLIB)
            pTxn = pCTPCC_DBLIB_new( Reg.szDbServer, Reg.szDbUser,
Reg.szDbPassword, szMyComputerName, Reg.szDbName );
        pDeliveryData = pTxn->BuffAddr_Delivery();
    }
    catch (CBaseErr *e)
    {
        char szTmp[1024];
        wsprintf( szTmp, "Error in Delivery Txn thread. Could not connect to
database. "
            "%s. Server=%s, User=%s, Password=%s",
            Database=%s",
            e->ErrorText(), Reg.szDbServer, Reg.szDbUser,
Reg.szDbPassword, Reg.szDbName );
        WriteMessageToEventLog( szTmp );
        delete e;
    }
}
```



## Appendix A - Application Source Code

```
    }
    else
        // No free buffers. Return an error, which indicates that the
        // delivery buffer is full.
        // Most likely, the number of delivery worker threads needs to be
        // increased to keep up
        // with the txn rate.
        bError = TRUE;
        LeaveCriticalSection(&DelBuffCriticalSection);

        if (!bError)
            // increment worker semaphore to wake up a worker thread
            ReleaseSemaphore( hWorkerSemaphore, 1, NULL );

        return bError;
    }

/* FUNCTION: ProcessQueryString
 *
 * PURPOSE:      This function extracts the relevent information out of the http
 *               command passed in from
 *               the browser.
 *
 * COMMENTS:     If this is the initial connection i.e. client is at welcome screen
 *               then
 *               there will not be a terminal id or current form
 *               id. If this is the case
 *               then the pTermid and pFormid return values are
 *               undefined.
 */

void ProcessQueryString(EXTENSION_CONTROL_BLOCK *pECB, int *pCmd, int *pFormId, int
*pTermId, int *pSyncId)
{
    char *ptr = pECB->lpszQueryString;
    char szBuffer[25];
    int i;

    //allowable client command strings i.e. CMD=command
    static char *szCmds[] =
    {
        "Process", "..NewOrder..", "..Payment..", "..Delivery..", "..Order-
        Status..", "..Stock-Level..",
        "..Exit..", "Submit", "Menu", "Clear", "Stats", ""
    };

    *pCmd = 0; // default is the login screen
    *pTermId = 0;

    // if no params (i.e., empty query string), then return login screen
    if (strlen(pECB->lpszQueryString) == 0)
        return;

    // parse FORMID, TERMID, and SYNCID
    *pFormId = GetIntKeyValue(&ptr, "FORMID", NO_ERR, NO_ERR);
    *pTermId = GetIntKeyValue(&ptr, "TERMID", NO_ERR, NO_ERR);
    *pSyncId = GetIntKeyValue(&ptr, "SYNCID", NO_ERR, NO_ERR);

    // parse CMD
    GetKeyValue(&ptr, "CMD", szBuffer, sizeof(szBuffer), ERR_COMMAND_UNDEFINED);

    // see which command it matches
    for(i=0; ; i++)
```

```
    {
        if (szCmds[i][0] == 0)
            // no more; no match; return error
            throw new CWEBCLNT_ERR( ERR_COMMAND_UNDEFINED );
        if ( !strcmp(szCmds[i], szBuffer) )
            {
                *pCmd = i+1;
                break;
            }
    }

/* FUNCTION: void WelcomeForm
 *
 */

void WelcomeForm(EXTENSION_CONTROL_BLOCK *pECB, char *szBuffer)
{
    char szTmp[1024];

    //welcome to tpc-c html form buffer, this is first form client sees.
    strcpy( szBuffer, "<HTML><HEAD><TITLE>TPC-C Web Client</TITLE></HEAD><BODY>"
        "<B><BIG>Microsoft TPC-C Web
Client (ver 4.20)</BIG></B> <BR> <BR>"
        "<font face=\\"Courier
New\\"><PRE>"
        "Compiled: \"__DATE__",
        "\"__TIME__" <BR>"
        "Source: \"__FILE__"
        "</PRE></font>"
        "<FORM ACTION=\\"tpcc.dll\\"
        METHOD=\\"GET\\">"
        "<INPUT TYPE=\\"hidden\\"
        NAME=\\"STATUSID\\" VALUE=\\"0\\">"
        "<INPUT TYPE=\\"hidden\\"
        NAME=\\"ERROR\\" VALUE=\\"0\\">"
        "<INPUT TYPE=\\"hidden\\"
        NAME=\\"FORMID\\" VALUE=\\"1\\">"
        "<INPUT TYPE=\\"hidden\\"
        NAME=\\"TERMID\\" VALUE=\\"0\\">"
        "<INPUT TYPE=\\"hidden\\"
        NAME=\\"SYNCID\\" VALUE=\\"0\\">"
        "<INPUT TYPE=\\"hidden\\"
        NAME=\\"VERSION\\" VALUE=\\" " WEBCLIENT_VERSION "\\">"
        );

    sprintf( szTmp, "Configuration Settings: <BR><font face=\\"Courier New\\"
        color=\\"blue\\"><PRE>"
        "Txn Monitor =
        <B>%s</B><BR>" "Database protocol =
        <B>%s</B><BR>" "Max Connections =
        <B>%d</B><BR>" "# of Delivery Threads =
        <B>%d</B><BR>" "Max Pending Deliveries =
        , szTxnMonNames[Reg.eTxnMon], szDBNames[Reg.eDB_Protocol],
        Reg.dwMaxConnections, dwNumDeliveryThreads, dwDelBuffSize
    );

    strcat( szBuffer, szTmp);
```



# Appendix A - Application Source Code

```

        Term.pClientData[iNewTerm].pTxn = pCTPCC_ODBC_new(
szServer, szUser, szPassword, szMyComputerName, szDatabase );
        else if (Reg.eDB_Protocol == DBLIB)
            Term.pClientData[iNewTerm].pTxn = pCTPCC_DBLIB_new(
szServer, szUser, szPassword, szMyComputerName, szDatabase );
    }
    catch (...)
    {
        TermDelete(iNewTerm);
        throw; // pass exception upward
    }

    MakeMainMenuForm(iNewTerm, Term.pClientData[iNewTerm].iSyncId, szBuffer);
}

/* FUNCTION: StatsCmd
 *
 * PURPOSE: This function returns to the browser the total number of active
terminal ids.
 *
 * This routine is for development/debugging purposes.
 *
 */

void StatsCmd(EXTENSION_CONTROL_BLOCK *pECB, char *szBuffer)
{
    int i;
    int iTotal;

    EnterCriticalSection(&TermCriticalSection);

    iTotal = 0;
    for(i=0; i<Term.iNumEntries; i++)
    {
        if (Term.pClientData[i].iNextFree == -1)
            iTotal++;
    }

    LeaveCriticalSection(&TermCriticalSection);

    wsprintf( szBuffer,
"<HTML><HEAD><TITLE>TPC-C Web Client Stats</TITLE></HEAD>"
"<BODY><B><BIG> Total Active Connections: %d"
, iTotal );
}

char *CWEBCLNT_ERR::ErrorText()
{
    static SERRORMSG errorMsgs[] =
    {
        { ERR_COMMAND_UNDEFINED,
"Command undefined." },
        { ERR_D_ID_INVALID,
"Invalid District ID Must be 1 to 10." },
        { ERR_DELIVERY_CARRIER_ID_RANGE,
"Delivery Carrier ID out of range must be 1 - 10." },
        { ERR_DELIVERY_CARRIER_INVALID,
"Delivery
Carrier ID invalid must be numeric 1 - 10." }
    }
}

```

```

    { ERR_DELIVERY_MISSING_OCD_KEY,
"Delivery
missing Carrier ID key \"OCD*\"." },
    { ERR_DELIVERY_THREAD_FAILED,
"Could not start delivery worker thread." },
    { ERR_GETPROCADDR_FAILED,
"Could not map proc in DLL. GetProcAddress error. DLL=" },
    { ERR_HTML_ILL_FORMED,
"Required key field is missing from HTML string." },
    { ERR_INVALID_SYNC_CONNECTION,
"Invalid
Terminal Sync ID." },
    { ERR_INVALID_TERMID,
"Invalid Terminal ID." },
    { ERR_LOADDLL_FAILED,
"Load of DLL failed. DLL=" },
    { ERR_MAX_CONNECTIONS_EXCEEDED,
"connections available. Max Connections is probably too low." },
    { ERR_MISSING_REGISTRY_ENTRIES,
"registry entries are missing. Rerun INSTALL to correct." },
    { ERR_NEWORDER_CUSTOMER_INVALID,
"New Order customer id invalid data type, range = 1 to 3000." },
    { ERR_NEWORDER_CUSTOMER_KEY,
"New Order missing Customer key \"CID*\"." },
    { ERR_NEWORDER_DISTRICT_INVALID,
"New Order District ID Invalid range 1 - 10." },
    { ERR_NEWORDER_FORM_MISSING_DID,
"New Order missing District key \"DID*\"." },
    { ERR_NEWORDER_ITEMID_INVALID,
"Order Item Id is wrong data type, must be numeric." },
    { ERR_NEWORDER_ITEMID_RANGE,
"New Order Item Id is out of range. Range = 1 to 999999." },
    { ERR_NEWORDER_ITEMID_WITHOUT_SUPPW,
"Order Item_Id field entered without a corresponding Supp_W." },
    { ERR_NEWORDER_MISSING_IID_KEY,
"Order missing Item Id key \"IID*\"." },
    { ERR_NEWORDER_MISSING_QTY_KEY,
"Order Missing Qty key \"Qty##*\"." },
    { ERR_NEWORDER_MISSING_SUPPW_KEY,
"New Order missing Supp_W key \"SP##*\"." },
    { ERR_NEWORDER_NOITEMS_ENTERED,
"Order No order lines entered." },
    { ERR_NEWORDER_QTY_INVALID,
"New Order Qty invalid must be numeric range 1 - 99." },
    { ERR_NEWORDER_QTY_RANGE,
"New Order Qty is out of range. Range = 1 to 99." }
}

```

## Appendix A - Application Source Code

```

        {
            ERR_NEWORDER_QTY_WITHOUT_SUPPW,
            "New Order Qty field entered without a corresponding Supp_W."
        },
        {
            ERR_NEWORDER_SUPPW_INVALID,
            "New Order Supp_W invalid data type must be numeric."
        },
        {
            ERR_NO_SERVER_SPECIFIED,
            "No Server name specified."
        },
        {
            ERR_ORDERSTATUS_CID_AND_CLT,
            "Order Status Only Customer ID or Last Name may be entered, not both."
        },
        {
            ERR_ORDERSTATUS_CID_INVALID,
            "Order Status Customer ID invalid, range must be numeric 1 - 3000."
        },
        {
            ERR_ORDERSTATUS_CLT_RANGE,
            "Order Status Customer last name longer than 16 characters."
        },
        {
            ERR_ORDERSTATUS_DID_INVALID,
            "Order Status District invalid, value must be numeric 1 - 10."
        },
        {
            ERR_ORDERSTATUS_MISSING_CID_CLT,
            "Order Status Either Customer ID or Last Name must be entered."
        },
        {
            ERR_ORDERSTATUS_MISSING_CID_KEY,
            "Order Status missing Customer key \"CID*\"."
        },
        {
            ERR_ORDERSTATUS_MISSING_CLT_KEY,
            "Order Status missing Customer Last Name key \"CLT*\"."
        },
        {
            ERR_ORDERSTATUS_MISSING_DID_KEY,
            "Order Status missing District key \"DID*\"."
        },
        {
            ERR_PAYMENT_CDI_INVALID,
            "Payment Customer district invalid must be numeric."
        },
        {
            ERR_PAYMENT_CID_AND_CLT,
            "Payment Only Customer ID or Last Name may be entered, not both."
        },
        {
            ERR_PAYMENT_CUSTOMER_INVALID,
            "Payment Customer data type invalid, must be numeric."
        },
        {
            ERR_PAYMENT_CWI_INVALID,
            "Payment Customer Warehouse invalid, must be numeric."
        },
        {
            ERR_PAYMENT_DISTRICT_INVALID,
            "Payment District ID is invalid, must be 1 - 10."
        },
        {
            ERR_PAYMENT_HAM_INVALID,
            "Payment Amount invalid data type must be numeric."
        },
        {
            ERR_PAYMENT_HAM_RANGE,
            "Payment Amount out of range, 0 - 9999.99."
        },
        {
            ERR_PAYMENT_LAST_NAME_TO_LONG,
            "Payment Customer last name longer than 16 characters."
        },
        {
            ERR_PAYMENT_MISSING_CDI_KEY,
            "Payment missing Customer district key \"CDI*\"."
        },
        {
            ERR_PAYMENT_MISSING_CID_CLT,
            "Payment Either Customer ID or Last Name must be entered."
        },
        {
            ERR_PAYMENT_MISSING_CID_KEY,
            "Payment missing Customer Key \"CID*\"."
        },
        {
            ERR_PAYMENT_MISSING_CLT_KEY,
            "Payment missing Customer Last Name key \"CLT*\"."
        },
        {
            ERR_PAYMENT_MISSING_CWI_KEY,
            "Payment missing Customer Warehouse key \"CWI*\"."
        },
        {
            ERR_PAYMENT_MISSING_DID_KEY,
            "Payment missing District Key \"DID*\"."
        },
        {
            ERR_PAYMENT_MISSING_HAM_KEY,
            "Payment missing Amount key \"HAM*\"."
        },
        {
            ERR_STOCKLEVEL_MISSING_THRESHOLD_KEY,
            "Stock Level; missing Threshold key \"TT*\"."
        },
        {
            ERR_STOCKLEVEL_THRESHOLD_INVALID,
            "Stock Level; Threshold value must be in the range = 1 - 99."
        },
        {
            ERR_STOCKLEVEL_THRESHOLD_RANGE,
            "Stock Level Threshold out of range, range must be 1 - 99."
        },
        {
            ERR_VERSION_MISMATCH,
            "Invalid version field. RTE and Web Client are probably out of sync."
        },
        {
            ERR_W_ID_INVALID,
            "Invalid Warehouse ID."
        },
        {
            0,
            ""
        }
    },
};

char szTmp[256];
int i = 0;
while (TRUE)
{
    if (errorMsgs[i].szMsg[0] == 0)
    {
        strcpy( szTmp, "Unknown error number." );
        break;
    }
    if (m_Error == errorMsgs[i].iError)
    {
        strcpy( szTmp, errorMsgs[i].szMsg );
        break;
    }
    i++;
}

if (m_szTextDetail)
    strcat( szTmp, m_szTextDetail );
if (m_SystemErr)
    wsprintf( szTmp+strlen(szTmp), " Error=%d", m_SystemErr );

m_szErrorText = new char[strlen(szTmp)+1];
strcpy( m_szErrorText, szTmp );
return m_szErrorText;
}

/* FUNCTION: GetKeyValue
 *
 * PURPOSE:      This function parses a http formatted string for specific key values.
 *
 * ARGUMENTS:   char          *pQueryString      http string from
                client browser

```

## Appendix A - Application Source Code

```
*          char          *pKey
* key value to look for          char          *pValue
* character array into which to place key's value
*          int          iMax
*          maximum length of key value array.
*          WEBERROR      err
* error value to throw
*
* RETURNS:          nothing.
*
* ERROR:          if (the pKey value is not found) then
*                  if (err == 0)
*                      return (empty string)
*                  else
*                      throw CWEBCLNT_ERR(err)
*
* COMMENTS:          http keys are formatted either KEY=value& or KEY=value\0. This DLL
* formats
*                  TPC-C input fields in such a manner that the keys
* can be extracted in the
*                  above manner.
*/

void GetKeyValue(char **pQueryString, char *pKey, char *pValue, int iMax, WEBERROR err)
{
    char *ptr;

    if ( !(ptr=strstr(*pQueryString, pKey)) )
        goto ErrorExit;
    ptr += strlen(pKey);
    if ( *ptr != '=' )
        goto ErrorExit;
    ptr++;

    iMax--; // one position is for terminating null
    while( *ptr && *ptr != '&' && iMax)
    {
        *pValue++ = *ptr++;
        iMax--;
    }
    *pValue = 0; // terminating null

    *pQueryString = ptr;
    return;

ErrorExit:
    if (err != NO_ERR)
        throw new CWEBCLNT_ERR( err );
    *pValue = 0; // return empty result string
}

/* FUNCTION: GetIntKeyValue
*
* PURPOSE:          This function parses a http formatted string for a specific key
* value.
*
* ARGUMENTS:          char          *pQueryString      http string from
* client browser
*
*          char          *pKey
*          key value to look for
*          WEBERROR      NoKeyErr      error
* value to throw if key not found
```

```
          WEBERROR      NotIntErr      error
* value to throw if value not numeric
*
* RETURNS:          integer
*
* ERROR:          if (the pKey value is not found) then
*                  if (NoKeyErr != NO_ERR)
*                      throw CWEBCLNT_ERR(err)
*                  else
*                      return 0
*                  else if (non-numeric char found) then
*                      if (NotIntErr != NO_ERR) then
*                          throw CWEBCLNT_ERR(err)
*                      else
*                          return 0
*
* COMMENTS:          http keys are formatted either KEY=value& or KEY=value\0. This DLL
* formats
*                  TPC-C input fields in such a manner that the keys
* can be extracted in the
*                  above manner.
*/

int GetIntKeyValue(char **pQueryString, char *pKey, WEBERROR NoKeyErr, WEBERROR
NotIntErr)
{
    char *ptr0;
    char *ptr;

    if ( !(ptr=strstr(*pQueryString, pKey)) )
        goto ErrorNoKey;
    ptr += strlen(pKey);
    if ( *ptr != '=' )
        goto ErrorNoKey;
    ptr++;

    ptr0 = ptr; // remember starting point
    // scan string until a terminator (null or &) or a non-digit
    while( *ptr && *ptr != '&' && isdigit(*ptr) )
        ptr++;

    // make sure we stopped scanning for the right reason
    if ((ptr0 == ptr) || (*ptr && *ptr != '&'))
    {
        if (NotIntErr != NO_ERR)
            throw new CWEBCLNT_ERR( NoKeyErr );
        return 0;
    }

    *pQueryString = ptr;
    return atoi(ptr0);

ErrorNoKey:
    if (NoKeyErr != NO_ERR)
        throw new CWEBCLNT_ERR( NoKeyErr );
    return 0;
}

/* FUNCTION: TermInit
*
* PURPOSE:          This function initializes the client terminal structure; it is called
* when the TPCC.DLL
*                  is first loaded by the inet service.
```

## Appendix A - Application Source Code

```
*
*/
void TermInit(void)
{
    EnterCriticalSection(&TermCriticalSection);

    Term.iMasterSyncId = 1;
    Term.iNumEntries = Reg.dwMaxConnections+1;

    Term.pClientData = NULL;
    Term.pClientData = (PCLIENTDATA)malloc(Term.iNumEntries *
sizeof(CLIENTDATA));
    if (Term.pClientData == NULL)
    {
        LeaveCriticalSection(&TermCriticalSection);
        throw new CWEBCLNT_ERR( ERR_MEM_ALLOC_FAILED );
    }

    ZeroMemory( Term.pClientData, Term.iNumEntries * sizeof(CLIENTDATA) );

    Term.iFreeList = Term.iNumEntries-1;
    // build free list
    // note: Term.pClientData[0].iNextFree gets set to -1, which marks it as "in
use".
    // This is intentional, as the zero entry is used as an anchor and never
    // allocated as an actual terminal.
    for(int i=0; i<Term.iNumEntries; i++)
        Term.pClientData[i].iNextFree = i-1;

    LeaveCriticalSection(&TermCriticalSection);
}

/* FUNCTION: TermDeleteAll
*
* PURPOSE: This function frees allocated resources associated with the terminal
structure.
*
* ARGUMENTS: none
*
* RETURNS: None
*
* COMMENTS: This function is called only when the inet service unloads the
TPCC.DLL
*
*/
void TermDeleteAll(void)
{
    EnterCriticalSection(&TermCriticalSection);

    for(int i=1; i<Term.iNumEntries; i++)
    {
        if (Term.pClientData[i].iNextFree == -1)
            delete Term.pClientData[i].pTxn;
    }

    Term.iFreeList = 0;
    Term.iNumEntries = 0;
    if ( Term.pClientData )
        free(Term.pClientData);
    Term.pClientData = NULL;
}
```

```
        LeaveCriticalSection(&TermCriticalSection);
    }

/* FUNCTION: TermAdd
*
* PURPOSE: This function assigns a terminal id which is used to identify a
client browser.
*
* RETURNS: int assigned terminal id
*
*/
int TermAdd(void)
{
    DWORD i;
    int iNewTerm, iTickCount;

    if (Term.iNumEntries == 0)
        return -1;

    EnterCriticalSection(&TermCriticalSection);
    if (Term.iFreeList != 0)
    {
        // position is available
        iNewTerm = Term.iFreeList;
        Term.iFreeList = Term.pClientData[iNewTerm].iNextFree;
        Term.pClientData[iNewTerm].iNextFree = -1; // indicates this
position is in use
    }
    else
    {
        // no open slots, so find the slot that hasn't been used in the
longest time and reuse it
        for(iNewTerm=1, i=1, iTickCount=0x7FFFFFFF; i<Reg.dwMaxConnections;
i++)
        {
            if ( iTickCount > Term.pClientData[i].iTickCount)
            {
                iTickCount = Term.pClientData[i].iTickCount;
                iNewTerm = i;
            }
        }
        // if oldest term is less than one minute old, it probably means that
more connections
// are being attempted than were specified as "Max Connections" at
install. In this case,
// do not bump existing connection; instead, return error to
requestor.
        if ((GetTickCount() - iTickCount) < 60000)
        {
            LeaveCriticalSection(&TermCriticalSection);
            throw new CWEBCLNT_ERR( ERR_MAX_CONNECTIONS_EXCEEDED );
        }
    }

    Term.pClientData[iNewTerm].iTickCount = GetTickCount();
    Term.pClientData[iNewTerm].iSyncId = Term.iMasterSyncId++;
    Term.pClientData[iNewTerm].pTxn = NULL;

    LeaveCriticalSection(&TermCriticalSection);
    return iNewTerm;
}

/* FUNCTION: TermDelete
*
*/
```

# Appendix A - Application Source Code

```
* PURPOSE:          This function makes a terminal entry in the Term array available for
reuse.
*
* ARGUMENTS:       int          id
                  Terminal id of client exiting
*
*/

void TermDelete(int id)
{
    if ( id > 0 && id < Term.iNumEntries )
    {
        delete Term.pClientData[id].pTxn;

        // put onto free list
        EnterCriticalSection(&TermCriticalSection);

        Term.pClientData[id].iNextFree = Term.iFreeList;
        Term.iFreeList = id;

        LeaveCriticalSection(&TermCriticalSection);
    }
}

/* FUNCTION: MakeErrorForm
*/

void ErrorForm(EXTENSION_CONTROL_BLOCK *pECB, int iType, int iErrorNum, int iTermId, int
iSyncId, char *szErrorText, char *szBuffer )
{
    wsprintf(szBuffer,
"<HTML><HEAD><TITLE>TPC-C Error</TITLE></HEAD><BODY>"
"<FORM ACTION=\"tpcc.dll\" METHOD=\"GET\">"
"<INPUT TYPE=\"hidden\" NAME=\"STATUSID\" VALUE=\"%d\">"
"<INPUT TYPE=\"hidden\" NAME=\"ERROR\" VALUE=\"%d\">"
"<INPUT TYPE=\"hidden\" NAME=\"FORMID\" VALUE=\"%d\">"
"<INPUT TYPE=\"hidden\" NAME=\"TERMINID\" VALUE=\"%d\">"
"<INPUT TYPE=\"hidden\" NAME=\"SYNCID\" VALUE=\"%d\">"
"<BOLD>An Error Occurred</BOLD><BR><BR>"
"%s"
"<BR><BR><HR>"
"<INPUT TYPE=\"submit\" NAME=\"CMD\" VALUE=\"..NewOrder..\">"
"<INPUT TYPE=\"submit\" NAME=\"CMD\" VALUE=\"..Payment..\">"
"<INPUT TYPE=\"submit\" NAME=\"CMD\" VALUE=\"..Delivery..\">"
"<INPUT TYPE=\"submit\" NAME=\"CMD\" VALUE=\"..Order-Status..\">"
"<INPUT TYPE=\"submit\" NAME=\"CMD\" VALUE=\"..Stock-Level..\">"
"<INPUT TYPE=\"submit\" NAME=\"CMD\" VALUE=\"..Exit..\">"
"</FORM></BODY></HTML>"
, iType, iErrorNum, MAIN_MENU_FORM, iTermId, iSyncId, szErrorText );
}

/* FUNCTION: MakeMainMenuForm
*/

void MakeMainMenuForm(int iTermId, int iSyncId, char *szForm)
{
    wsprintf(szForm,
"<HTML><HEAD><TITLE>TPC-C Main Menu</TITLE></HEAD><BODY>"
"Select Desired Transaction.<BR><HR>"
"<FORM ACTION=\"tpcc.dll\" METHOD=\"GET\">"
"<INPUT TYPE=\"hidden\" NAME=\"STATUSID\" VALUE=\"0\">"
"<INPUT TYPE=\"hidden\" NAME=\"ERROR\" VALUE=\"0\">"

```

```
"<INPUT TYPE=\"hidden\" NAME=\"FORMID\" VALUE=\"%d\">"
"<INPUT TYPE=\"hidden\" NAME=\"TERMINID\" VALUE=\"%d\">"
"<INPUT TYPE=\"hidden\" NAME=\"SYNCID\" VALUE=\"%d\">"
"<INPUT TYPE=\"submit\" NAME=\"CMD\" VALUE=\"..NewOrder..\">"
"<INPUT TYPE=\"submit\" NAME=\"CMD\" VALUE=\"..Payment..\">"
"<INPUT TYPE=\"submit\" NAME=\"CMD\" VALUE=\"..Delivery..\">"
"<INPUT TYPE=\"submit\" NAME=\"CMD\" VALUE=\"..Order-Status..\">"
"<INPUT TYPE=\"submit\" NAME=\"CMD\" VALUE=\"..Stock-Level..\">"
"<INPUT TYPE=\"submit\" NAME=\"CMD\" VALUE=\"..Exit..\">"
"</FORM></BODY></HTML>"
, MAIN_MENU_FORM, iTermId, iSyncId);
}

/* FUNCTION: MakeStockLevelForm
*
* PURPOSE:          This function constructs the Stock Level HTML page.
*
* COMMENTS:        The internal client buffer is created when the terminal id is
assigned and should not
                    be freed except when the client terminal id is no
longer needed.
*/

void MakeStockLevelForm(int iTermId, STOCK_LEVEL_DATA *pStockLevelData, BOOL bInput, char
*szForm)
{
    int c;

    c = wsprintf(szForm,
"<HTML><HEAD><TITLE>TPC-C Stock Level</TITLE></HEAD><FORM
ACTION=\"tpcc.dll\" METHOD=\"GET\">"
"<INPUT TYPE=\"hidden\" NAME=\"STATUSID\" VALUE=\"0\">"
"<INPUT TYPE=\"hidden\" NAME=\"ERROR\" VALUE=\"0\">"
"<INPUT TYPE=\"hidden\" NAME=\"FORMID\" VALUE=\"%d\">"
"<INPUT TYPE=\"hidden\" NAME=\"TERMINID\" VALUE=\"%d\">"
"<INPUT TYPE=\"hidden\" NAME=\"SYNCID\" VALUE=\"%d\">"
"<PRE><font face=\"Courier\">
Stock-
Level<BR>"
"Warehouse: %4.4d District: %2.2d<BR> <BR>",
STOCK_LEVEL_FORM, iTermId, Term.pClientData[iTermId].iSyncId,
Term.pClientData[iTermId].w_id, Term.pClientData[iTermId].d_id);

    if ( bInput )
    {
        strcpy(szForm+c,
"Stock Level Threshold: <INPUT NAME=\"TT\" SIZE=2><BR>"
"low stock: </font><BR> <BR> <BR> <BR> <BR> <BR> <BR>"
" <BR> <BR> <BR> <BR> <BR> <BR> <BR></PRE><HR>"
"<INPUT TYPE=\"submit\" NAME=\"CMD\" VALUE=\"Process\">"
"<INPUT TYPE=\"submit\" NAME=\"CMD\" VALUE=\"Menu\">"
"</FORM></HTML>" );
    }
    else
    {
        wsprintf(szForm+c,
"Stock Level Threshold: %2.2d<BR> <BR>"
"low stock: %3.3d</font> <BR> <BR> <BR> <BR> <BR> <BR> <BR>"
" <BR> <BR> <BR> <BR> <BR> <BR> <BR></PRE><HR>"
"<INPUT TYPE=\"submit\" NAME=\"CMD\" VALUE=\"..NewOrder..\">"

```



# Appendix A - Application Source Code

```

        {
            c += sprintf(szForm+c,
                "%%Disc: %5.2f
<BR>"
                "Order Number: %8.8d Number
of Lines: %2.2d      W_tax: %5.2f  D_tax: %5.2f <BR> <BR>"
                " Supp_W Item_Id Item Name
Qty Stock B/G Price  Amount<BR>",
                100.0*pNewOrderData->c_discount,
                pNewOrderData->o_id,
                pNewOrderData->o_ol_cnt,
                100.0 * pNewOrderData->w_tax,
                100.0 * pNewOrderData->d_tax);

            for(i=0; i<pNewOrderData->o_ol_cnt; i++)
            {
                c += sprintf(szForm+c, " %4.4d %6.6d %-24s
%2.2d %3.3d %1.1s  $%6.2f  $%7.2f <BR>",
                pNewOrderData->OL[i].ol_supply_w_id,
                pNewOrderData->OL[i].ol_i_id,
                pNewOrderData->OL[i].ol_i_name,
                pNewOrderData->OL[i].ol_quantity,
                pNewOrderData->OL[i].ol_stock,
                pNewOrderData->OL[i].ol_brand_generic,
                pNewOrderData->OL[i].ol_i_price,
                pNewOrderData->OL[i].ol_amount );
            }
        }
        else
        {
            c += wsprintf(szForm+c,
                "%Disc:<BR>"
                "Order Number: %8.8d Number of Lines:
                " Supp_W Item_Id Item Name      Qty
                , pNewOrderData->o_id);

            i = 0;

            strcpy( szForm+c, szBR, (15-i)*5 );
            c += (15-i)*5;

            if ( bValid )
                c += sprintf(szForm+c, "Execution Status: Transaction
                Total:  $%8.2f ",
                pNewOrderData->total_amount);
            else
                c += wsprintf(szForm+c, "Execution Status: Item number is
                Total:");

            strcpy(szForm+c,
                " <BR></font></PRE><HR>"
                "<INPUT TYPE=\\"submit\\" NAME=\\"CMD\\"
                VALUE=\\"..NewOrder..\\">"
                "<INPUT TYPE=\\"submit\\" NAME=\\"CMD\\"
                VALUE=\\"..Payment..\\">"
                "<INPUT TYPE=\\"submit\\" NAME=\\"CMD\\"
                VALUE=\\"..Delivery..\\">"
                "<INPUT TYPE=\\"submit\\" NAME=\\"CMD\\" VALUE=\\"..Order-
                Status..\\">"

```

```

                "<INPUT TYPE=\\"submit\\" NAME=\\"CMD\\" VALUE=\\"..Stock-
                Level..\\">"
                "<INPUT TYPE=\\"submit\\" NAME=\\"CMD\\" VALUE=\\"..Exit..\\">"
                "</FORM></HTML>"
            );
        }
    }

    /* FUNCTION: MakePaymentForm
    *
    * COMMENTS:      The internal client buffer is created when the terminal id is
    *                  assigned and should not
    *                  be freed except when the client terminal id is no
    *                  longer needed.
    */

    void MakePaymentForm(int iTermId, PAYMENT_DATA *pPaymentData, BOOL bInput, char *szForm)
    {
        int c;

        c = wsprintf(szForm,
            "<HTML><HEAD><TITLE>TPC-C Payment</TITLE></HEAD><BODY>"
            "<FORM ACTION=\\"tpcc.dll\\" METHOD=\\"GET\\">"
            "<INPUT TYPE=\\"hidden\\" NAME=\\"STATUSID\\" VALUE=\\"0\\">"
            "<INPUT TYPE=\\"hidden\\" NAME=\\"ERROR\\" VALUE=\\"0\\">"
            "<INPUT TYPE=\\"hidden\\" NAME=\\"FORMID\\" VALUE=\\"%d\\">"
            "<INPUT TYPE=\\"hidden\\" NAME=\\"TERMINID\\" VALUE=\\"%d\\">"
            "<INPUT TYPE=\\"hidden\\" NAME=\\"SYNCID\\" VALUE=\\"%d\\">"
            "<PRE><font face=\\"Courier\\">

        Payment<BR>"
            "Date: "
            , PAYMENT_FORM, iTermId, Term.pClientData[iTermId].iSyncId);

        if ( !bInput )
        {
            c += wsprintf(szForm+c, "%2.2d-%2.2d-%4.4d %2.2d:%2.2d:%2.2d",
                pPaymentData->h_date.day,
                pPaymentData->h_date.month,
                pPaymentData->h_date.year,
                pPaymentData->h_date.hour,
                pPaymentData->h_date.minute,
                pPaymentData->h_date.second);
        }

        if ( bInput )
        {
            c += wsprintf(szForm+c,
                "<BR> <BR>Warehouse: %4.4d"
                " District: <INPUT NAME=\\"DID*\\"
                SIZE=1><BR> <BR> <BR> <BR> <BR>"
                "Customer: <INPUT NAME=\\"CID*\\" SIZE=4>"
                "Cust-Warehouse: <INPUT NAME=\\"CWI*\\" SIZE=4> "
                "Cust-District: <INPUT NAME=\\"CDI*\\" SIZE=1><BR>"
                "Name: <INPUT NAME=\\"CLT*\\" SIZE=16>

        Since:<BR>"
            "
        Credit:<BR>"
            "
        Disc:<BR>"
            "
        Phone:<BR> <BR>"
            "Amount Paid: $<INPUT NAME=\\"HAM*\\" SIZE=7>

        New Cust-Balance:<BR>"

```



# Appendix A - Application Source Code

```

    " <BR> <BR> <BR> <BR> <BR> <BR> <BR> <BR> <BR> <BR>
<BR></font></PRE>"
    "<HR><INPUT TYPE=\"submit\" NAME=\"CMD\"
VALUE=\"Process\"><INPUT TYPE=\"submit\" NAME=\"CMD\" VALUE=\"Menu\">"
    "</BODY></FORM></HTML>" );
}
else
{
    c += sprintf(szForm+c,
        "District: %2.2d<BR>"
        "Customer: %4.4d Name: %-16s %-2s %-16s<BR>",
        pOrderStatusData->d_id, pOrderStatusData->c_id,
        pOrderStatusData->c_first, pOrderStatusData->c_middle,
pOrderStatusData->c_last);

    c += sprintf(szForm+c, "Cust-Balance: $%9.2f<BR> <BR>",
        pOrderStatusData->c_balance);

    c += sprintf(szForm+c,
        "Order-Number: %8.8d Entry-Date: %2.2d-%2.2d-%4.4d
%2.2d:%2.2d:%2.2d Carrier-Number: %2.2d<BR>"
        "Supply-W Item-Id Qty Amount Delivery-
Date<BR>",
        pOrderStatusData->o_id,
        pOrderStatusData->o_entry_d.day,
        pOrderStatusData->o_entry_d.month,
        pOrderStatusData->o_entry_d.year,
        pOrderStatusData->o_entry_d.hour,
        pOrderStatusData->o_entry_d.minute,
        pOrderStatusData->o_entry_d.second,
        pOrderStatusData->o_carrier_id);

    for(i=0; i< pOrderStatusData->o_ol_cnt; i++)
    {
        c += sprintf(szForm+c, " %4.4d %6.6d %2.2d
%8.2f %2.2d-%2.2d-%4.4d<BR>",
            pOrderStatusData->OL[i].ol_supply_w_id,
            pOrderStatusData->OL[i].ol_i_id,
            pOrderStatusData->OL[i].ol_quantity,
            pOrderStatusData->OL[i].ol_amount,
            pOrderStatusData->OL[i].ol_delivery_d.day,
            pOrderStatusData->OL[i].ol_delivery_d.month,
            pOrderStatusData->OL[i].ol_delivery_d.year);
    }

    strncpy( szForm+c, szBR, (15-i)*5 );
    c += (15-i)*5;

    strcpy(szForm+c,
        "</font></PRE><HR><INPUT TYPE=\"submit\" NAME=\"CMD\"
VALUE=\"..NewOrder..\">"
        "<INPUT TYPE=\"submit\" NAME=\"CMD\"
VALUE=\"..Payment..\">"
        "<INPUT TYPE=\"submit\" NAME=\"CMD\"
VALUE=\"..Delivery..\">"
        "<INPUT TYPE=\"submit\" NAME=\"CMD\" VALUE=\"..Order-
Status..\">"
        "<INPUT TYPE=\"submit\" NAME=\"CMD\" VALUE=\"..Stock-
Level..\">"
        "<INPUT TYPE=\"submit\" NAME=\"CMD\" VALUE=\"..Exit..\">"
        "</BODY></FORM></HTML>" );
}
}

```

```

/* FUNCTION: MakeDeliveryForm
*
* COMMENTS: The internal client buffer is created when the terminal id is
assigned and should not
*
* be freed except when the client terminal id is no
longer needed.
*/

void MakeDeliveryForm(int iTermId, DELIVERY_DATA *pDeliveryData, BOOL bInput, char
*szForm)
{
    int c;

    c = sprintf(szForm,
        "<HTML><HEAD><TITLE>TPC-C Delivery</TITLE></HEAD><BODY>"
        "<FORM ACTION=\"tpcc.dll\" METHOD=\"GET\">"
        "<INPUT TYPE=\"hidden\" NAME=\"STATUSID\" VALUE=\"%d\">"
        "<INPUT TYPE=\"hidden\" NAME=\"ERROR\" VALUE=\"0\">"
        "<INPUT TYPE=\"hidden\" NAME=\"FORMID\" VALUE=\"%d\">"
        "<INPUT TYPE=\"hidden\" NAME=\"TERMINID\" VALUE=\"%d\">"
        "<INPUT TYPE=\"hidden\" NAME=\"SYCID\" VALUE=\"%d\">"
        "<PRE><font face=\"Courier\">"
Delivery<BR>"
        "Warehouse: %4.4d<BR> <BR>",
        (bInput && (pDeliveryData->exec_status_code != eOK)) ?
ERR_TYPE_DELIVERY_POST : 0,
        DELIVERY_FORM, iTermId, Term.pClientData[iTermId].iSyncId,
Term.pClientData[iTermId].w_id);

    if ( bInput )
    {
        strcpy( szForm+c,
            "Carrier Number: <INPUT NAME=\"OCD*\" SIZE=1><BR> <BR>"
            "Execution Status: <BR> <BR> <BR> <BR> <BR> <BR> <BR> <BR>"
            " <BR> <BR> <BR> <BR> <BR> <BR> <BR> <BR> <BR>"
</font></PRE><HR>"
            "<INPUT TYPE=\"submit\" NAME=\"CMD\" VALUE=\"Process\">"
            "<INPUT TYPE=\"submit\" NAME=\"CMD\" VALUE=\"Menu\">"
            "</BODY></FORM></HTML>" );
    }
    else
    {
        sprintf( szForm+c,
            "Carrier Number: %2.2d<BR> <BR>"
            "Execution Status: %s <BR> <BR> <BR> <BR> <BR> <BR> <BR> <BR>"
<BR>"
            " <BR> <BR> <BR> <BR> <BR> <BR> <BR> <BR> <BR> </font></PRE>"
            "<HR><INPUT TYPE=\"submit\" NAME=\"CMD\"
VALUE=\"..NewOrder..\">"
            "<INPUT TYPE=\"submit\" NAME=\"CMD\"
VALUE=\"..Payment..\">"
            "<INPUT TYPE=\"submit\" NAME=\"CMD\"
VALUE=\"..Delivery..\">"
            "<INPUT TYPE=\"submit\" NAME=\"CMD\" VALUE=\"..Order-
Status..\">"
            "<INPUT TYPE=\"submit\" NAME=\"CMD\" VALUE=\"..Stock-
Level..\">"
            "<INPUT TYPE=\"submit\" NAME=\"CMD\" VALUE=\"..Exit..\">"
            "</BODY></FORM></HTML>"
        , pDeliveryData->o_carrier_id,
    }
}

```

## Appendix A - Application Source Code

```
        (pDeliveryData->exec_status_code == eOK) ? "Delivery has
been queued." : "Delivery Post Failed "
    );
}

/* FUNCTION: ProcessNewOrderForm
 *
 * PURPOSE:      This function gets and validates the input data from the new order
form
 *              filling in the required input variables. it then calls the
SQLNewOrder
 *              transaction, constructs the output form and writes it back
to client
 *              browser.
 */

void ProcessNewOrderForm(EXTENSION_CONTROL_BLOCK *pECB, int iTermId, char *szBuffer)
{
    PNEW_ORDER_DATA      pNewOrder;

    pNewOrder = Term.pClientData[iTermId].pTxn->BuffAddr_NewOrder();

    ZeroMemory(pNewOrder, sizeof(NEW_ORDER_DATA));
    pNewOrder->w_id = Term.pClientData[iTermId].w_id;
    GetNewOrderData(pECB->lpszQueryString, pNewOrder);

    Term.pClientData[iTermId].pTxn->NewOrder();

    pNewOrder = Term.pClientData[iTermId].pTxn->BuffAddr_NewOrder();
    MakeNewOrderForm(iTermId, pNewOrder, OUTPUT_FORM, szBuffer );
}

/* FUNCTION: void ProcessPaymentForm
 *
 * PURPOSE:      This function gets and validates the input data from the payment form
 *              filling in the required input variables. It then calls the
SQLPayment
 *              transaction, constructs the output form and writes it back
to client
 *              browser.
 *
 * ARGUMENTS:   EXTENSION_CONTROL_BLOCK      *pECB      passed in structure pointer
from inetsrv.
 *              int
 *              iTermId      client browser terminal id
 */

void ProcessPaymentForm(EXTENSION_CONTROL_BLOCK *pECB, int iTermId, char *szBuffer)
{
    PPAYMENT_DATA      pPayment;

    pPayment = Term.pClientData[iTermId].pTxn->BuffAddr_Payment();
    ZeroMemory(pPayment, sizeof(PAYMENT_DATA));
    pPayment->w_id = Term.pClientData[iTermId].w_id;
    GetPaymentData(pECB->lpszQueryString, pPayment);

    Term.pClientData[iTermId].pTxn->Payment();

    pPayment = Term.pClientData[iTermId].pTxn->BuffAddr_Payment();
    MakePaymentForm(iTermId, pPayment, OUTPUT_FORM, szBuffer);
}
```

```
/* FUNCTION: ProcessOrderStatusForm
 *
 * PURPOSE:      This function gets and validates the input data from the Order Status
 *              form filling in the required input variables. It then calls
the
 *              SQLOrderStatus transaction, constructs the output form and
writes it
 *              back to client browser.
 *
 * ARGUMENTS:   EXTENSION_CONTROL_BLOCK      *pECB      passed in structure pointer
from inetsrv.
 *              int
 *              iTermId      client browser terminal id
 */

void ProcessOrderStatusForm(EXTENSION_CONTROL_BLOCK *pECB, int iTermId, char *szBuffer)
{
    PORDER_STATUS_DATA pOrderStatus;

    pOrderStatus = Term.pClientData[iTermId].pTxn->BuffAddr_OrderStatus();
    ZeroMemory(pOrderStatus, sizeof(ORDER_STATUS_DATA));
    pOrderStatus->w_id = Term.pClientData[iTermId].w_id;
    GetOrderStatusData(pECB->lpszQueryString, pOrderStatus);

    Term.pClientData[iTermId].pTxn->OrderStatus();

    pOrderStatus = Term.pClientData[iTermId].pTxn->BuffAddr_OrderStatus();
    MakeOrderStatusForm(iTermId, pOrderStatus, OUTPUT_FORM, szBuffer);
}

/* FUNCTION: ProcessDeliveryForm
 *
 * PURPOSE:      This function gets and validates the input data from the delivery
form
 *              filling in the required input variables. It then calls the
PostDeliveryInfo
 *              Api, The client is then informed that the transaction has
been posted.
 *
 * ARGUMENTS:   EXTENSION_CONTROL_BLOCK      *pECB      passed in structure pointer
from inetsrv.
 *              int
 *              iTermId      client browser terminal id
 */

void ProcessDeliveryForm(EXTENSION_CONTROL_BLOCK *pECB, int iTermId, char *szBuffer)
{
    char      *ptr = pECB->lpszQueryString;

    PDELIVERY_DATA      pDelivery;

    pDelivery = Term.pClientData[iTermId].pTxn->BuffAddr_Delivery();
    ZeroMemory(pDelivery, sizeof(DELIVERY_DATA));
    pDelivery->w_id = Term.pClientData[iTermId].w_id;

    pDelivery->o_carrier_id      = GetIntKeyValue(&ptr, "OCD*",
ERR_DELIVERY_MISSING_OCD_KEY, ERR_DELIVERY_CARRIER_INVALID);
    if ( pDelivery->o_carrier_id > 10 || pDelivery->o_carrier_id < 1 )
        throw new CWEBCLNT_ERR( ERR_DELIVERY_CARRIER_ID_RANGE );
}
```

# Appendix A - Application Source Code

```
if (dwNumDeliveryThreads)
{
    //post delivery info
    if ( PostDeliveryInfo(pDelivery->w_id, pDelivery->o_carrier_id )
        pDelivery->exec_status_code = eDeliveryFailed;
    else
        pDelivery->exec_status_code = eOK;
}
else // delivery is done synchronously if no delivery threads configured
    Term.pClientData[iTermId].pTxn->Delivery();

pDelivery = Term.pClientData[iTermId].pTxn->BuffAddr_Delivery();
MakeDeliveryForm(iTermId, pDelivery, OUTPUT_FORM, szBuffer);
}

/* FUNCTION: ProcessStockLevelForm
 *
 * PURPOSE:      This function gets and validates the input data from the Stock Level
 *               form filling in the required input variables. It then calls
 *               the SQLStockLevel transaction, constructs the output form and
 *               writes it back to client browser.
 *
 * ARGUMENTS:    EXTENSION_CONTROL_BLOCK *pECB    passed in structure pointer
 *               from inetsrv.
 *               int iTermId    client browser terminal id
 */

void ProcessStockLevelForm(EXTENSION_CONTROL_BLOCK *pECB, int iTermId, char *szBuffer)
{
    char *ptr = pECB->lpszQueryString;

    PSTOCK_LEVEL_DATA pStockLevel;

    pStockLevel = Term.pClientData[iTermId].pTxn->BuffAddr_StockLevel();
    ZeroMemory( pStockLevel, sizeof(STOCK_LEVEL_DATA) );

    pStockLevel->w_id = Term.pClientData[iTermId].w_id;
    pStockLevel->d_id = Term.pClientData[iTermId].d_id;

    pStockLevel->threshold = GetIntKeyValue(&ptr, "TT*",
ERR_STOCKLEVEL_MISSING_THRESHOLD_KEY, ERR_STOCKLEVEL_THRESHOLD_INVALID);
    if ( pStockLevel->threshold >= 100 || pStockLevel->threshold < 0 )
        throw new CWEBCLNT_ERR( ERR_STOCKLEVEL_THRESHOLD_RANGE );

    Term.pClientData[iTermId].pTxn->StockLevel();

    pStockLevel = Term.pClientData[iTermId].pTxn->BuffAddr_StockLevel();
    MakeStockLevelForm(iTermId, pStockLevel, OUTPUT_FORM, szBuffer);
}

/* FUNCTION: GetNewOrderData
 *
 * PURPOSE:      This function extracts and validates the new order form data from an
 *               http command string.
 *
 * ARGUMENTS:    LPSTR lpszQueryString    client
 *               browser http command string
 *               NEW_ORDER_DATA *pNewOrderData
 *               pointer to new order data structure
 */
```

```
*
*/

void GetNewOrderData(LPSTR lpszQueryString, NEW_ORDER_DATA *pNewOrderData)
{
    char szTmp[26];
    int i;
    short items;
    int ol_i_id, ol_quantity;
    char *ptr = lpszQueryString;

    static char szSP[MAX_OL_NEW_ORDER_ITEMS][6] =
    { "SP00*", "SP01*", "SP02*", "SP03*", "SP04*",
      "SP05*", "SP06*", "SP07*", "SP08*", "SP09*",
      "SP10*", "SP11*", "SP12*", "SP13*", "SP14*" };
    static char szIID[MAX_OL_NEW_ORDER_ITEMS][7] =
    { "IID00*", "IID01*", "IID02*", "IID03*", "IID04*",
      "IID05*", "IID06*", "IID07*", "IID08*", "IID09*",
      "IID10*", "IID11*", "IID12*", "IID13*", "IID14*" };
    static char szQty[MAX_OL_NEW_ORDER_ITEMS][7] =
    { "Qty00*", "Qty01*", "Qty02*", "Qty03*", "Qty04*",
      "Qty05*", "Qty06*", "Qty07*", "Qty08*", "Qty09*",
      "Qty10*", "Qty11*", "Qty12*", "Qty13*", "Qty14*" };

    pNewOrderData->d_id = GetIntKeyValue(&ptr, "DID*",
ERR_NEWORDER_FORM_MISSING_DID, ERR_NEWORDER_DISTRICT_INVALID);
    pNewOrderData->c_id = GetIntKeyValue(&ptr, "CID*", ERR_NEWORDER_CUSTOMER_KEY,
ERR_NEWORDER_CUSTOMER_INVALID);

    for(i=0, items=0; i<MAX_OL_NEW_ORDER_ITEMS; i++)
    {
        GetKeyValue(&ptr, szSP[i], szTmp, sizeof(szTmp),
ERR_NEWORDER_MISSING_SUPPW_KEY);
        if ( szTmp[0] )
        {
            if ( !IsNumeric(szTmp) )
                throw new CWEBCLNT_ERR(
ERR_NEWORDER_SUPPW_INVALID );
            pNewOrderData->OL[items].ol_supply_w_id =
(short)atoi(szTmp);

            ol_i_id = pNewOrderData->OL[items].ol_i_id =
GetIntKeyValue(&ptr, szIID[i],
ERR_NEWORDER_MISSING_IID_KEY, ERR_NEWORDER_ITEMID_INVALID);
            if ( ol_i_id > 999999 || ol_i_id < 1 )
                throw new CWEBCLNT_ERR( ERR_NEWORDER_ITEMID_RANGE );

            ol_quantity = pNewOrderData->OL[items].ol_quantity =
GetIntKeyValue(&ptr, szQty[i],
ERR_NEWORDER_MISSING_QTY_KEY, ERR_NEWORDER_QTY_INVALID);
            if ( ol_quantity > 99 || ol_quantity < 1 )
                throw new CWEBCLNT_ERR( ERR_NEWORDER_QTY_RANGE );

            items++;
        }
        else
        {
            // nothing entered for supply warehouse, so item id and qty
            must also be blank
            GetKeyValue(&ptr, szIID[i], szTmp, sizeof(szTmp),
ERR_NEWORDER_MISSING_IID_KEY);
            if ( szTmp[0] )

```

## Appendix A - Application Source Code

```
throw new CWEBCLNT_ERR(
ERR_NEWORDER_ITEMID_WITHOUT_SUPPW );

        GetKeyValue(&ptr, szQty[i], szTmp, sizeof(szTmp),
ERR_NEWORDER_MISSING_QTY_KEY);
        if ( szTmp[0] )
                throw new CWEBCLNT_ERR(
ERR_NEWORDER_QTY_WITHOUT_SUPPW );
    }
    if ( items == 0 )
        throw new CWEBCLNT_ERR( ERR_NEWORDER_NOITEMS_ENTERED );
}

pNewOrderData->o_ol_cnt = items;
}

/* FUNCTION: GetPaymentData
 * PURPOSE:      This function extracts and validates the payment form data from an
http command string.
 * ARGUMENTS:   LPSTR                lpszQueryString        client
browser http command string        PAYMENT_DATA        *pPaymentData
        pointer to payment data structure
 */

void GetPaymentData(LPSTR lpszQueryString, PAYMENT_DATA *pPaymentData)
{
    char    szTmp[26];
    char    *ptr = lpszQueryString;
    BOOL    bCustIdBlank;

    pPaymentData->d_id = GetIntKeyValue(&ptr, "DID*", ERR_PAYMENT_MISSING_DID_KEY,
ERR_PAYMENT_DISTRICT_INVALID);

    GetKeyValue(&ptr, "CID*", szTmp, sizeof(szTmp), ERR_PAYMENT_MISSING_CID_KEY);
    if ( szTmp[0] == 0 )
    {
        bCustIdBlank = TRUE;
        pPaymentData->c_id = 0;
    }
    else
    {
        // parse customer id and verify that last name was NOT entered
        bCustIdBlank = FALSE;
        if ( !IsNumeric(szTmp) )
            throw new CWEBCLNT_ERR( ERR_PAYMENT_CUSTOMER_INVALID );
        pPaymentData->c_id = atoi(szTmp);
    }

    pPaymentData->c_w_id = GetIntKeyValue(&ptr, "CWI*",
ERR_PAYMENT_MISSING_CWI_KEY, ERR_PAYMENT_CWI_INVALID);
    pPaymentData->c_d_id = GetIntKeyValue(&ptr, "CDI*",
ERR_PAYMENT_MISSING_CDI_KEY, ERR_PAYMENT_CDI_INVALID);

    if ( bCustIdBlank )
    {
        // customer id is blank, so last name must be entered
        GetKeyValue(&ptr, "CLT*", szTmp, sizeof(szTmp),
ERR_PAYMENT_MISSING_CLT_KEY);
        if ( szTmp[0] == 0 )
            throw new CWEBCLNT_ERR( ERR_PAYMENT_MISSING_CID_CLT );
        _strupr( szTmp );
    }
}
```

```
if ( strlen(pPaymentData->c_last) > LAST_NAME_LEN )
    throw new CWEBCLNT_ERR( ERR_PAYMENT_LAST_NAME_TO_LONG );
strcpy(pPaymentData->c_last, szTmp);
}
else
{
    // parse customer id and verify that last name was NOT entered
    GetKeyValue(&ptr, "CLT*", szTmp, sizeof(szTmp),
ERR_PAYMENT_MISSING_CLT_KEY);
    if ( szTmp[0] != 0 )
        throw new CWEBCLNT_ERR( ERR_PAYMENT_CID_AND_CLT );
}

GetKeyValue(&ptr, "HAM*", szTmp, sizeof(szTmp), ERR_PAYMENT_MISSING_HAM_KEY);
if (!IsDecimal(szTmp))
    throw new CWEBCLNT_ERR( ERR_PAYMENT_HAM_INVALID );
pPaymentData->h_amount = atof(szTmp);
if ( pPaymentData->h_amount >= 10000.00 || pPaymentData->h_amount < 0 )
    throw new CWEBCLNT_ERR( ERR_PAYMENT_HAM_RANGE );
}

/* FUNCTION: GetOrderStatusData
 * PURPOSE:      This function extracts and validates the payment form data from an
http command string.
 * ARGUMENTS:   LPSTR                lpszQueryString        client
browser http command string        ORDER_STATUS_DATA        *pOrderStatusData
        pointer to order status data structure
 */

void GetOrderStatusData(LPSTR lpszQueryString, ORDER_STATUS_DATA *pOrderStatusData)
{
    char    szTmp[26];
    char    *ptr = lpszQueryString;

    pOrderStatusData->d_id = GetIntKeyValue(&ptr, "DID*",
ERR_ORDERSTATUS_MISSING_DID_KEY, ERR_ORDERSTATUS_DID_INVALID);

    GetKeyValue(&ptr, "CID*", szTmp, sizeof(szTmp),
ERR_ORDERSTATUS_MISSING_CID_KEY);
    if ( szTmp[0] == 0 )
    {
        // customer id is blank, so last name must be entered
        pOrderStatusData->c_id = 0;
        GetKeyValue(&ptr, "CLT*", szTmp, sizeof(szTmp),
ERR_ORDERSTATUS_MISSING_CLT_KEY);
        if ( szTmp[0] == 0 )
            throw new CWEBCLNT_ERR( ERR_ORDERSTATUS_MISSING_CID_CLT );
        _strupr( szTmp );
        if ( strlen(pOrderStatusData->c_last) > LAST_NAME_LEN )
            throw new CWEBCLNT_ERR( ERR_ORDERSTATUS_CLT_RANGE );
        strcpy(pOrderStatusData->c_last, szTmp);
    }
    else
    {
        // parse customer id and verify that last name was NOT entered
        if ( !IsNumeric(szTmp) )
            throw new CWEBCLNT_ERR( ERR_ORDERSTATUS_CID_INVALID );
        pOrderStatusData->c_id = atoi(szTmp);
        GetKeyValue(&ptr, "CLT*", szTmp, sizeof(szTmp),
ERR_ORDERSTATUS_MISSING_CLT_KEY);
        if ( szTmp[0] != 0 )
            throw new CWEBCLNT_ERR( ERR_ORDERSTATUS_CID_AND_CLT );
    }
}

/* FUNCTION: BOOL IsNumeric(char *ptr)
```

## Appendix A - Application Source Code

```
*
* PURPOSE:      This function determines if a string is numeric. It fails if any
characters other
                than numeric and null terminator are present.
*
* ARGUMENTS:   char          *ptr      pointer to string to check.
*
* RETURNS:     BOOL          FALSE    if string is not all numeric
                TRUE            if string contains
only numeric characters i.e. '0' - '9'
*/

BOOL IsNumeric(char *ptr)
{
    if ( *ptr == 0 )
        return FALSE;

    while( *ptr && isdigit(*ptr) )
        ptr++;
    return ( !*ptr );
}

/* FUNCTION: BOOL IsDecimal(char *ptr)
*
* PURPOSE:      This function determines if a string is a non-negative decimal value.
                It fails if any characters other than a series of numbers followed by
                a decimal point, another series of numbers, and a null
terminator are present.
*
* ARGUMENTS:   char          *ptr      pointer to string to check.
*
* RETURNS:     BOOL          FALSE    if string is not a valid non-negative
decimal value
                TRUE            if string is OK
*/

BOOL IsDecimal(char *ptr)
{
    char *dotptr;
    BOOL bValid;

    if ( *ptr == 0 )
        return FALSE;

    // find decimal point
    dotptr = strchr( ptr, '.' );
    if (dotptr == NULL)
        // no decimal point, so just check for numeric
        return IsNumeric(ptr);
    *dotptr = 0; // temporarily replace decimal with a terminator

    if ( *ptr != 0 )
        bValid = IsNumeric(ptr);
    // string starts with decimal point
    else if (*(dotptr+1) == 0)
        return FALSE; // nothing but a decimal point is bad
    else
        bValid = TRUE;

    if (*(dotptr+1) != 0)
        // check text after decimal point
        bValid &= IsNumeric(dotptr+1);
}
```

```
*dotptr = '.'; // replace decimal point
return bValid;
}
```

### isapi\_dll/src/resource.h

```
//{{NO_DEPENDENCIES}}
// Microsoft Developer Studio generated include file.
// Used by tpcc.rc
//
#define IDD_DIALOG1                101

// Next default values for new objects
//
#ifdef APSTUDIO_INVOKED
#ifdef APSTUDIO_READONLY_SYMBOLS
#define _APS_NEXT_RESOURCE_VALUE    102
#define _APS_NEXT_COMMAND_VALUE    40001
#define _APS_NEXT_CONTROL_VALUE    1000
#define _APS_NEXT_SYMED_VALUE      101
#endif
#endif
```

### common/src/ReadRegistry.cpp

```
/*      FILE:          READREGISTRY.CPP
*
*                               Microsoft TPC-C Kit Ver. 4.20.000
*                               Copyright Microsoft, 1999
*
*      All Rights Reserved
*
*                               not yet audited
*
*      PURPOSE:  Implementation for TPC-C Tuxedo class.
*      Contact:  Charles Levine (clevine@microsoft.com)
*
*      Change history:
*      4.20.000 - first version
*/

/* FUNCTION: ReadTPCCRegistrySettings
*
* PURPOSE:      This function reads the NT registry for startup parameters. There
parameters are
                under the TPCC key.
*
* RETURNS      FALSE = no errors
                TRUE  = error reading registry
*/
BOOL ReadTPCCRegistrySettings( TPCCREGISTRYDATA *pReg )
{
    HKEY    hKey;
    DWORD  size;
    DWORD  type;
    DWORD  dwTmp;
```

## Appendix A - Application Source Code

```
char    szTmp[256];

if ( RegOpenKeyEx(HKEY_LOCAL_MACHINE, "SOFTWARE\\Microsoft\\TPCC", 0, KEY_READ,
&hKey) != ERROR_SUCCESS )
    return TRUE;

// determine database protocol to use; may be either ODBC or DBLIB
pReg->eDB_Protocol = Unspecified;
size = sizeof(szTmp);
if ( RegQueryValueEx(hKey, "DB_Protocol", 0, &type, (BYTE *)&szTmp, &size) ==
ERROR_SUCCESS )
{
    if ( !strcmp(szTmp, szDBNames[ODBC]) )
        pReg->eDB_Protocol = ODBC;
    else if ( !strcmp(szTmp, szDBNames[DBLIB]) )
        pReg->eDB_Protocol = DBLIB;
}

pReg->eTxnMon = None;
// determine txn monitor to use; may be either TUXEDO, or blank
size = sizeof(szTmp);
if ( RegQueryValueEx(hKey, "TxnMonitor", 0, &type, (BYTE *)&szTmp, &size) ==
ERROR_SUCCESS )
{
    if ( !strcmp(szTmp, szTxnMonNames[TUXEDO]) )
        pReg->eTxnMon = TUXEDO;
    else if ( !strcmp(szTmp, szTxnMonNames[ENCINA]) )
        pReg->eTxnMon = ENCINA;
    else if ( !strcmp(szTmp, szTxnMonNames[COM]) )
        pReg->eTxnMon = COM;
}

pReg->bCOM_SinglePool = FALSE;
size = sizeof(szTmp);
if ( RegQueryValueEx(hKey, "COM_SinglePool", 0, &type, (BYTE *)&szTmp, &size)
== ERROR_SUCCESS )
{
    if ( !strcmp(szTmp, "YES") )
        pReg->bCOM_SinglePool = TRUE;
}

pReg->dwMaxConnections = 0;
size = sizeof(dwTmp);
if ( ( RegQueryValueEx(hKey, "MaxConnections", 0, &type, (LPBYTE)&dwTmp, &size)
== ERROR_SUCCESS )
    && (type == REG_DWORD) )
    pReg->dwMaxConnections = dwTmp;

pReg->dwMaxPendingDeliveries = 0;
size = sizeof(dwTmp);
if ( ( RegQueryValueEx(hKey, "MaxPendingDeliveries", 0, &type, (LPBYTE)&dwTmp,
&size) == ERROR_SUCCESS )
    && (type == REG_DWORD) )
    pReg->dwMaxPendingDeliveries = dwTmp;

pReg->dwNumberOfDeliveryThreads = 0;
size = sizeof(dwTmp);
if ( ( RegQueryValueEx(hKey, "NumberOfDeliveryThreads", 0, &type,
(LPBYTE)&dwTmp, &size) == ERROR_SUCCESS )
    && (type == REG_DWORD) )
    pReg->dwNumberOfDeliveryThreads = dwTmp;

size = sizeof( pReg->szPath );
```

```
if ( RegQueryValueEx(hKey, "Path", 0, &type, (BYTE *)&pReg->szPath, &size) !=
ERROR_SUCCESS )
    pReg->szPath[0] = 0;

size = sizeof( pReg->szDbServer );
if ( RegQueryValueEx(hKey, "DbServer", 0, &type, (BYTE *)&pReg->szDbServer,
&size) != ERROR_SUCCESS )
    pReg->szDbServer[0] = 0;

size = sizeof( pReg->szDbName );
if ( RegQueryValueEx(hKey, "DbName", 0, &type, (BYTE *)&pReg->szDbName, &size)
!= ERROR_SUCCESS )
    pReg->szDbName[0] = 0;

size = sizeof( pReg->szDbUser );
if ( RegQueryValueEx(hKey, "DbUser", 0, &type, (BYTE *)&pReg->szDbUser, &size)
!= ERROR_SUCCESS )
    pReg->szDbUser[0] = 0;

size = sizeof( pReg->szDbPassword );
if ( RegQueryValueEx(hKey, "DbPassword", 0, &type, (BYTE *)&pReg->szDbPassword,
&size) != ERROR_SUCCESS )
    pReg->szDbPassword[0] = 0;

RegCloseKey(hKey);

return FALSE;
}
```

### common/src/ReadRegistry.h

```
/* FILE: ReadRegistry.h
 * Microsoft TPC-C Kit Ver. 4.20.000
 * Copyright Microsoft, 1999
 * All Rights Reserved
 * not audited
 * PURPOSE: Header for registry related code.
 * Change history:
 * 4.20.000 - first version
 */

enum DBPROTOCOL { Unspecified, ODBC, DBLIB };
const char *szDBNames[] = { "Unspecified", "ODBC", "DBLIB" };

enum TXNMON { None, TUXEDO, ENCINA, COM };
const char *szTxnMonNames[] = { "NONE", "TUXEDO", "ENCINA", "COM" };

//This structure defines the data necessary to keep distinct for each terminal or client
connection.
typedef struct _TPCCREGISTRYDATA
{
    enum DBPROTOCOL eDB_Protocol;
    enum TXNMON eTxnMon;
    BOOL bCOM_SinglePool;
    DWORD dwMaxConnections;
    DWORD dwMaxPendingDeliveries;
```

# Appendix A - Application Source Code

```
    DWORD dwNumberOfDeliveryThreads;
    char szPath[128];
    char szDbServer[32];
    char szDbName[32];
    char szDbUser[32];
    char szDbPassword[32];
} TPCCREGISTRYDATA, *PTPCCREGISTRYDATA;

BOOL ReadTPCCRegistrySettings( TPCCREGISTRYDATA *pReg );
```

## common/src/error.h

```
/*      FILE:          ERROR.H
 *
 *      Microsoft TPC-C Kit Ver. 4.20.000
 *      Copyright Microsoft, 1999
 *
 *      All Rights Reserved
 *
 *      Version 4.10.000 audited by Richard Gimarc,
 *      Performance Metrics, 3/17/99
 *
 *      PURPOSE:  Header file for error exception classes.
 *
 *      Change history:
 *      4.20.000 - updated rev number to match kit
 *      4.21.000 - fixed bug: ~CBaseErr needed to be declared virtual
 */

#pragma once

#ifndef _INC_STRING
#include <string.h>
#endif

const int m_szMsg_size = 512;
const int m_szApp_size = 64;
const int m_szLoc_size = 64;

//error message structure used in ErrorText routines
typedef struct _SERRORMSG
{
    int          iError;                //error id of
message        char      szMsg[256];   //message to sent to browser
} SERRORMSG;

#define ERR_FATAL_LEVEL          1
#define ERR_WARNING_LEVEL       2
#define ERR_INFORMATION_LEVEL3

#define ERR_TYPE_LOGIC           -1      //logic error in program; internal error
#define ERR_SUCCESS              0      //success (a non-error error)
#define ERR_BAD_ITEM_ID         1      //expected abort record in txnRecord
#define ERR_TYPE_DELIVERY_POST  2      //expected delivery post failed
```

```
#define ERR_TYPE_WEBDLL          3      //tpcc web generated error
#define ERR_TYPE_SQL            4      //sql server generated error
#define ERR_TYPE_DBLIB          5      //dblib generated error
#define ERR_TYPE_ODBC           6      //odbc generated error
#define ERR_TYPE_SOCKET         7      //error on communication socket client rte only
#define ERR_TYPE_DEADLOCK      8      //dblib and odbc only deadlock condition
#define ERR_TYPE_COM           9      //error from COM call
#define ERR_TYPE_TUXEDO        10      //tuxedo error
#define ERR_TYPE_OS            11      //operating system error
#define ERR_TYPE_MEMORY        12      //memory allocation error
#define ERR_TYPE_TPCC_ODBC     13      //error from tpcc odbc txn module
#define ERR_TYPE_TPCC_DBLIB    14      //error from tpcc dblib txn module
#define ERR_TYPE_DELISRV       15      //delivery server error
#define ERR_TYPE_TXNLOG        16      //txn log error
#define ERR_TYPE_BCCONN        17      //Benchcraft connection class
#define ERR_TYPE_TPCC_CONN     18      //Benchcraft connection class
#define ERR_TYPE_ENCINA        19      //Encina error
#define ERR_TYPE_COMPONENT     20      //error from COM component
#define ERR_TYPE_RTE           21      //Benchcraft rte
#define ERR_TYPE_AUTOMATION     22      //Benchcraft automation errors

class CBaseErr
{
public:
    char      *m_szApp;
    char      *m_szMsg;
    char      *m_szLoc; // code location where the error occurred
    int       m_idMsg;

    CBaseErr(void)
    {
        m_idMsg          = 0;
        m_szMsg          = new char[m_szMsg_size];
        m_szApp          = new char[m_szApp_size];
        m_szLoc          = NULL;
        m_szMsg[0]       = 0;
        m_szApp[0]       = 0;
    }

    GetModuleFileName(GetModuleHandle(NULL), m_szApp, m_szApp_size);
}
```

## Appendix A - Application Source Code

```
virtual ~CBaseErr(void)
{
    if (m_szMsg)
        delete [] m_szMsg;
    if (m_szApp)
        delete [] m_szApp;
    if (m_szLoc)
        delete [] m_szLoc;
};

CBaseErr(int idMsg)
{
    m_idMsg          = idMsg;
    m_szApp          = new char[m_szApp_size];
    m_szMsg          = new char[m_szMsg_size];
    m_szLoc          = NULL;

    GetModuleFileName(GetModuleHandle(NULL), m_szApp, m_szApp_size);
    LoadString(GetModuleHandle(NULL), idMsg, m_szMsg, m_szMsg_size);
}

CBaseErr(LPCTSTR szMsg)
{
    m_idMsg          = 0;
    m_szApp          = new char[m_szApp_size];
    m_szMsg          = new char[m_szMsg_size];
    m_szLoc          = NULL;

    GetModuleFileName(GetModuleHandle(NULL), m_szApp, m_szApp_size);
    strcpy(m_szMsg, szMsg);
}

void SetError(char *szMsg, LPCTSTR szLocation)
{
    if (szMsg != NULL)
        strcpy(m_szMsg, szMsg);
    else
        m_szMsg[0] = 0;

    if (szLocation != NULL)
    {
        delete [] m_szLoc;
        m_szLoc = new char[strlen(szLocation)+1];
        strcpy(m_szLoc, szLocation);
    }
    else
    {
        delete [] m_szLoc;
        m_szLoc = NULL;
    }
}

virtual void Draw(HWND hwnd, LPCTSTR szStr = NULL)
{
    int      j;
    char     szTmp[512];

    if (szStr)
        j = wsprintf(szTmp, "%s\n", szStr);
    if (m_szLoc)
        j += wsprintf(szTmp+j, "Location=%s\n", m_szLoc);
    if (m_szMsg)
        j += wsprintf(szTmp+j, "%s\n", m_szMsg);
}
```

```
        ::MessageBox(hwnd, szTmp, m_szApp, MB_OK);
    }

    char *GetApp(void) { return m_szApp; }
    char *GetMsg(void) { return m_szMsg; }
    char *GetLocation(void) { return m_szLoc; }

    virtual int ErrorType() = 0; // a value which distinguishes the kind of error
    that occurred
    virtual int ErrorNum() = 0; // an error value specific to the error
    type
    virtual char *ErrorText() = 0; // a string (i.e., human readable)
    representation of the error
};

class CSocketErr : public CBaseErr
{
public:
    enum Action
    {
        eNone,
        eSend,
        eSocket,
        eConnect
    };

    CSocketErr(Action eAction, LPCTSTR szLocation);
    CSocketErr(int iError) { m_errId = iError; };
    int      m_errId;
    Action   m_eAction;

    int ErrorType() { return ERR_TYPE_SOCKET; };
    int ErrorNum() { return m_errId; };
    char *ErrorText(void);
};

class CSystemErr : public CBaseErr
{
public:
    enum Action
    {
        eNone,
        eTransactNamedPipe,
        eWaitNamedPipe,
        eSetNamedPipeHandleState,
        eCreateFile,
        eCreateProcess,
        eCallNamedPipe,
        eCreateEvent,
        eCreateThread,
        eVirtualAlloc,
        eReadFile,
        eWriteFile,
        eMapViewOfFile,
        eCreateFileMapping,
        eInitializeSecurityDescriptor,
        eSetSecurityDescriptorDacl,
        eCreateNamedPipe,
        eConnectNamedPipe,
        eWaitForSingleObject,
        eRegOpenKeyEx,
    };
};
```

## Appendix A - Application Source Code

```
        eRegQueryValueEx,
    };

    CSystemErr(Action eAction, LPCTSTR szLocation);

    void Draw(HWND hwnd, LPCTSTR szStr = NULL);

    int          m_errId;
    Action      m_eAction;

    int ErrorType() { return ERR_TYPE_OS; }
    int ErrorNum() { return m_errId; }
    char *ErrorText() { return m_szMsg; }
};

class CMemoryErr : public CBaseErr
{
public:
    CMemoryErr(void);

    int ErrorType() { return ERR_TYPE_MEMORY; }
    int ErrorNum() { return 0; }
    char *ErrorText() { return "Insufficient Memory to continue."; }
};
```

### common/src/trans.h

```
/*      FILE:          TRANS.H
 *
 *      Microsoft TPC-C Kit Ver. 4.20.000
 *      Copyright Microsoft, 1999
 *
 *      All Rights Reserved
 *
 *      Version 4.10.000 audited by Richard Gimarc,
 *
 *      Performance Metrics, 3/17/99
 *
 *      PURPOSE:  Header file for TPC-C structure templates.
 *
 *      Change history:
 *      *      4.20.000 - updated rev number to match kit
 */
#pragma once

// String length constants
#define SERVER_NAME_LEN      20
#define DATABASE_NAME_LEN   20
#define USER_NAME_LEN       20
#define PASSWORD_LEN       20
#define TABLE_NAME_LEN    20
#define I_DATA_LEN          50
#define I_NAME_LEN         24
#define BRAND_LEN           1
#define LAST_NAME_LEN       16
#define W_NAME_LEN          10
#define ADDRESS_LEN         20
#define STATE_LEN           2
#define ZIP_LEN             9
#define S_DIST_LEN         24
#define S_DATA_LEN         50
```

```
#define D_NAME_LEN          10
#define FIRST_NAME_LEN     16
#define MIDDLE_NAME_LEN    2
#define PHONE_LEN          16
#define DATETIME_LEN       30
#define CREDIT_LEN         2
#define C_DATA_LEN         250
#define H_DATA_LEN         24
#define DIST_INFO_LEN      24
#define MAX_OL_NEW_ORDER_ITEMS 15
#define MAX_OL_ORDER_STATUS_ITEMS 15
#define STATUS_LEN         25
#define OL_DIST_INFO_LEN   24

// TIMESTAMP_STRUCT is provided by the ODBC header file sqltypes.h, but is not available
// when compiling with dblib, so redefined here. Note: we are using the symbol
// "__SQLTYPES"
// (declared in sqltypes.h) as a way to determine if TIMESTAMP_STRUCT has been declared.
#ifdef __SQLTYPES
    typedef struct
    {
        short          /* SQLSMALLINT */ year;
        unsigned short /* SQLUSMALLINT */ month;
        unsigned short /* SQLUSMALLINT */ day;
        unsigned short /* SQLUSMALLINT */ hour;
        unsigned short /* SQLUSMALLINT */ minute;
        unsigned short /* SQLUSMALLINT */ second;
        unsigned long  /* SQLINTEGER */ fraction;
    } TIMESTAMP_STRUCT;
#elseif
// possible values for exec_status_code after transaction completes
enum EXEC_STATUS
{
    eOK, // 0 "Transaction committed."
    eInvalidItem, // 1 "Item number is not valid."
    eDeliveryFailed // 2 "Delivery Post Failed."
};

// transaction structures
typedef struct
{
    // input params
    short          ol_supply_w_id;
    long           ol_i_id;
    short          ol_quantity;

    // output params
    char           ol_i_name[I_NAME_LEN+1];
    char           ol_brand_generic[BRAND_LEN+1];
    double         ol_i_price;
    double         ol_amount;
    short          ol_stock;
} OL_NEW_ORDER_DATA;

typedef struct
{
    // input params
    short          w_id;
    short          d_id;
    long           c_id;
    short          o_ol_cnt;
```

## Appendix A - Application Source Code

```
// output params
EXEC_STATUS          exec_status_code;
char                 c_last[LAST_NAME_LEN+1];
char                 c_credit[CREDIT_LEN+1];
double              c_discount;
double              w_tax;
double              d_tax;
long                o_id;
short               o_commit_flag;
TIMESTAMP_STRUCT    o_entry_d;
short               o_all_local;
double              total_amount;
OL_NEW_ORDER_DATA   OL[MAX_OL_NEW_ORDER_ITEMS];
} NEW_ORDER_DATA, *PNEW_ORDER_DATA;

typedef struct
{
    // input params
    short           w_id;
    short           d_id;
    long            c_id;
    short           c_d_id;
    short           c_w_id;
    double          h_amount;
    char            c_last[LAST_NAME_LEN+1];

    // output params
    EXEC_STATUS     exec_status_code;
    TIMESTAMP_STRUCT h_date;
    char            w_street_1[ADDRESS_LEN+1];
    char            w_street_2[ADDRESS_LEN+1];
    char            w_city[ADDRESS_LEN+1];
    char            w_state[STATE_LEN+1];
    char            w_zip[ZIP_LEN+1];
    char            d_street_1[ADDRESS_LEN+1];
    char            d_street_2[ADDRESS_LEN+1];
    char            d_city[ADDRESS_LEN+1];
    char            d_state[STATE_LEN+1];
    char            d_zip[ZIP_LEN+1];
    char            c_first[FIRST_NAME_LEN+1];
    char            c_middle[MIDDLE_NAME_LEN + 1];
    char            c_street_1[ADDRESS_LEN+1];
    char            c_street_2[ADDRESS_LEN+1];
    char            c_city[ADDRESS_LEN+1];
    char            c_state[STATE_LEN+1];
    char            c_zip[ZIP_LEN+1];
    char            c_phone[PHONE_LEN+1];
    TIMESTAMP_STRUCT c_since;
    char            c_credit[CREDIT_LEN+1];
    double          c_credit_lim;
    double          c_discount;
    double          c_balance;
    char            c_data[200+1];
} PAYMENT_DATA, *PPAYMENT_DATA;

typedef struct
{
    long            ol_i_id;
    short           ol_supply_w_id;
    short           ol_quantity;
    double          ol_amount;
    TIMESTAMP_STRUCT ol_delivery_d;
} OL_ORDER_STATUS_DATA;
```

```
typedef struct
{
    // input params
    short           w_id;
    short           d_id;
    long            c_id;
    char            c_last[LAST_NAME_LEN+1];

    // output params
    EXEC_STATUS     exec_status_code;
    char            c_first[FIRST_NAME_LEN+1];
    char            c_middle[MIDDLE_NAME_LEN+1];
    double          c_balance;
    long            o_id;
    TIMESTAMP_STRUCT o_entry_d;
    short           o_carrier_id;
    OL_ORDER_STATUS_DATA OL[MAX_OL_ORDER_STATUS_ITEMS];
    short           o_ol_cnt;
} ORDER_STATUS_DATA, *PORDER_STATUS_DATA;

typedef struct
{
    // input params
    short           w_id;
    short           o_carrier_id;

    // output params
    EXEC_STATUS     exec_status_code;
    SYSTEMTIME      queue_time;
    long            o_id[10]; // id's of
    delivered orders for districts 1 to 10
} DELIVERY_DATA, *PDELIVERY_DATA;

//This structure is used for posting delivery transactions and for writing them to the
delivery server.
typedef struct _DELIVERY_TRANSACTION
{
    SYSTEMTIME      queue; //time delivery transaction
    short           w_id; //delivery warehouse
    short           o_carrier_id; //carrier id
} DELIVERY_TRANSACTION;

typedef struct
{
    // input params
    short           w_id;
    short           d_id;
    short           threshold;

    // output params
    EXEC_STATUS     exec_status_code;
    long            low_stock;
} STOCK_LEVEL_DATA, *PSTOCK_LEVEL_DATA;
```

### common/src/txn\_base.h

```
/* FILE: TXN_BASE.H
 * Microsoft TPC-C Kit Ver. 4.20.000
 * Copyright Microsoft, 1999
 * All Rights Reserved
```

## Appendix A - Application Source Code

```
*
*                                     Version 4.10.000 audited by Richard Gimarc,
Performance Metrics, 3/17/99
*
*     PURPOSE: Header file for TPC-C txn class implementation.
*
* Change history:
*     4.20.000 - updated rev number to match kit
*/

#pragma once

// need to declare functions for import, unless define has already been created
// by the DLL's .cpp module for export.
#ifndef DllDecl
#define DllDecl __declspec( dllimport )
#endif

class DllDecl CTPCC_BASE
{
public:
    CTPCC_BASE(void) {};
    virtual ~CTPCC_BASE(void) {};

    virtual PNEW_ORDER_DATA      BuffAddr_NewOrder()
    = 0;
    virtual PPAYMENT_DATA        BuffAddr_Payment()
    = 0;
    virtual PDELIVERY_DATA       BuffAddr_Delivery()
    = 0;
    virtual PSTOCK_LEVEL_DATA     BuffAddr_StockLevel()      = 0;
    virtual PORDER_STATUS_DATA    BuffAddr_OrderStatus()     = 0;

    virtual void NewOrder          () = 0;
    virtual void Payment            () = 0;
    virtual void Delivery           () = 0;
    virtual void StockLevel         () = 0;
    virtual void OrderStatus        () = 0;
};
```

### db\_dblib\_dll/src/tpcc\_dblib.cpp

```
/*     FILE:          TPCC_DBLIB.CPP
*
*     Microsoft TPC-C Kit Ver. 4.20.000
*     Copyright Microsoft, 1999
*
*     All Rights Reserved
*
*                                     Version 4.10.000 audited by Richard Gimarc,
Performance Metrics, 3/17/99
*
*     PURPOSE: Implements dblib calls for TPC-C txns.
*     Contact: Charles Levine (clevine@microsoft.com)
*
* Change history:
*     4.20.000 - updated rev number to match kit
*     4.10.001 - not deleting error class in catch handler on deadlock
retry;
*
*                                     not a functional bug, but a memory leak
```

```
*                                     - had to tweak some declarations to compile with
latest SDK; no functional change
*/

#include <windows.h>
#include <stdio.h>
#include <assert.h>

#define DENTWIN32
#include <sqlfront.h>
#include <sqldb.h>

#ifdef ICECAP
#include <icapexp.h>
#endif

// need to declare functions for export
#define DllDecl __declspec( dllexport )

#include "..\..\common\src\error.h"
#include "..\..\common\src\trans.h"
#include "..\..\common\src\txn_base.h"
#include "tpcc_dblib.h"

#define DEFCLPACKSIZE 4096

// version string; must match return value from tpcc_version stored proc
const char sVersion[] = "4.10.000";

const          iMaxRetries = 10;          // how many retries on
deadlock
static long    iConnectionCount = 0; // number of current dblib connections

BOOL WINAPI DllMain(HMODULE hModule, DWORD ul_reason_for_call, LPVOID lpReserved)
{
    switch( ul_reason_for_call )
    {
        case DLL_PROCESS_ATTACH:
            DisableThreadLibraryCalls(hModule);
            dbinit(); // initialize dblib
            break;

        case DLL_PROCESS_DETACH:
            dbexit(); // close all dblib
            structures/connections
            break;

        default:
            /* nothing */;
    }
    return TRUE;
}

int err_handler(DBPROCESS *dbproc, int severity, int dberr, int oserr, LPCSTR dberrstr,
LPCSTR oserrstr)
{
    CTPCC_DBLIB *pConn;

    assert(dbproc != NULL);
    pConn = (CTPCC_DBLIB*)dbgetuserdata(dbproc);

    if (pConn != NULL)
```

## Appendix A - Application Source Code

```
{
    pConn->SetDbLibError( severity, dberr, oserr, dberrstr, oserrstr );
}
return INT_CANCEL;
}

/* FUNCTION: int msg_handler(DBPROCESS *dbproc, DBINT msgno, int msgstate, int severity,
char *msgtext)
*
* PURPOSE:      This function handles DB-Library SQL Server error messages
*
* ARGUMENTS:    DBPROCESS      *dbproc          DBPROCESS id
pointer
*              DBINT          msgno
*              int            msgstate
*              int            severity
*              char           *msgtext
*              printable message description
*
* RETURNS:      int            INT_CONTINUE
continue if error is SQLETIME else INT_CANCEL action
*
* INT_CANCEL    cancel operation
*
* COMMENTS:     This function also sets the dead lock dbproc variable if necessary.
*/

// typedef INT (SQLAPI *DBMSGHANDLE_PROC)(PDBPROCESS, DBINT, INT, INT, LPCSTR, LPCSTR,
LPCSTR, DBUSMALLINT);

int msg_handler(DBPROCESS *dbproc, DBINT msgno, int msgstate, int severity,
LPCSTR msgtext, LPCSTR srvname, LPCSTR procname,
DBUSMALLINT line)
{
    CTPCC_DBLIB          *pConn;

    assert(dbproc != NULL);
    pConn = (CTPCC_DBLIB*)dbgetuserdata(dbproc);

    if (pConn != NULL)
    {
        pConn->SetSqlError( msgno, msgstate, severity, msgtext );
    }

    return 0;
}

/* FUNCTION: void UtilStrCpy(char * pDest, char * pSrc, int n)
*
* PURPOSE:      This function copies n characters from string pSrc to pDst and places
a
*              null character at the end of the destination string.
*
* ARGUMENTS:    char           *pDest  destination string pointer
*              char           *pSrc   source
string pointer
*              int            n
*              number of characters to copy
*
* RETURNS:      None
*
* COMMENTS:     Unlike strncpy this function ensures that the result string is
*              always null terminated.
*/

inline static void UtilStrCpy(char * pDest, const BYTE * pSrc, int n)
{
    strncpy(pDest, (char *)pSrc, n);
    pDest[n] = '\0';

    return;
}

/* FUNCTION: CTPCC_DBLIB_ERR::ErrorText
*
*/
char* CTPCC_DBLIB_ERR::ErrorText(void)
{
    int i;

    static SERRORMSG errorMsgs[] =
    {
        { ERR_WRONG_SP_VERSION,          "Wrong version of stored
procs on database server" },
        { ERR_INVALID_CUST,              "Invalid Customer id,name." },
        { ERR_NO_SUCH_ORDER,             "No orders found for
customer." },
        { 0,                              "" }
    };

    static char szNotFound[] = "Unknown error number.";

    for(i=0; errorMsgs[i].szMsg[0]; i++)
    {
        if ( m_errno == errorMsgs[i].iError )
            break;
    }

    if ( !errorMsgs[i].szMsg[0] )
        return szNotFound;

    else
        return errorMsgs[i].szMsg;
}

// wrapper routine for class constructor
__declspec(dllexport) CTPCC_DBLIB* CTPCC_DBLIB_new(
LPCSTR szServer,          // name of SQL server
LPCSTR szUser,           // user name for login
LPCSTR szPassword,       // password for login
LPCSTR szHost,           // workstation name; shows up in
sp_who; max 30 chars, only first 10 kept by SQL Server
LPCSTR szDatabase )      // name of database to use
{
    return new CTPCC_DBLIB( szServer, szUser, szPassword, szHost, szDatabase );
}

CTPCC_DBLIB::CTPCC_DBLIB (
```

```
CTPCC_DBLIB (
    pConn->SetDbLibError( severity, dberr, oserr, dberrstr, oserrstr );
}
return INT_CANCEL;
}

/* FUNCTION: int msg_handler(DBPROCESS *dbproc, DBINT msgno, int msgstate, int severity,
char *msgtext)
*
* PURPOSE:      This function handles DB-Library SQL Server error messages
*
* ARGUMENTS:    DBPROCESS      *dbproc          DBPROCESS id
pointer
*              DBINT          msgno
*              int            msgstate
*              int            severity
*              char           *msgtext
*              printable message description
*
* RETURNS:      int            INT_CONTINUE
continue if error is SQLETIME else INT_CANCEL action
*
* INT_CANCEL    cancel operation
*
* COMMENTS:     This function also sets the dead lock dbproc variable if necessary.
*/

// typedef INT (SQLAPI *DBMSGHANDLE_PROC)(PDBPROCESS, DBINT, INT, INT, LPCSTR, LPCSTR,
LPCSTR, DBUSMALLINT);

int msg_handler(DBPROCESS *dbproc, DBINT msgno, int msgstate, int severity,
LPCSTR msgtext, LPCSTR srvname, LPCSTR procname,
DBUSMALLINT line)
{
    CTPCC_DBLIB          *pConn;

    assert(dbproc != NULL);
    pConn = (CTPCC_DBLIB*)dbgetuserdata(dbproc);

    if (pConn != NULL)
    {
        pConn->SetSqlError( msgno, msgstate, severity, msgtext );
    }

    return 0;
}

/* FUNCTION: void UtilStrCpy(char * pDest, char * pSrc, int n)
*
* PURPOSE:      This function copies n characters from string pSrc to pDst and places
a
*              null character at the end of the destination string.
*
* ARGUMENTS:    char           *pDest  destination string pointer
*              char           *pSrc   source
string pointer
*              int            n
*              number of characters to copy
*
* RETURNS:      None
*
* COMMENTS:     Unlike strncpy this function ensures that the result string is
*              always null terminated.
*/

inline static void UtilStrCpy(char * pDest, const BYTE * pSrc, int n)
{
    strncpy(pDest, (char *)pSrc, n);
    pDest[n] = '\0';

    return;
}

/* FUNCTION: CTPCC_DBLIB_ERR::ErrorText
*
*/
char* CTPCC_DBLIB_ERR::ErrorText(void)
{
    int i;

    static SERRORMSG errorMsgs[] =
    {
        { ERR_WRONG_SP_VERSION,          "Wrong version of stored
procs on database server" },
        { ERR_INVALID_CUST,              "Invalid Customer id,name." },
        { ERR_NO_SUCH_ORDER,             "No orders found for
customer." },
        { 0,                              "" }
    };

    static char szNotFound[] = "Unknown error number.";

    for(i=0; errorMsgs[i].szMsg[0]; i++)
    {
        if ( m_errno == errorMsgs[i].iError )
            break;
    }

    if ( !errorMsgs[i].szMsg[0] )
        return szNotFound;

    else
        return errorMsgs[i].szMsg;
}

// wrapper routine for class constructor
__declspec(dllexport) CTPCC_DBLIB* CTPCC_DBLIB_new(
LPCSTR szServer,          // name of SQL server
LPCSTR szUser,           // user name for login
LPCSTR szPassword,       // password for login
LPCSTR szHost,           // workstation name; shows up in
sp_who; max 30 chars, only first 10 kept by SQL Server
LPCSTR szDatabase )      // name of database to use
{
    return new CTPCC_DBLIB( szServer, szUser, szPassword, szHost, szDatabase );
}

CTPCC_DBLIB::CTPCC_DBLIB (
```

## Appendix A - Application Source Code

```
LPCSTR szServer,           // name of SQL server
LPCSTR szUser,            // user name for login
LPCSTR szPassword,       // password for login
LPCSTR szHost,           // workstation name; shows up in
sp_who; max 30 chars, only first 10 kept by SQL Server
LPCSTR szDatabase )      // name of database to use
{
    LOGINREC *login;
    const BYTE *pData;

    // initialization
    m_dbproc = NULL;
    m_DbLibErr = (CDBLIBERR*)NULL;
    m_SqlErr = (CSQLERR*)NULL;

    m_MaxRetries = 10;           // how many retries on deadlock

    // increase max number of connections if getting close
    if ( dbgetmaxprocs() < (iConnectionCount+5) )
    {
        if ( dbsetmaxprocs(iConnectionCount+10) == FAIL )
            ThrowError(CDBLIBERR::eDbSetMaxProcs);
    }

    // allocate a login structure
    login = dblogin();
    if (login == NULL)
        ThrowError(CDBLIBERR::eLogin);
    InterlockedIncrement( &iConnectionCount );

    // register error and message handler functions
    if (dbprocerrhandle(login, err_handler) == NULL)
        ThrowError(CDBLIBERR::eDbProcHandler);

    if (dbprocmshandle(login, msg_handler) == NULL)
        ThrowError(CDBLIBERR::eDbProcHandler);

    DBSETUSER(login, szUser);
    DBSETLPWD(login, szPassword);
    DBSETHOST(login, szHost);
    DBSETPACKET(login, (unsigned short)DEFCLPACKSIZE);
    DBSETLVERSION(login, DBVER60); // use dblink ver 6.0 client
behavior

    // set time to wait for login
    if (dbsetlogintime(60) == FAIL)
        ThrowError(CDBLIBERR::eDbSet);

    // set time to wait for statement execution
    if (dbsettime(180) == FAIL)
        ThrowError(CDBLIBERR::eDbSet);

    m_dbproc = dbopen(login, szServer);

    // deallocate login structure before checking for success
    dbfreelogin( login );

    if (m_dbproc == NULL)
        ThrowError(CDBLIBERR::eDbOpen);

    // save address of class instance so that the message and error handler
    // can get to data.
```

```
dbsetuserdata(m_dbproc, (LPVOID)this);

    // Use the the right database
    if (dbuse(m_dbproc, szDatabase) == FAIL)
        ThrowError(CDBLIBERR::eDbUse);

    dbcmd(m_dbproc, "set nocount on "); // do not return
row counts
    dbcmd(m_dbproc, "set XACT_ABORT ON"); // rollback transaction on
abort

    if (dbsqlEXEC(m_dbproc) == FAIL)
        ThrowError(CDBLIBERR::eDbSqlExec);

    DiscardNextResults(2);

    // verify that version of stored procs on server is correct
    dbrpcinit(m_dbproc, "tpcc_version", 0);

    if (dbrpcEXEC(m_dbproc) == FAIL)
        ThrowError(CDBLIBERR::eDbRpcExec);

    if (dbresults(m_dbproc) != SUCCEED)
        ThrowError(CDBLIBERR::eDbResults);

    if (dbnextrow(m_dbproc) != REG_ROW)
        ThrowError(CDBLIBERR::eDbNextRow);

    char szSrvVersion[16];
    pData=dbdata(m_dbproc, 1);
    if (pData)
        UtilStrCpy(szSrvVersion, pData, dbdatlen(m_dbproc, 1));
    else
        szSrvVersion[0]=0;
    if (strcmp(szSrvVersion,sVersion))
        throw new CTPCC_DBLIB_ERR( CTPCC_DBLIB_ERR::ERR_WRONG_SP_VERSION );

    DiscardNextRows(0);
    DiscardNextResults(0);
}

CTPCC_DBLIB::~CTPCC_DBLIB( void )
{
    // close db connection and deallocate resources
    dbclose(m_dbproc);
    InterlockedDecrement( &iConnectionCount );
    if (m_DbLibErr != NULL)
        delete m_DbLibErr;
    if (m_SqlErr != NULL)
        delete m_SqlErr;
}

void CTPCC_DBLIB::SetDbLibError(int severity, int dberr, int oserr, LPCSTR dberrstr,
LPCSTR oserrstr)
{
    delete m_DbLibErr;
    m_DbLibErr = new CDBLIBERR(CDBLIBERR::eUnknown, severity, dberr, oserr);

    if (dberrstr != NULL)
    {
        m_DbLibErr->m_dberrstr = new char[ strlen(dberrstr)+1 ];
```

## Appendix A - Application Source Code

```
        strcpy( m_DbLibErr->m_gberrstr, dberrstr );
    }
    if (oserrstr != NULL)
    {
        m_DbLibErr->m_oserrstr = new char[ strlen(oserrstr)+1 ];
        strcpy( m_DbLibErr->m_oserrstr, oserrstr );
    }
}

void CTPCC_DBLIB::SetSqlError( int /*DBINT*/ msgno, int msgstate, int severity, LPCSTR
msgtext )
{
    if (m_SqlErr == NULL)
        m_SqlErr = new CSQLErr();

    m_SqlErr->m_msgno = msgno;
    m_SqlErr->m_msgstate = msgstate;
    m_SqlErr->m_severity = severity;

    delete [] m_SqlErr->m_msgtext;
    if (msgtext != NULL)
    {
        m_SqlErr->m_msgtext = new char[ strlen(msgtext)+1 ];
        strcpy( m_SqlErr->m_msgtext, msgtext );
    }
}

void CTPCC_DBLIB::ThrowError( CDBLIBERR::ACTION eAction )
{
    // discard anything still in return buffer
    DiscardNextRows(-1);
    DiscardNextResults(-1);

    // check for SQL Server error first; if yes, throw it and ignore any DBLib
error.
    if (m_SqlErr != NULL)
    {
        CSQLErr *pSqlErr;
        pSqlErr = m_SqlErr;
        m_SqlErr = NULL; // clear our pointer to instance; catch handler
will delete
        throw pSqlErr;
    }

    CDBLIBERR *pDbLibErr;
    if (m_DbLibErr == NULL)
        // this case isn't expected to happen, since it means that an error
was returned
        // but the error handlers were not called.
        pDbLibErr = new CDBLIBERR(eAction);
    else
    {
        pDbLibErr = m_DbLibErr;
        pDbLibErr->m_eAction = eAction;
        m_DbLibErr = NULL; // clear our pointer to instance; catch
handler will delete
    }
    throw pDbLibErr;
}
}
```

```
// Read and discard rows until no more. Throw an exception if number of rows read
doesn't
// match number of rows expected. The row count will be ignored if the expected count
value
// passed in is negative. A typical use of this routine is to verify that there are no
more
// rows to be read.
void CTPCC_DBLIB::DiscardNextRows(int iExpectedCount)
{
    int iRowsRead = 0;
    RETCODE rc;

    while (TRUE)
    {
        rc = dbnextrow(m_dbproc);
        if (rc == NO_MORE_ROWS)
            break;
        if (rc == FAIL)
        {
            if (iExpectedCount >= 0)
                ThrowError(CDBLIBERR::eDbNextRow);
            else
                break;
        }
        iRowsRead++;
    }

    if ((iExpectedCount >= 0) &&
        (iExpectedCount != iRowsRead))
        ThrowError(CDBLIBERR::eWrongRowCount);
}

// Read and discard results until no more. Throw an exception if number of result sets
read doesn't
// match number expected. The result set count will be ignored if the expected count
value
// passed in is negative. A typical use of this routine is to verify that there are no
more
// result sets to be read.
void CTPCC_DBLIB::DiscardNextResults(int iExpectedCount)
{
    int iResultsRead = 0;
    RETCODE rc;

    while (TRUE)
    {
        rc = dbresults(m_dbproc);
        if (rc == NO_MORE_RESULTS)
            break;
        if (rc == FAIL)
        {
            if (iExpectedCount >= 0)
                ThrowError(CDBLIBERR::eDbResults);
            else
                break;
        }

        DiscardNextRows(-1);
        iResultsRead++;
    }

    if ((iExpectedCount >= 0) &&
        (iExpectedCount != iResultsRead))
}
```

# Appendix A - Application Source Code

```
        ThrowError(CDBLIBERR::eWrongRowCount);
    }
}

void CTPCC_DBLIB::StockLevel()
{
    int                iTryCount = 0;
    const BYTE        *pData;

    ResetError();

    while (TRUE)
    {
        try
        {
            dbrpcinit(m_dbproc, "tpcc_stocklevel", 0);

            dbrpcparam(m_dbproc, NULL, 0, SQLINT2, -1, -1, (BYTE *)
&m_txn.StockLevel.w_id); // @w_id smallint
            dbrpcparam(m_dbproc, NULL, 0, SQLINT1, -1, -1, (BYTE *)
&m_txn.StockLevel.d_id); // @d_id tinyint
            dbrpcparam(m_dbproc, NULL, 0, SQLINT2, -1, -1, (BYTE *)
&m_txn.StockLevel.threshold); // @threshold smallint

            if (dbrpcexec(m_dbproc) == FAIL)
                ThrowError(CDBLIBERR::eDbRpcExec);

            if (dbresults(m_dbproc) != SUCCEED)
                ThrowError(CDBLIBERR::eDbResults);

            if (dbnextrow(m_dbproc) != REG_ROW)
                ThrowError(CDBLIBERR::eDbNextRow);

            if (pData=dbdata(m_dbproc, 1))
                m_txn.StockLevel.low_stock = *((long *) pData);

            DiscardNextRows(0);
            DiscardNextResults(0);

            m_txn.StockLevel.exec_status_code = eOK;
            return;
        }
        catch (CSQLERR *e)
        {
            if ((e->m_msgno != 1205) || (++iTryCount > iMaxRetries))
                throw;

            // hit deadlock; backoff for increasingly longer period
            delete e;
            Sleep(10 * iTryCount);
        }
    } // while (TRUE)
}

void CTPCC_DBLIB::NewOrder()
{
    int                i;
    DBINT              commit_flag;
    DBDATETIME         datetime;
    DBDATERECD         daterec;

    int                iTryCount = 0;
    const BYTE        *pData;
```

```
    ResetError();

    while (TRUE)
    {
        try
        {
            dbrpcinit(m_dbproc, "tpcc_neworder", 0);

            dbrpcparam(m_dbproc, NULL, 0, SQLINT2, -1, -1, (BYTE *)
&m_txn.NewOrder.w_id);
            dbrpcparam(m_dbproc, NULL, 0, SQLINT1, -1, -1, (BYTE *)
&m_txn.NewOrder.d_id);
            dbrpcparam(m_dbproc, NULL, 0, SQLINT4, -1, -1, (BYTE *)
&m_txn.NewOrder.c_id);
            dbrpcparam(m_dbproc, NULL, 0, SQLINT1, -1, -1, (BYTE *)
&m_txn.NewOrder.o_ol_cnt);

            // check whether any order lines are for a remote warehouse
            m_txn.NewOrder.o_all_local = 1;
            for (i = 0; i < m_txn.NewOrder.o_ol_cnt; i++)
            {
                if (m_txn.NewOrder.OL[i].ol_supply_w_id !=
                    m_txn.NewOrder.w_id)
                {
                    m_txn.NewOrder.o_all_local = 0; // at
                    least one remote warehouse
                    break;
                }
            }
            dbrpcparam(m_dbproc, NULL, 0, SQLINT1, -1, -1, (BYTE *)
&m_txn.NewOrder.o_all_local);

            for (i = 0; i < m_txn.NewOrder.o_ol_cnt; i++)
            {
                dbrpcparam(m_dbproc, NULL, 0, SQLINT4, -1, -1,
(BYTE *) &m_txn.NewOrder.OL[i].ol_i_id);
                dbrpcparam(m_dbproc, NULL, 0, SQLINT2, -1, -1,
(BYTE *) &m_txn.NewOrder.OL[i].ol_supply_w_id);
                dbrpcparam(m_dbproc, NULL, 0, SQLINT2, -1, -1,
(BYTE *) &m_txn.NewOrder.OL[i].ol_quantity);
            }

            if (dbrpcexec(m_dbproc) == FAIL)
                ThrowError(CDBLIBERR::eDbRpcExec);

            // Get order line results
            m_txn.NewOrder.total_amount = 0;
            for (i = 0; i < m_txn.NewOrder.o_ol_cnt; i++)
            {
                if (dbresults(m_dbproc) != SUCCEED)
                    ThrowError(CDBLIBERR::eDbResults);

                if (dbnumcols(m_dbproc) != 5)
                    ThrowError(CDBLIBERR::eWrongNumCols);

                if (dbnextrow(m_dbproc) != REG_ROW)
                    ThrowError(CDBLIBERR::eDbNextRow);

                if (pData=dbdata(m_dbproc, 1))
                    UtilStrCpy(m_txn.NewOrder.OL[i].ol_i_name, pData, dbdatlen(m_dbproc, 1));
            }
        }
    }
}
```

## Appendix A - Application Source Code

```
        if(pData=dbdata(m_dbproc, 2))
            m_txn.NewOrder.OL[i].ol_stock =
(* (DBSMALLINT *) pData);
        if(pData=dbdata(m_dbproc, 3))
            UtilStrCpy(m_txn.NewOrder.OL[i].ol_brand_generic, pData, dbdatlen(m_dbproc,
3));
        if(pData=dbdata(m_dbproc, 4))
            dbconvert(m_dbproc, SQLNUMERIC, pData,
dbdatlen(m_dbproc,4),
            SQLFLT8, (BYTE
*)&m_txn.NewOrder.OL[i].ol_i_price, 8);
        if(pData=dbdata(m_dbproc, 5))
            dbconvert(m_dbproc, SQLNUMERIC, pData,
dbdatlen(m_dbproc,5),
            SQLFLT8, (BYTE
*)&m_txn.NewOrder.OL[i].ol_amount, 8);
        m_txn.NewOrder.total_amount =
m_txn.NewOrder.total_amount + m_txn.NewOrder.OL[i].ol_amount;
        DiscardNextRows(0);
    }
    // get remaining values for w_tax, d_tax, o_id, c_last,
c_discount, c_credit, o_entry_d, commit_flag
    if (dbresults(m_dbproc) != SUCCEED)
        ThrowError(CDBLIBERR::eDbResults);
    if (dbnextrow(m_dbproc) != REG_ROW)
        ThrowError(CDBLIBERR::eDbNextRow);
    if (dbnumcols(m_dbproc) != 8)
        ThrowError(CDBLIBERR::eWrongNumCols);
    if (pData=dbdata(m_dbproc, 1))
        dbconvert(m_dbproc, SQLNUMERIC, pData,
dbdatlen(m_dbproc,1), SQLFLT8, (BYTE *)&m_txn.NewOrder.w_tax, 8);
    if (pData=dbdata(m_dbproc, 2))
        dbconvert(m_dbproc, SQLNUMERIC, pData,
dbdatlen(m_dbproc,2), SQLFLT8, (BYTE *)&m_txn.NewOrder.d_tax, 8);
    if (pData=dbdata(m_dbproc, 3))
        m_txn.NewOrder.o_id = (*(DBINT *) pData);
    if (pData=dbdata(m_dbproc, 4))
        UtilStrCpy(m_txn.NewOrder.c_last, pData,
dbdatlen(m_dbproc, 4));
    if (pData=dbdata(m_dbproc, 5))
        dbconvert(m_dbproc, SQLNUMERIC, pData,
dbdatlen(m_dbproc,5), SQLFLT8, (BYTE *)&m_txn.NewOrder.c_discount, 8);
    if (pData=dbdata(m_dbproc, 6))
        UtilStrCpy(m_txn.NewOrder.c_credit, pData,
dbdatlen(m_dbproc, 6));
    if (pData=dbdata(m_dbproc, 7))
    {
        datetime = *(DBDATETIME *) pData);
        dbdatecrack(m_dbproc, &daterec, &datetime);
        m_txn.NewOrder.o_entry_d.year = daterec.year;
        m_txn.NewOrder.o_entry_d.month = daterec.month;
```

```
        m_txn.NewOrder.o_entry_d.day = daterec.day;
        m_txn.NewOrder.o_entry_d.hour = daterec.hour;
        m_txn.NewOrder.o_entry_d.minute = daterec.minute;
        m_txn.NewOrder.o_entry_d.second = daterec.second;
    }
    if (pData=dbdata(m_dbproc, 8))
        commit_flag = *(DBTINYINT *) pData);
    DiscardNextRows(0);
    DiscardNextResults(0);
    if (commit_flag == 1)
    {
        m_txn.NewOrder.total_amount *= ((1 +
m_txn.NewOrder.w_tax + m_txn.NewOrder.d_tax) * (1 - m_txn.NewOrder.c_discount));
        m_txn.NewOrder.exec_status_code = eOK;
    }
    else
        m_txn.NewOrder.exec_status_code = eInvalidItem;
    return;
}
catch (CSQLERR *e)
{
    if ((e->m_msgno != 1205) || (++iTryCount > iMaxRetries))
        throw;
    // hit deadlock; backoff for increasingly longer period
    delete e;
    Sleep(10 * iTryCount);
}
// while (TRUE)
}

void CTPCC_DBLIB::Payment()
{
    DBDATETIME datetime;
    DBDATEREC daterec;
    int iTryCount = 0;
    const BYTE *pData;
    ResetError();
    while (TRUE)
    {
        try
        {
            dbrpcinit(m_dbproc, "tpcc_payment", 0);
            dbrpcparam(m_dbproc, NULL, 0, SQLINT2, -1, -1, (BYTE *)
&m_txn.Payment.w_id);
            dbrpcparam(m_dbproc, NULL, 0, SQLINT2, -1, -1, (BYTE *)
&m_txn.Payment.c_w_id);
            dbrpcparam(m_dbproc, NULL, 0, SQLFLT8, -1, -1, (BYTE *)
&m_txn.Payment.h_amount);
            dbrpcparam(m_dbproc, NULL, 0, SQLINT1, -1, -1, (BYTE *)
&m_txn.Payment.d_id);
            dbrpcparam(m_dbproc, NULL, 0, SQLINT1, -1, -1, (BYTE *)
&m_txn.Payment.c_d_id);
```

## Appendix A - Application Source Code

```
&m_txn.Payment.c_id);
    dbrpcparam(m_dbproc, NULL, 0, SQLINT4, -1, -1, (BYTE *)
    // if customer id is zero, then payment is by name
    if (m_txn.Payment.c_id == 0)
        dbrpcparam(m_dbproc, NULL, 0, SQLCHAR, -1,
    strlen(m_txn.Payment.c_last), (unsigned char *)m_txn.Payment.c_last);

    if (dbrpcexec(m_dbproc) == FAIL)
        ThrowError(CDBLIBERR::eDbRpcExec);

    if (dbresults(m_dbproc) != SUCCEED)
        ThrowError(CDBLIBERR::eDbResults);

    if (dbnextrow(m_dbproc) != REG_ROW)
        ThrowError(CDBLIBERR::eDbNextRow);

    if (dbnumcols(m_dbproc) != 27)
        ThrowError(CDBLIBERR::eWrongNumCols);

    if (pData=dbdata(m_dbproc, 1))
        m_txn.Payment.c_id = *((DBINT *) pData);
    if (pData=dbdata(m_dbproc, 2))
        UtilStrCpy(m_txn.Payment.c_last, pData,
    dbdatlen(m_dbproc, 2));

    if (pData=dbdata(m_dbproc, 3))
    {
        datetime = *((DBDATETIME *) pData);
        dbdatecrack(m_dbproc, &daterec, &datetime);
        m_txn.Payment.h_date.year = daterec.year;
        m_txn.Payment.h_date.month = daterec.month;
        m_txn.Payment.h_date.day = daterec.day;
        m_txn.Payment.h_date.hour = daterec.hour;
        m_txn.Payment.h_date.minute = daterec.minute;
        m_txn.Payment.h_date.second = daterec.second;
    }
    if (pData=dbdata(m_dbproc, 4))
        UtilStrCpy(m_txn.Payment.w_street_1, pData,
    dbdatlen(m_dbproc, 4));

    if (pData=dbdata(m_dbproc, 5))
        UtilStrCpy(m_txn.Payment.w_street_2, pData,
    dbdatlen(m_dbproc, 5));

    if (pData=dbdata(m_dbproc, 6))
        UtilStrCpy(m_txn.Payment.w_city, pData,
    dbdatlen(m_dbproc, 6));

    if (pData=dbdata(m_dbproc, 7))
        UtilStrCpy(m_txn.Payment.w_state, pData,
    dbdatlen(m_dbproc, 7));

    if (pData=dbdata(m_dbproc, 8))
        UtilStrCpy(m_txn.Payment.w_zip, pData,
    dbdatlen(m_dbproc, 8));

    if (pData=dbdata(m_dbproc, 9))
        UtilStrCpy(m_txn.Payment.d_street_1, pData,
    dbdatlen(m_dbproc, 9));

    if (pData=dbdata(m_dbproc, 10))
        UtilStrCpy(m_txn.Payment.d_street_2, pData,
    dbdatlen(m_dbproc, 10));

    if (pData=dbdata(m_dbproc, 11))
        UtilStrCpy(m_txn.Payment.d_city, pData,
    dbdatlen(m_dbproc, 11));

    if (pData=dbdata(m_dbproc, 12))
        UtilStrCpy(m_txn.Payment.d_state, pData,
```

```
    if (pData=dbdata(m_dbproc, 13))
        UtilStrCpy(m_txn.Payment.d_zip, pData,
    dbdatlen(m_dbproc, 13));

    if (pData=dbdata(m_dbproc, 14))
        UtilStrCpy(m_txn.Payment.c_first, pData,
    dbdatlen(m_dbproc, 14));

    if (pData=dbdata(m_dbproc, 15))
        UtilStrCpy(m_txn.Payment.c_middle, pData,
    dbdatlen(m_dbproc, 15));

    if (pData=dbdata(m_dbproc, 16))
        UtilStrCpy(m_txn.Payment.c_street_1, pData,
    dbdatlen(m_dbproc, 16));

    if (pData=dbdata(m_dbproc, 17))
        UtilStrCpy(m_txn.Payment.c_street_2, pData,
    dbdatlen(m_dbproc, 17));

    if (pData=dbdata(m_dbproc, 18))
        UtilStrCpy(m_txn.Payment.c_city, pData,
    dbdatlen(m_dbproc, 18));

    if (pData=dbdata(m_dbproc, 19))
        UtilStrCpy(m_txn.Payment.c_state, pData,
    dbdatlen(m_dbproc, 19));

    if (pData=dbdata(m_dbproc, 20))
        UtilStrCpy(m_txn.Payment.c_zip, pData,
    dbdatlen(m_dbproc, 20));

    if (pData=dbdata(m_dbproc, 21))
        UtilStrCpy(m_txn.Payment.c_phone, pData,
    dbdatlen(m_dbproc, 21));

    if (pData=dbdata(m_dbproc, 22))
    {
        datetime = *((DBDATETIME *) pData);
        dbdatecrack(m_dbproc, &daterec, &datetime);
        m_txn.Payment.c_since.year = daterec.year;
        m_txn.Payment.c_since.month = daterec.month;
        m_txn.Payment.c_since.day = daterec.day;
        m_txn.Payment.c_since.hour = daterec.hour;
        m_txn.Payment.c_since.minute = daterec.minute;
        m_txn.Payment.c_since.second = daterec.second;
    }
    if (pData=dbdata(m_dbproc, 23))
        UtilStrCpy(m_txn.Payment.c_credit, pData,
    dbdatlen(m_dbproc, 23));

    if (pData=dbdata(m_dbproc, 24))
        dbconvert(m_dbproc, SQLNUMERIC, pData,
    dbdatlen(m_dbproc,24), SQLFLT8, (BYTE *)&m_txn.Payment.c_credit_lim, 8);
    if (pData=dbdata(m_dbproc, 25))
        dbconvert(m_dbproc, SQLNUMERIC, pData,
    dbdatlen(m_dbproc,25), SQLFLT8, (BYTE *)&m_txn.Payment.c_discount, 8);
    if (pData=dbdata(m_dbproc, 26))
        dbconvert(m_dbproc, SQLNUMERIC, pData,
    dbdatlen(m_dbproc,26), SQLFLT8, (BYTE *)&m_txn.Payment.c_balance, 8);
    if (pData=dbdata(m_dbproc, 27))
        UtilStrCpy(m_txn.Payment.c_data, pData,
    dbdatlen(m_dbproc, 27));

    DiscardNextRows(0);
    DiscardNextResults(0);

    if (m_txn.Payment.c_id == 0)
        throw new CTPCC_DBLIB_ERR(
    CTPCC_DBLIB_ERR::ERR_INVALID_CUST );
    else
        m_txn.Payment.exec_status_code = eOK;
```

## Appendix A - Application Source Code

```
        return;
    }
    catch (CSQLERR *e)
    {
        if ((e->m_msgno != 1205) || (++iTryCount > iMaxRetries))
            throw;

        // hit deadlock; backoff for increasingly longer period
        delete e;
        Sleep(10 * iTryCount);
    }
    // while (TRUE)
}

void CTPCC_DBLIB::OrderStatus()
{
    int i;
    DBDATETIME datetime;
    DBDATERECD daterec;

    int iTryCount = 0;
    RETCODE rc;
    const BYTE *pData;

    ResetError();

    while (TRUE)
    {
        try
        {
            dbrpcinit(m_dbproc, "tpcc_orderstatus", 0);
            dbrpcparam(m_dbproc, NULL, 0, SQLINT2, -1, -1, (BYTE *)
&m_txn.OrderStatus.w_id);
            dbrpcparam(m_dbproc, NULL, 0, SQLINT1, -1, -1, (BYTE *)
&m_txn.OrderStatus.d_id);
            dbrpcparam(m_dbproc, NULL, 0, SQLINT4, -1, -1, (BYTE *)
&m_txn.OrderStatus.c_id);

            // if customer id is zero, then order status is by name
            if (m_txn.OrderStatus.c_id == 0)
                dbrpcparam(m_dbproc, NULL, 0, SQLCHAR, -1,
strlen(m_txn.OrderStatus.c_last), (unsigned char *)m_txn.OrderStatus.c_last);

            if (dbrpcexec(m_dbproc) == FAIL)
                ThrowError(CDBLIBERR::eDbRpcExec);

            // Get order lines
            if (dbresults(m_dbproc) != SUCCEED)
            {
                if ((m_DbLibErr == NULL) && (m_SqlErr == NULL))
                    throw new CTPCC_DBLIB_ERR(
CTPCC_DBLIB_ERR::ERR_NO_SUCH_ORDER );
                else
                    ThrowError(CDBLIBERR::eDbResults);
            }

            if (dbnumcols(m_dbproc) != 5)
                ThrowError(CDBLIBERR::eWrongNumCols);
        }
    }
}
```

```
        i = 0;
        while (TRUE)
        {
            rc = dbnextrow(m_dbproc);
            if (rc == NO_MORE_ROWS)
                break;
            if (rc != REG_ROW)
                ThrowError(CDBLIBERR::eDbNextRow);

            if (pData=dbdata(m_dbproc, 1))
                m_txn.OrderStatus.OL[i].ol_supply_w_id =

            if (pData=dbdata(m_dbproc, 2))
                m_txn.OrderStatus.OL[i].ol_i_id =

            if (pData=dbdata(m_dbproc, 3))
                m_txn.OrderStatus.OL[i].ol_quantity =

            if (pData=dbdata(m_dbproc, 4))
                dbconvert(m_dbproc, SQLNUMERIC, pData,
SQLFLT8, (BYTE
*)&m_txn.OrderStatus.OL[i].ol_amount, 8);
            if (pData=dbdata(m_dbproc, 5))
            {
                datetime = *((DBDATETIME *) pData);
                dbdatecrack(m_dbproc, &daterec,

                m_txn.OrderStatus.OL[i].ol_delivery_d.year = daterec.year;
                m_txn.OrderStatus.OL[i].ol_delivery_d.month = daterec.month;
                m_txn.OrderStatus.OL[i].ol_delivery_d.day = daterec.day;
                m_txn.OrderStatus.OL[i].ol_delivery_d.hour = daterec.hour;
                m_txn.OrderStatus.OL[i].ol_delivery_d.minute = daterec.minute;
                m_txn.OrderStatus.OL[i].ol_delivery_d.second = daterec.second;
            }
            i++;
            m_txn.OrderStatus.o_ol_cnt = i;

            if (dbresults(m_dbproc) != SUCCEED)
                ThrowError(CDBLIBERR::eDbResults);

            if (dbnextrow(m_dbproc) != REG_ROW)
                ThrowError(CDBLIBERR::eDbNextRow);

            if (dbnumcols(m_dbproc) != 8)
                ThrowError(CDBLIBERR::eWrongNumCols);

            if (pData=dbdata(m_dbproc, 1))
                m_txn.OrderStatus.c_id = (*(DBINT *) pData);
            if (pData=dbdata(m_dbproc, 2))
                UtilStrCpy(m_txn.OrderStatus.c_last, pData,
dbdatlen(m_dbproc,2));

            if (pData=dbdata(m_dbproc, 3))
```

## Appendix A - Application Source Code

```
        UtilStrCpy(m_txn.OrderStatus.c_first, pData,
dbdatlen(m_dbproc,3));
        if(pData=dbdata(m_dbproc, 4))
            UtilStrCpy(m_txn.OrderStatus.c_middle, pData,
dbdatlen(m_dbproc, 4));
        if(pData=dbdata(m_dbproc, 5))
        {
            datetime = *((DBDATETIME *) pData);
            dbdatecrack(m_dbproc, &daterec, &datetime);
            m_txn.OrderStatus.o_entry_d.year =
            m_txn.OrderStatus.o_entry_d.month =
            m_txn.OrderStatus.o_entry_d.day = daterec.day;
            m_txn.OrderStatus.o_entry_d.hour =
            m_txn.OrderStatus.o_entry_d.minute =
            m_txn.OrderStatus.o_entry_d.second =
        }
        if(pData=dbdata(m_dbproc, 6))
            m_txn.OrderStatus.o_carrier_id = (*(DBSMALLINT *)
pData);
        if(pData=dbdata(m_dbproc, 7))
            dbconvert(m_dbproc, SQLNUMERIC, pData,
dbdatlen(m_dbproc,7),
                SQLFLT8, (BYTE
*)&m_txn.OrderStatus.c_balance, 8);
        if(pData=dbdata(m_dbproc, 8))
            m_txn.OrderStatus.o_id = (*(DBINT *) pData);

        DiscardNextRows(0);
        DiscardNextResults(0);

        if (m_txn.OrderStatus.o_ol_cnt == 0)
            throw new CTPCC_DBLIB_ERR(
CTPCC_DBLIB_ERR::ERR_NO_SUCH_ORDER );
        else if (m_txn.OrderStatus.c_id == 0 &&
m_txn.OrderStatus.c_last[0] == 0)
            throw new CTPCC_DBLIB_ERR(
CTPCC_DBLIB_ERR::ERR_INVALID_CUST );
        else
            m_txn.OrderStatus.exec_status_code = eOK;

        return;
    }
    catch (CSQLERR *e)
    {
        if ((e->m_msgno != 1205) || (++iTryCount > iMaxRetries))
            throw;

        // hit deadlock; backoff for increasingly longer period
        delete e;
        Sleep(10 * iTryCount);
    }
} // while (TRUE)

void CTPCC_DBLIB::Delivery()
{
```

```
        int
        int
        const BYTE
        *pData;

        ResetError();

        while (TRUE)
        {
            try
            {
                dbrpcinit(m_dbproc, "tpcc_delivery", 0);
                dbrpcparam(m_dbproc, NULL, 0, SQLINT2, -1, -1, (BYTE *)
&m_txn.Delivery.w_id);
                dbrpcparam(m_dbproc, NULL, 0, SQLINT1, -1, -1, (BYTE *)
&m_txn.Delivery.o_carrier_id);

                if (dbrpcexec(m_dbproc) == FAIL)
                    ThrowError(CDBLIBERR::eDbRpcExec);

                if (dbresults(m_dbproc) != SUCCEED)
                    ThrowError(CDBLIBERR::eDbResults);

                if (dbnextrow(m_dbproc) != REG_ROW)
                    ThrowError(CDBLIBERR::eDbNextRow);

                if (dbnumcols(m_dbproc) != 10)
                    ThrowError(CDBLIBERR::eWrongNumCols);

                for (i=0; i<10; i++)
                {
                    if (pData = dbdata(m_dbproc, i+1))
                        m_txn.Delivery.o_id[i] = (*(DBINT
*)pData);
                }

                DiscardNextRows(0);
                DiscardNextResults(0);

                m_txn.Delivery.exec_status_code = eOK;
                return;
            }
            catch (CSQLERR *e)
            {
                if ((e->m_msgno != 1205) || (++iTryCount > iMaxRetries))
                    throw;

                // hit deadlock; backoff for increasingly longer period
                delete e;
                Sleep(10 * iTryCount);
            }
        } // while (TRUE)

    void CTPCC_DBLIB::ResetError()
    {
        if (m_DbLibErr != NULL)
        {
            delete m_DbLibErr;
            m_DbLibErr = (CDBLIBERR*)NULL;
        }

        if (m_SqlErr != NULL)
```

## Appendix A - Application Source Code

```
    {
        delete m_SqlErr;
        m_SqlErr = (CSQLERR*)NULL;
    }
    return;
}
```

### db\_dblib\_dll/src/tpcc\_dblib.h

```
/*      FILE:          TPCC_DBLIB.H
 *
 *      Microsoft TPC-C Kit Ver. 4.20.000
 *      Copyright Microsoft, 1999
 *
 *      All Rights Reserved
 *
 *      Version 4.10.000 audited by Richard Gimarc,
 *      Performance Metrics, 3/17/99
 *
 *      PURPOSE:  Header file for TPC-C txn class implementation.
 *
 *      Change history:
 *      4.20.000 - updated rev number to match kit
 */
#pragma once

#ifndef PDBPROCESS
#define DBPROCESS void // dbprocess structure type
typedef DBPROCESS * PDBPROCESS;
#endif

// need to declare functions for import, unless define has already been created
// by the DLL's .cpp module for export.
#ifndef DllDecl
#define DllDecl __declspec( dllimport )
#endif

class CSQLERR : public CBaseErr
{
public:
    CSQLERR(void)
    {
        m_msgno = 0;
        m_msgstate = 0;
        m_severity = 0;
        m_msgtext = NULL;
    };

    ~CSQLERR()
    {
        delete [] m_msgtext;
    };

    int m_msgno;
    int m_msgstate;
    int m_severity;
    char *m_msgtext;

    int ErrorType() {return ERR_TYPE_SQL;};
    int ErrorNum() {return m_msgno;};
};
```

```
char *ErrorText() {return m_msgtext;};
};

class CDBLIBERR : public CBaseErr
{
public:
    enum ACTION
    {
        eNone,
        eUnknown,
        eLogin, // error from
        eDbOpen, // error from dbopen
        eDbUse, // error from dbuse
        eDbSqlExec, // error from
        eDbSet, // error from one
        eDbNextRow, // error from
        eWrongRowCount, // more or less rows returned
        eWrongNumCols, // more or less columns
        eDbResults, // error from
        eDbRpcExec, // error from
        eDbSetMaxProcs, // error from dbsetmaxprocs
        eDbProcHandler // error from either
    };

    dblogin
    dbsqlxec
    of the dbset* routines
    dbnextrow
    than expected
    returned than expected
    dbresults
    dbrpcxec
    dbprocerrhandle or dbprocmsghandle
    oserr = 0)

    CDBLIBERR(ACTION eAction, int severity = 0, int dberror = 0, int
    {
        m_eAction = eAction;
        m_severity = severity;
        m_dberror = dberror;
        m_oserr = oserr;

        m_dberrstr = NULL;
        m_oserrstr = NULL;
    };

    ~CDBLIBERR()
    {
        delete [] m_dberrstr;
        delete [] m_oserrstr;
    };

    ACTION m_eAction;
    int m_severity;
    int m_dberror;
    int m_oserr;
    char *m_dberrstr;
    char *m_oserrstr;

    int ErrorType() {return ERR_TYPE_DBLIB;};
    int ErrorNum() {return m_dberror;};
    char *ErrorText() {return m_dberrstr;};
};
```

## Appendix A - Application Source Code

```
};
class CTPCC_DBLIB_ERR : public CBaseErr
{
public:
enum CTPCC_DBLIB_ERRS
{
ERR_WRONG_SP_VERSION = 1, // "Wrong version of stored
procs on database server"
ERR_INVALID_CUST, // "Invalid
Customer id,name."
ERR_NO_SUCH_ORDER // "No orders found
for customer."
};
CTPCC_DBLIB_ERR( int iErr ) { m_errno = iErr; };
int m_errno;
int ErrorType() {return ERR_TYPE_TPCC_DBLIB;};
int ErrorNum() {return m_errno;};
char *ErrorText();
};
class DllDecl CTPCC_DBLIB : public CTPCC_BASE
{
private:
// declare variables and private functions here...
PDBPROCESS m_dbproc;
CDBLIBERR *m_DbLibErr; // not allocated until needed
(maybe never)
CSQLERR *m_SqlErr; // not
allocated until needed (maybe never)
int m_MaxRetries; // retry
count on deadlock
void DiscardNextRows(int iExpectedCount);
void DiscardNextResults(int iExpectedCount);
void ThrowError( CDBLIBERR::ACTION eAction );
void ResetError();
union
{
NEW_ORDER_DATA NewOrder;
PAYMENT_DATA Payment;
DELIVERY_DATA Delivery;
STOCK_LEVEL_DATA StockLevel;
ORDER_STATUS_DATA OrderStatus;
}
m_txn;
public:
CTPCC_DBLIB(LPCSTR szServer, LPCSTR szUser, LPCSTR szPassword, LPCSTR
szHost, LPCSTR szDatabase );
~CTPCC_DBLIB(void);
inline PNEW_ORDER_DATA BuffAddr_NewOrder()
{ return &m_txn.NewOrder; };
inline PPAYMENT_DATA BuffAddr_Payment()
{ return &m_txn.Payment; };
inline PDELIVERY_DATA BuffAddr_Delivery()
{ return &m_txn.Delivery; };
};
```

```
inline PSTOCK_LEVEL_DATA BuffAddr_StockLevel() { return
&m_txn.StockLevel; };
inline PORDER_STATUS_DATA BuffAddr_OrderStatus() { return
&m_txn.OrderStatus; };
void NewOrder ();
void Payment ();
void Delivery ();
void StockLevel ();
void OrderStatus ();
// these are public because they must be called from the dblib
err_handler and msg_hangler
// outside of the class
void SetDbLibError(int severity, int dberr, int oserr, LPCSTR
dberrstr, LPCSTR oserrstr);
void SetSqlError( int msgno, int msgstate, int severity, LPCSTR
msgtext );
};
extern "C" DllDecl CTPCC_DBLIB* CTPCC_DBLIB_new
( LPCSTR szServer, LPCSTR szUser, LPCSTR szPassword, LPCSTR szHost, LPCSTR
szDatabase );
typedef CTPCC_DBLIB* (TYPE_CTPCC_DBLIB)(LPCSTR, LPCSTR, LPCSTR, LPCSTR, LPCSTR);
```

### tm\_com\_dll/src/tpcc\_com.cpp

```
/* FILE: TPCC_COM.CPP
Microsoft TPC-C Kit Ver. 4.20.000
Copyright Microsoft, 1999
All Rights Reserved
not yet audited
PURPOSE: Source file for TPC-C COM+ class implementation.
Contact: Charles Levine (clevine@microsoft.com)
Change history:
4.20.000 - first version
*/
// needed for CoInitializeEx
#define _WIN32_WINNT 0x0400
#include <windows.h>
// need to declare functions for export
#define DllDecl __declspec( dllexport )
#include "..\..\common\src\trans.h" //tpckit transaction header contains
definitions of structures specific to TPC-C
#include "..\..\common\src\error.h"
#include "..\..\common\src\txn_base.h"
#include "tpcc_com.h"
#include "..\..\tpcc_com_ps\src\tpcc_com_ps_i.c"
```

## Appendix A - Application Source Code

```
#include "..\..\tpcc_com_all\src\tpcc_com_all_i.c"

// wrapper routine for class constructor
__declspec(dllexport) CTPCC_COM* CTPCC_COM_new(BOOL bSinglePool)
{
    return new CTPCC_COM(bSinglePool);
}

CTPCC_COM::CTPCC_COM(BOOL bSinglePool)
{
    HRESULT hr = NULL;
    long lRet = 0;
    ULONG ulTmpSize = 0;

    m_pTxn = NULL;
    m_pNewOrder = NULL;
    m_pPayment = NULL;
    m_pStockLevel = NULL;
    m_pOrderStatus = NULL;

    m_bSinglePool = bSinglePool;

    ulTmpSize = (ULONG) sizeof(COM_DATA);
    VariantInit(&m_vTxn);
    m_vTxn.vt = VT_SAFEARRAY;

    m_vTxn.parray = SafeArrayCreateVector(VT_UI1, ulTmpSize, ulTmpSize);
    if (!m_vTxn.parray)
        throw new CCOMERR( E_FAIL );

    memset((void*)m_vTxn.parray->pvData, 0, ulTmpSize);
    m_pTxn = (COM_DATA*)m_vTxn.parray->pvData;

    hr = CoInitializeEx(NULL, COINIT_MULTITHREADED);
    if (FAILED(hr))
    {
        throw new CCOMERR( hr );
    }

    // create components
    if (m_bSinglePool)
    {
        hr = CoCreateInstance(CLSID_TPCC, NULL, CLSCTX_SERVER, IID_ITPCC,
        (void **)&m_pNewOrder);
        if (FAILED(hr))
            throw new CCOMERR(hr);

        // all txns will use same component
        m_pPayment = m_pNewOrder;
        m_pStockLevel = m_pNewOrder;
        m_pOrderStatus = m_pNewOrder;
    }
    else
    {
        // use different components for each txn

        hr = CoCreateInstance(CLSID_NewOrder, NULL, CLSCTX_SERVER, IID_ITPCC,
        (void **)&m_pNewOrder);
        if (FAILED(hr))
            throw new CCOMERR(hr);

        hr = CoCreateInstance(CLSID_Payment, NULL, CLSCTX_SERVER, IID_ITPCC,
        (void **)&m_pPayment);
```

```
        if (FAILED(hr))
            throw new CCOMERR(hr);

        hr = CoCreateInstance(CLSID_StockLevel, NULL, CLSCTX_SERVER,
        IID_ITPCC, (void **)&m_pStockLevel);
        if (FAILED(hr))
            throw new CCOMERR(hr);

        hr = CoCreateInstance(CLSID_OrderStatus, NULL, CLSCTX_SERVER,
        IID_ITPCC, (void **)&m_pOrderStatus);
        if (FAILED(hr))
            throw new CCOMERR(hr);
    }

    // call setcomplete to release each component back into pool
    hr = m_pNewOrder->CallSetComplete();
    if (FAILED(hr))
        throw new CCOMERR(hr);

    if (!m_bSinglePool)
    {
        hr = m_pPayment->CallSetComplete();
        if (FAILED(hr))
            throw new CCOMERR(hr);

        hr = m_pStockLevel->CallSetComplete();
        if (FAILED(hr))
            throw new CCOMERR(hr);

        hr = m_pOrderStatus->CallSetComplete();
        if (FAILED(hr))
            throw new CCOMERR(hr);
    }
}

CTPCC_COM::~CTPCC_COM()
{
    if (m_pTxn)
        SafeArrayDestroy(m_vTxn.parray);

    ReleaseInterface(m_pNewOrder);
    if (!m_bSinglePool)
    {
        ReleaseInterface(m_pPayment);
        ReleaseInterface(m_pStockLevel);
        ReleaseInterface(m_pOrderStatus);
    }
    CoUninitialize();
}

void CTPCC_COM::NewOrder()
{
    VARIANT vTxn_out;

    HRESULT hr = m_pNewOrder->NewOrder(m_vTxn, &vTxn_out);
    if (FAILED(hr))
        throw new CCOMERR( hr );

    memcpy(m_pTxn, (void *)vTxn_out.parray->pvData, vTxn_out.parray->rgsabound[0].cElements);
    SafeArrayDestroy(vTxn_out.parray);

    if ( m_pTxn->ErrorType != ERR_SUCCESS )
        throw new CCOMERR( m_pTxn->ErrorType, m_pTxn->error );
```

## Appendix A - Application Source Code

```
}
void CTPCC_COM::Payment()
{
    VARIANT vTxn_out;

    HRESULT hr = m_pPayment->Payment(m_vTxn, &vTxn_out);
    if (FAILED(hr))
        throw new CCOMERR( hr );
    memcpy(m_pTxn, (void *)vTxn_out.parray->pvData, vTxn_out.parray-
>rgsabound[0].cElements);
    SafeArrayDestroy(vTxn_out.parray);

    if ( m_pTxn->ErrorType != ERR_SUCCESS )
        throw new CCOMERR( m_pTxn->ErrorType, m_pTxn->error );
}

void CTPCC_COM::StockLevel()
{
    VARIANT vTxn_out;

    HRESULT hr = m_pStockLevel->StockLevel(m_vTxn, &vTxn_out);
    if (FAILED(hr))
        throw new CCOMERR( hr );
    memcpy(m_pTxn, (void *)vTxn_out.parray->pvData, vTxn_out.parray-
>rgsabound[0].cElements);
    SafeArrayDestroy(vTxn_out.parray);

    if ( m_pTxn->ErrorType != ERR_SUCCESS )
        throw new CCOMERR( m_pTxn->ErrorType, m_pTxn->error );
}

void CTPCC_COM::OrderStatus()
{
    VARIANT vTxn_out;

    HRESULT hr = m_pOrderStatus->OrderStatus(m_vTxn, &vTxn_out);
    if (FAILED(hr))
        throw new CCOMERR( hr );
    memcpy(m_pTxn, (void *)vTxn_out.parray->pvData, vTxn_out.parray-
>rgsabound[0].cElements);
    SafeArrayDestroy(vTxn_out.parray);

    if ( m_pTxn->ErrorType != ERR_SUCCESS )
        throw new CCOMERR( m_pTxn->ErrorType, m_pTxn->error );
}
```

### tm\_com\_dll/src/tpcc\_com.h

```
/* FILE: TPCC_COM.H
 * Microsoft TPC-C Kit Ver. 4.20.000
 * Copyright Microsoft, 1999
 * All Rights Reserved
 * not yet audited
 * PURPOSE: Header file for TPC-C COM+ class implementation.
 * Change history:
```

```
* 4.20.000 - first version
*/

#pragma once

#include <stdio.h>
#include "..\..\tpcc_com_ps\src\tpcc_com_ps.h"

// need to declare functions for import, unless define has already been created
// by the DLL's .cpp module for export.
#ifdef DllDecl
#define DllDecl __declspec( dllimport )
#endif

class CCOMERR : public CBaseErr
{
private:
    char m_szErrorText[64];

public:
    // use this interface for genuine COM errors
    CCOMERR( HRESULT hr )
    {
        m_hr = hr;
        m_iErrorType = 0;
        m_iError = 0;
    }

    // use this interface to impersonate a non-COM error type
    CCOMERR( int iErrorType, int iError )
    {
        m_iErrorType = iErrorType;
        m_iError = iError;
        m_hr = S_OK;
    }

    int m_hr;
    int m_iErrorType;
    int m_iError;

    // A CCOMERR class can impersonate another class, which happens if
the error // was not actually a COM Services error, but was simply transmitted
back via COM.

    int ErrorType()
    {
        if (m_iErrorType == 0)
            return ERR_TYPE_COM;
        else
            return m_iErrorType;
    }

    int ErrorNum() {return m_hr;}

    char *ErrorText()
    {
        if (m_hr == S_OK)
            sprintf( m_szErrorText, "Error: Class %d, error #
%d", m_iErrorType, m_iError );
        else
            sprintf( m_szErrorText, "Error: COM HRESULT %x",
m_hr );
        return m_szErrorText;
    }
};
```

## Appendix A - Application Source Code

```
};
}

class DllDecl CTPCC_COM : public CTPCC_BASE
{
private:
    BOOL m_bSinglePool;

    // COM Interface pointers
    ITPCC* m_pNewOrder;
    ITPCC* m_pPayment;
    ITPCC* m_pStockLevel;
    ITPCC* m_pOrderStatus;

    struct COM_DATA
    {
        int ErrorType;
        int error;
        union
        {
            NEW_ORDER_DATA NewOrder;
            PAYMENT_DATA Payment;
            DELIVERY_DATA Delivery;
            STOCK_LEVEL_DATA StockLevel;
            ORDER_STATUS_DATA OrderStatus;
        } u;
    } *m_pTxn;

public:
    VARIANT m_vTxn;

    CTPCC_COM(BOOL bSinglePool);
    ~CTPCC_COM(void);

    inline PNEW_ORDER_DATA BuffAddr_NewOrder();
    { return &m_pTxn->u.NewOrder; };
    inline PPAYMENT_DATA BuffAddr_Payment();
    { return &m_pTxn->u.Payment; };
    inline PDELIVERY_DATA BuffAddr_Delivery();
    { return &m_pTxn->u.Delivery; };
    inline PSTOCK_LEVEL_DATA BuffAddr_StockLevel() { return
&m_pTxn->u.StockLevel; };
    inline PORDER_STATUS_DATA BuffAddr_OrderStatus() { return
&m_pTxn->u.OrderStatus; };

    void NewOrder ();
    void Payment ();
    void StockLevel ();
    void OrderStatus ();
    void Delivery () { throw new CCOMERR(E_NOTIMPL); }

// not supported
};

inline void ReleaseInterface(IUnknown *pUnk)
{
    if (pUnk)
    {
        pUnk->Release();
        pUnk = NULL;
    }
}
}
```

```
// wrapper routine for class constructor
extern "C" __declspec(dllexport) CTPCC_COM* CTPCC_COM_new(BOOL);

typedef CTPCC_COM* (TYPE_CTPCC_COM)(BOOL);
```

### tpcc\_com\_all/src/methods.h

```
/* FILE: METHODS.H
 * Microsoft TPC-C Kit Ver. 4.20.000
 * Copyright Microsoft, 1999
 * All Rights Reserved
 *
 * not yet audited
 *
 * PURPOSE: Header file for COM components.
 *
 * Change history:
 * 4.20.000 - first version
 */
```

```
enum COMPONENT_ERROR
```

```
{
    ERR_MISSING_REGISTRY_ENTRIES = 1,
    ERR_LOADDLL_FAILED,
    ERR_GETPROCADDR_FAILED,
    ERR_UNKNOWN_DB_PROTOCOL
};
```

```
class CCOMPONENT_ERR : public CBaseErr
```

```
{
public:
    CCOMPONENT_ERR(COMPONENT_ERROR Err)
    {
        m_Error = Err;
        m_szTextDetail = NULL;
        m_SystemErr = 0;
        m_szErrorText = NULL;
    };

    CCOMPONENT_ERR(COMPONENT_ERROR Err, char
*szTextDetail, DWORD dwSystemErr)
    {
        m_Error = Err;
        m_szTextDetail = new
char[strlen(szTextDetail)+1];
```

## Appendix A - Application Source Code

```
        strcpy( m_szTextDetail, szTextDetail );
        m_SystemErr = dwSystemErr;
        m_szErrorText = NULL;
    };

~CCOMPONENT_ERR()
{
    if (m_szTextDetail != NULL)
        delete [] m_szTextDetail;
    if (m_szErrorText != NULL)
        delete [] m_szErrorText;
};

COMPONENT_ERROR    m_Error;
char                *m_szTextDetail;
char                *m_szErrorText;
DWORD              m_SystemErr;

int ErrorType() {return ERR_TYPE_COMPONENT;};
int ErrorNum() {return m_Error;};
char *ErrorText();
};

static void WriteMessageToEventLog(LPTSTR lpszMsg);

//////////////////////////////////////
//////////////////////////////////////
// CTPCC_Common
class CTPCC_Common :
    public ITPCC,
    public IObjectControl,
    public IObjectConstruct,
    public CComObjectRootEx<CComSingleThreadModel>
{
public:
    BEGIN_COM_MAP(CTPCC_Common)
        COM_INTERFACE_ENTRY(ITPCC)
        COM_INTERFACE_ENTRY(IObjectControl)
        COM_INTERFACE_ENTRY(IObjectConstruct)
    END_COM_MAP()

    CTPCC_Common();
    ~CTPCC_Common();

// ITPCC

public:
    HRESULT __stdcall NewOrder(          VARIANT txn_in,
    VARIANT* txn_out);
    HRESULT __stdcall Payment(          VARIANT txn_in,
    VARIANT* txn_out);
    HRESULT __stdcall Delivery(         VARIANT txn_in,
    VARIANT* txn_out) {return E_NOTIMPL;};
    HRESULT __stdcall StockLevel(VARIANT txn_in, VARIANT*
    txn_out);
    HRESULT __stdcall OrderStatus(      VARIANT txn_in,
    VARIANT* txn_out);

    HRESULT __stdcall CallSetComplete();

// IObjectControl
    STDMETHODCALLTYPE CanBePooled() { return m_bCanBePooled;
}
    STDMETHODCALLTYPE Activate() { return S_OK; } // we don't
support COM Services transactions (no enlistment)
    STDMETHODCALLTYPE Deactivate() { /* nothing to do */ }

// IObjectConstruct
    STDMETHODCALLTYPE Construct(IDispatch * pUnk);

// helper methods
private:
    BOOL                m_bCanBePooled;
    CTPCC_BASE         *m_pTxn;

    struct COM_DATA
    {
        int retval;
        int error;
        union
        {
            NEW_ORDER_DATA        NewOrder;
            PAYMENT_DATA           Payment;
            DELIVERY_DATA          Delivery;
            STOCK_LEVEL_DATA       StockLevel;
            ORDER_STATUS_DATA      OrderStatus;
        } u;
    };
};

//////////////////////////////////////
//////////////////////////////////////
```

## Appendix A - Application Source Code

```
// CTPCC
class CTPCC :
    public CTPCC_Common,
    public CComCoClass<CTPCC, &CLSID_TPCC>
{
public:
DECLARE_REGISTRY_RESOURCEID(IDR_TPCC)

BEGIN_COM_MAP(CTPCC)
    COM_INTERFACE_ENTRY2(IUnknown, CComObjectRootEx)
    COM_INTERFACE_ENTRY_CHAIN(CTPCC_Common)
END_COM_MAP()

};

////////////////////////////////////
////////////////////////////////////
// CNewOrder
class CNewOrder :
    public CTPCC_Common,
    public CComCoClass<CNewOrder, &CLSID_NewOrder>
{
public:
DECLARE_REGISTRY_RESOURCEID(IDR_NEWORDER)

BEGIN_COM_MAP(CNewOrder)
    COM_INTERFACE_ENTRY2(IUnknown, CComObjectRootEx)
    COM_INTERFACE_ENTRY_CHAIN(CTPCC_Common)
END_COM_MAP()

// ITPCC
public:
// HRESULT __stdcall NewOrder(          VARIANT txn_in,
VARIANT* txn_out) {return E_NOTIMPL;}
    HRESULT __stdcall Payment(          VARIANT txn_in,
VARIANT* txn_out) {return E_NOTIMPL;}
    HRESULT __stdcall StockLevel(VARIANT txn_in, VARIANT*
txn_out) {return E_NOTIMPL;}
    HRESULT __stdcall OrderStatus(      VARIANT txn_in,
VARIANT* txn_out) {return E_NOTIMPL;}
};

////////////////////////////////////
////////////////////////////////////
// COrderStatus
```

```
class COrderStatus :
    public CTPCC_Common,
    public CComCoClass<COrderStatus, &CLSID_OrderStatus>
{
public:
DECLARE_REGISTRY_RESOURCEID(IDR_ORDERSTATUS)

BEGIN_COM_MAP(COrderStatus)
    COM_INTERFACE_ENTRY2(IUnknown, CComObjectRootEx)
    COM_INTERFACE_ENTRY_CHAIN(CTPCC_Common)
END_COM_MAP()

// ITPCC
public:
    HRESULT __stdcall NewOrder(          VARIANT txn_in,
VARIANT* txn_out) {return E_NOTIMPL;}
    HRESULT __stdcall Payment(          VARIANT txn_in,
VARIANT* txn_out) {return E_NOTIMPL;}
    HRESULT __stdcall StockLevel(VARIANT txn_in, VARIANT*
txn_out) {return E_NOTIMPL;}
    // HRESULT __stdcall OrderStatus(      VARIANT txn_in,
VARIANT* txn_out) {return E_NOTIMPL;}
};

////////////////////////////////////
////////////////////////////////////
// CPayment
class CPayment :
    public CTPCC_Common,
    public CComCoClass<CPayment, &CLSID_Payment>
{
public:
DECLARE_REGISTRY_RESOURCEID(IDR_PAYMENT)

BEGIN_COM_MAP(CPayment)
    COM_INTERFACE_ENTRY2(IUnknown, CComObjectRootEx)
    COM_INTERFACE_ENTRY_CHAIN(CTPCC_Common)
END_COM_MAP()

// ITPCC
public:
    HRESULT __stdcall NewOrder(          VARIANT txn_in,
VARIANT* txn_out) {return E_NOTIMPL;}
    // HRESULT __stdcall Payment(          VARIANT txn_in,
VARIANT* txn_out) {return E_NOTIMPL;}
};
```

## Appendix A - Application Source Code

```
        HRESULT __stdcall StockLevel(VARIANT txn_in, VARIANT*
txn_out) {return E_NOTIMPL;}
        HRESULT __stdcall OrderStatus(        VARIANT txn_in,
VARIANT* txn_out) {return E_NOTIMPL;}
};
```

```
////////////////////////////////////
```

```
////////////////////////////////////
// CStockLevel
class CStockLevel :
    public CTPCC_Common,
    public CComCoClass<CStockLevel, &CLSID_StockLevel>
{
public:
DECLARE_REGISTRY_RESOURCEID(IDR_STOCKLEVEL)

BEGIN_COM_MAP(CStockLevel)
    COM_INTERFACE_ENTRY2(IUnknown, CComObjectRootEx)
    COM_INTERFACE_ENTRY_CHAIN(CTPCC_Common)
END_COM_MAP()

// ITPCC
public:
    HRESULT __stdcall NewOrder(        VARIANT txn_in,
VARIANT* txn_out) {return E_NOTIMPL;}
    HRESULT __stdcall Payment(        VARIANT txn_in,
VARIANT* txn_out) {return E_NOTIMPL;}
//    HRESULT __stdcall StockLevel(VARIANT txn_in, VARIANT*
txn_out) {return E_NOTIMPL;}
    HRESULT __stdcall OrderStatus(        VARIANT txn_in,
VARIANT* txn_out) {return E_NOTIMPL;}
};
```

### tpcc\_com\_all/src/resource.h

```
//{{NO_DEPENDENCIES}}
// Microsoft Developer Studio generated include file.
// Used by tpcc_com_all.rc
//
#define IDS_PROJNAME        100
#define IDR_TPCC            101
#define IDR_NEWORDER        102
#define IDR_ORDERSTATUS        103
#define IDR_PAYMENT        104
#define IDR_STOCKLEVEL        105
```

```
// Next default values for new objects
//
#ifdef APSTUDIO_INVOKED
#ifdef APSTUDIO_READONLY_SYMBOLS
#define _APS_NEXT_RESOURCE_VALUE        202
#define _APS_NEXT_COMMAND_VALUE        32768
#define _APS_NEXT_CONTROL_VALUE        201
#define _APS_NEXT_SYMED_VALUE        106
#endif
#endif
```

### tpcc\_com\_all/src/tpcc\_com\_all.cpp

```
/*      FILE:                TPC_C_COM_ALL.CPP
 *
 *      Microsoft TPC-C Kit Ver. 4.20.000
 *      Copyright Microsoft, 1999
 *
 *      All Rights Reserved
 *
 *      Version 4.10.000 audited by Richard Gimarc,
 *      Performance Metrics, 3/17/99
 *
 *      PURPOSE: Implementation for TPC-C Tuxedo class.
 *      Contact: Charles Levine (clevine@microsoft.com)
 *
 *      Change history:
 *      4.20.000 - updated rev number to match kit
 */

#define STRICT
#define _WIN32_WINNT 0x0400
#define _ATL_APARTMENT_THREADED

#include <stdio.h>
#include <atlbase.h>
//You may derive a class from CComModule and use it if you want to override
//something, but do not change the name of _Module
extern CComModule _Module;

#include <atlcom.h>
#include <initguid.h>
#include <transact.h>
#include <atlimpl.cpp>
#include <comsvcs.h>

#include <sqltypes.h>
#include <sql.h>
#include <sqlext.h>

#include "tpcc_com_ps.h"
#include "..\..\common\src\trans.h" //tpckit
transaction header contains definations of structures specific to TPC-C
#include "..\..\common\src\txn_base.h"
#include "..\..\common\src\error.h"
#include "..\..\common\src\ReadRegistry.h"
#include "..\..\db_dblib_dll\src\tpcc_dblib.h" // DBLIB implementation of
TPC-C txns
#include "..\..\db_odbc_dll\src\tpcc_odbc.h" // ODBC implementation of
TPC-C txns
```

## Appendix A - Application Source Code

```
#include "resource.h"
#include "tpcc_com_all.h"
#include "tpcc_com_all_i.c"
#include "Methods.h"
#include "..\..\tpcc_com_ps\src\tpcc_com_ps_i.c"
#include "..\..\common\src\ReadRegistry.cpp"

CComModule _Module;

BEGIN_OBJECT_MAP(ObjectMap)
    OBJECT_ENTRY(CLSID_TPCC, CTPCC)
    OBJECT_ENTRY(CLSID_NewOrder, CNewOrder)
    OBJECT_ENTRY(CLSID_OrderStatus, COrderStatus)
    OBJECT_ENTRY(CLSID_Payment, CPayment)
    OBJECT_ENTRY(CLSID_StockLevel, CStockLevel)
END_OBJECT_MAP()

// configuration settings from registry
TPCCREGISTRYDATA Reg;
char szMyComputerName[MAX_COMPUTERNAME_LENGTH+1];

static HINSTANCE hLibInstanceDb = NULL;

TYPE_CTPCC_DBLIB *pCTPCC_DBLIB_new;
TYPE_CTPCC_ODBC *pCTPCC_ODBC_new;

////////////////////////////////////
// DLL Entry Point

extern "C"
BOOL WINAPI DllMain(HINSTANCE hInstance, DWORD dwReason, LPVOID /*lpReserved*/)
{
    char szDllName[128];

    try
    {
        if (dwReason == DLL_PROCESS_ATTACH)
        {
            _Module.Init(ObjectMap, hInstance);
            DisableThreadLibraryCalls(hInstance);

            DWORD dwSize = MAX_COMPUTERNAME_LENGTH+1;
            GetComputerName(szMyComputerName, &dwSize);
            szMyComputerName[dwSize] = 0;

            if ( ReadTPCCRegistrySettings( &Reg ) )
                throw new CCOMPONENT_ERR(
ERR_MISSING_REGISTRY_ENTRIES );

            if (Reg.eDB_Protocol == DBLIB)
            {
                strcpy( szDllName, Reg.szPath );
                strcat( szDllName, "tpcc_dblib.dll");
                hLibInstanceDb = LoadLibrary( szDllName );
                if (hLibInstanceDb == NULL)
                    throw new CCOMPONENT_ERR(
ERR_LOADDLL_FAILED, szDllName, GetLastError() );
            }

            // get function pointer to wrapper for class
            constructor

```

```
                pCTPCC_DBLIB_new = (TYPE_CTPCC_DBLIB*)
GetProcAddress(hLibInstanceDb, "CTPCC_DBLIB_new");
                if (pCTPCC_DBLIB_new == NULL)
                    throw new CCOMPONENT_ERR(
ERR_GETPROCADDR_FAILED, szDllName, GetLastError() );
            }
            else if (Reg.eDB_Protocol == ODBC)
            {
                strcpy( szDllName, Reg.szPath );
                strcat( szDllName, "tpcc_odbc.dll");
                hLibInstanceDb = LoadLibrary( szDllName );
                if (hLibInstanceDb == NULL)
                    throw new CCOMPONENT_ERR(
ERR_LOADDLL_FAILED, szDllName, GetLastError() );

                // get function pointer to wrapper for class
                constructor
                pCTPCC_ODBC_new = (TYPE_CTPCC_ODBC*)
GetProcAddress(hLibInstanceDb, "CTPCC_ODBC_new");
                if (pCTPCC_ODBC_new == NULL)
                    throw new CCOMPONENT_ERR(
ERR_GETPROCADDR_FAILED, szDllName, GetLastError() );
            }
            else
                throw new CCOMPONENT_ERR( ERR_UNKNOWN_DB_PROTOCOL

);

        }
        else if (dwReason == DLL_PROCESS_DETACH)
            _Module.Term();
    }
    catch (CBaseErr *e)
    {
        WriteMessageToEventLog(e->ErrorText());
        delete e;
        return FALSE;
    }
    catch (...)
    {
        WriteMessageToEventLog(TEXT("Unhandled exception in object
DllMain"));
        return FALSE;
    }

    return TRUE; // OK
}

////////////////////////////////////
// Used to determine whether the DLL can be unloaded by OLE

STDAPI DllCanUnloadNow(void)
{
    return (_Module.GetLockCount()==0) ? S_OK : S_FALSE;
}

////////////////////////////////////
// Returns a class factory to create an object of the requested type

STDAPI DllGetClassObject(REFCLSID rclsid, REFIID riid, LPVOID* ppv)
{
    return _Module.GetClassObject(rclsid, riid, ppv);
}
```

## Appendix A - Application Source Code

```
////////////////////////////////////
// DllRegisterServer - Adds entries to the system registry

STDAPI DllRegisterServer(void)
{
    // registers object, typelib and all interfaces in typelib
    return _Module.RegisterServer(TRUE);
}

////////////////////////////////////
// DllUnregisterServer - Removes entries from the system registry

STDAPI DllUnregisterServer(void)
{
    _Module.UnregisterServer();
    return S_OK;
}

static void WriteMessageToEventLog(LPTSTR lpszMsg)
{
    TCHAR    szMsg[256];
    HANDLE   hEventSource;
    LPTSTR   lpszStrings[2];

    // Use event logging to log the error.
    //
    hEventSource = RegisterEventSource(NULL, TEXT("tpcc_com_all.dll"));

    _stprintf(szMsg, TEXT("Error in COM+ TPC-C Component: "));
    lpszStrings[0] = szMsg;
    lpszStrings[1] = lpszMsg;

    if (hEventSource != NULL)
    {
        ReportEvent(hEventSource, // handle of event source
            EVENTLOG_ERROR_TYPE, // event type
            0, // event category
            0, // event ID
            NULL, // current user's SID
            2, // strings in lpszStrings
            0, // no bytes of raw data
            (LPTSTR *)lpszStrings, // array of error strings
            NULL); // no raw data

        (VOID) DeregisterEventSource(hEventSource);
    }
}

inline void ReleaseInterface(IUnknown *pUnk)
{
    if (pUnk)
    {
        pUnk->Release();
        pUnk = NULL;
    }
}

/* FUNCTION: CCOMPONENT_ERR::ErrorText
 *
 */

char* CCOMPONENT_ERR::ErrorText(void)
```

```
{
    static SERRORMSG errorMsgs[] =
    {
        { ERR_MISSING_REGISTRY_ENTRIES, "Required entries missing
from registry." },
        { ERR_LOADDLL_FAILED, "Load of DLL
failed. DLL=" },
        { ERR_GETPROCADDR_FAILED, "Could not map proc in DLL.
GetProcAddr error. DLL=" },
        { ERR_UNKNOWN_DB_PROTOCOL, "Unknown database protocol
specified in registry." },
        { 0, "" }
    };

    char szTmp[256];
    int i = 0;
    while (TRUE)
    {
        if (errorMsgs[i].szMsg[0] == 0)
        {
            strcpy( szTmp, "Unknown error number. " );
            break;
        }
        if (m_Error == errorMsgs[i].iError)
        {
            strcpy( szTmp, errorMsgs[i].szMsg );
            break;
        }
        i++;
    }

    if (m_szTextDetail)
        strcat( szTmp, m_szTextDetail );
    if (m_SystemErr)
        wsprintf( szTmp+strlen(szTmp), " Error=%d", m_SystemErr );

    m_szErrorText = new char[strlen(szTmp)+1];
    strcpy( m_szErrorText, szTmp );
    return m_szErrorText;
}

CTPCC_Common::CTPCC_Common()
{
    m_pTxn = NULL;
    m_bCanBePooled = TRUE;
}

CTPCC_Common::~CTPCC_Common()
{
    if (m_pTxn)
        delete m_pTxn;
}

HRESULT CTPCC_Common::CallSetComplete()
{
    IObjectContext* pObjectContext = NULL;

    // get our object context
```

## Appendix A - Application Source Code

```
HRESULT hr = CoGetObjectContext( IID_IObjectContext, (void **)&pObjectContext
);
pObjectContext->SetComplete();
ReleaseInterface(pObjectContext);
return hr;
}
//
// called by the ctor activator
//
STDMETHODIMP CTPCC_Common::Construct(IDispatch * pUnk)
{
    // Code to access construction string, if needed later...
    // if (!pUnk)
    //     return E_UNEXPECTED;
    // IObjectConstructString * pString = NULL;
    // HRESULT hr = pUnk->QueryInterface(IID_IObjectConstructString, (void
**)&pString);
    // pString->Release();

    try
    {
        if (Reg.eDB_Protocol == ODBC)
            m_pTxn = pCTPCC_ODBC_new( Reg.szDbServer, Reg.szDbUser,
Reg.szDbPassword, szMyComputerName, Reg.szDbName );
        else if (Reg.eDB_Protocol == DBLIB)
            m_pTxn = pCTPCC_DBLIB_new( Reg.szDbServer, Reg.szDbUser,
Reg.szDbPassword, szMyComputerName, Reg.szDbName );
    }
    catch (CBaseErr *e)
    {
        WriteMessageToEventLog(e->ErrorText());
        delete e;
        return E_FAIL;
    }
    catch (...)
    {
        WriteMessageToEventLog(TEXT("Unhandled exception in object
::Construct"));
        return E_FAIL;
    }

    return S_OK;
}

HRESULT CTPCC_Common::NewOrder(VARIANT txn_in, VARIANT* txn_out)
{
    PNEW_ORDER_DATA    pNewOrder;
    COM_DATA           *pData;
    try
    {
        pData = (COM_DATA*)txn_in.parray->pvData;
        pNewOrder = m_pTxn->BuffAddr_NewOrder();

        memcpy(pNewOrder, &pData->u.NewOrder, sizeof(NEW_ORDER_DATA));

        m_pTxn->NewOrder();           // do the actual txn

        VariantInit(txn_out);
        txn_out->vt = VT_SAFEARRAY;
        txn_out->parray = SafeArrayCreateVector(VT_UI1,
txn_in.parray-
>rgsabound->cElements,
txn_in.parray-
```

```
txn_in.parray-
>rgsabound->cElements);
        pData = (COM_DATA*) txn_out->parray->pvData;

        memcpy( &pData->u.NewOrder, pNewOrder, sizeof(NEW_ORDER_DATA));

        pData->retval = ERR_SUCCESS;
        pData->error = 0;
        return S_OK;
    }
    catch (CBaseErr *e)
    {
        // check for lost database connection; if yes, component is toast
        if ( ((e->ErrorType() == ERR_TYPE_DBLIB) && (e->ErrorNum() == 10005))
||
10054)) )
            ((e->ErrorType() == ERR_TYPE_ODBC) && (e->ErrorNum() ==
m_bCanBePooled = FALSE;

        pData->retval = e->ErrorType();
        pData->error = e->ErrorNum();
        delete e;
        return E_FAIL;
    }
    catch (...)
    {
        WriteMessageToEventLog(TEXT("Unhandled exception.));
        pData->retval = ERR_TYPE_LOGIC;
        pData->error = 0;
        m_bCanBePooled = FALSE;
        return E_FAIL;
    }
}

HRESULT CTPCC_Common::Payment(VARIANT txn_in, VARIANT* txn_out)
{
    PPAYMENT_DATA      pPayment;
    COM_DATA           *pData;
    try
    {
        pData = (COM_DATA*)txn_in.parray->pvData;
        pPayment = m_pTxn->BuffAddr_Payment();

        memcpy(pPayment, &pData->u.Payment, sizeof(PAYMENT_DATA));

        m_pTxn->Payment();           // do the actual txn

        VariantInit(txn_out);
        txn_out->vt = VT_SAFEARRAY;
        txn_out->parray = SafeArrayCreateVector( VT_UI1,
txn_in.parray-
>rgsabound->cElements,
txn_in.parray-
>rgsabound->cElements);
        pData = (COM_DATA*) txn_out->parray->pvData;

        memcpy( &pData->u.Payment, pPayment, sizeof(PAYMENT_DATA));

        pData->retval = ERR_SUCCESS;
        pData->error = 0;
        return S_OK;
    }
    catch (CBaseErr *e)
```

## Appendix A - Application Source Code

```
{
    // check for lost database connection; if yes, component is toast
    if ( ((e->ErrorType() == ERR_TYPE_DBLIB) && (e->ErrorNum() == 10005))
||
10054)) )
        ((e->ErrorType() == ERR_TYPE_ODBC) && (e->ErrorNum() ==
            m_bCanBePooled = FALSE;

        pData->retval = e->ErrorType();
        pData->error = e->ErrorNum();
        delete e;
        return E_FAIL;
    }
    catch (...)
    {
        WriteMessageToEventLog(TEXT("Unhandled exception.));
        pData->retval = ERR_TYPE_LOGIC;
        pData->error = 0;
        m_bCanBePooled = FALSE;
        return E_FAIL;
    }
}

HRESULT CTPCC_Common::StockLevel(VARIANT txn_in, VARIANT* txn_out)
{
    PSTOCK_LEVEL_DATA pStockLevel;
    COM_DATA          *pData;

    try
    {
        pData = (COM_DATA*)txn_in.parray->pvData;
        pStockLevel = m_pTxn->BuffAddr_StockLevel();

        memcpy(pStockLevel, &pData->u.StockLevel, sizeof(STOCK_LEVEL_DATA));
        m_pTxn->StockLevel();

        VariantInit(txn_out);
        txn_out->vt = VT_SAFEARRAY;
        txn_out->parray = SafeArrayCreateVector( VT_UI1,
            txn_in.parray-
>rgsabound->cElements,
            txn_in.parray-
>rgsabound->cElements);
        pData = (COM_DATA*)txn_out->parray->pvData;

        memcpy( &pData->u.StockLevel, pStockLevel, sizeof(STOCK_LEVEL_DATA));

        pData->retval = ERR_SUCCESS;
        pData->error = 0;
        return S_OK;
    }
    catch (CBaseErr *e)
    {
        // check for lost database connection; if yes, component is toast
        if ( ((e->ErrorType() == ERR_TYPE_DBLIB) && (e->ErrorNum() == 10005))
||
10054)) )
            ((e->ErrorType() == ERR_TYPE_ODBC) && (e->ErrorNum() ==
                m_bCanBePooled = FALSE;

                pData->retval = e->ErrorType();
                pData->error = e->ErrorNum();
                delete e;
                return E_FAIL;
            }
        catch (...)
        {
            WriteMessageToEventLog(TEXT("Unhandled exception.));
            pData->retval = ERR_TYPE_LOGIC;
            pData->error = 0;
            m_bCanBePooled = FALSE;
        }
    }
}
```

```
        delete e;
        return E_FAIL;
    }
    catch (...)
    {
        WriteMessageToEventLog(TEXT("Unhandled exception.));
        pData->retval = ERR_TYPE_LOGIC;
        pData->error = 0;
        m_bCanBePooled = FALSE;
        return E_FAIL;
    }
}

HRESULT CTPCC_Common::OrderStatus(VARIANT txn_in, VARIANT* txn_out)
{
    PORDER_STATUS_DATA pOrderStatus;
    COM_DATA          *pData;
    try
    {
        pData = (COM_DATA*)txn_in.parray->pvData;
        pOrderStatus = m_pTxn->BuffAddr_OrderStatus();

        memcpy(pOrderStatus, &pData->u.OrderStatus,
            sizeof(ORDER_STATUS_DATA));

        m_pTxn->OrderStatus();

        VariantInit(txn_out);
        txn_out->vt = VT_SAFEARRAY;
        txn_out->parray = SafeArrayCreateVector( VT_UI1,
            txn_in.parray-
>rgsabound->cElements,
            txn_in.parray-
>rgsabound->cElements);
        pData = (COM_DATA*)txn_out->parray->pvData;

        memcpy( &pData->u.OrderStatus, pOrderStatus,
            sizeof(ORDER_STATUS_DATA));

        pData->retval = ERR_SUCCESS;
        pData->error = 0;
        return S_OK;
    }
    catch (CBaseErr *e)
    {
        // check for lost database connection; if yes, component is toast
        if ( ((e->ErrorType() == ERR_TYPE_DBLIB) && (e->ErrorNum() == 10005))
||
10054)) )
            ((e->ErrorType() == ERR_TYPE_ODBC) && (e->ErrorNum() ==
                m_bCanBePooled = FALSE;

                pData->retval = e->ErrorType();
                pData->error = e->ErrorNum();
                delete e;
                return E_FAIL;
            }
        catch (...)
        {
            WriteMessageToEventLog(TEXT("Unhandled exception.));
            pData->retval = ERR_TYPE_LOGIC;
            pData->error = 0;
            m_bCanBePooled = FALSE;
        }
    }
}
```

# Appendix A - Application Source Code

```
        return E_FAIL;
    }
}
```

## tpcc\_com\_all/src/tpcc\_com\_all.def

```
; tpcc_com_all.def : Declares the module parameters.
```

```
LIBRARY      "tpcc_com_all.dll"

EXPORTS
    DllCanUnloadNow      @1 PRIVATE
    DllGetClassObject    @2 PRIVATE
    DllRegisterServer    @3 PRIVATE
    DllUnregisterServer  @4 PRIVATE
```

## tpcc\_com\_all/src/tpcc\_com\_all.h

```
#pragma warning( disable: 4049 ) /* more than 64k source lines */

/* this ALWAYS GENERATED file contains the definitions for the interfaces */

/* File created by MIDL compiler version 5.03.0280 */
/* at Sat Apr 08 16:40:18 2000 */
/*
 * Compiler settings for .\src\tpcc_com_all.idl:
 *   Oicf (OptLev=12), W1, Zp8, env=Win32 (32b run), ms_ext, c_ext
 *   error checks: allocation ref bounds_check enum stub_data
 *   VC __declspec() decoration level:
 *     __declspec(uuid()), __declspec(selectany), __declspec(novtable)
 *     DECLSPEC_UUID(), MIDL_INTERFACE()
 */
//@@MIDL_FILE_HEADING(  )

/* verify that the <rpcndr.h> version is high enough to compile this file*/
#ifndef __REQUIRED_RPCNDR_H_VERSION__
#define __REQUIRED_RPCNDR_H_VERSION__ 440
#endif

#include "rpc.h"
#include "rpcndr.h"

#ifndef __tpcc_com_all_h__
#define __tpcc_com_all_h__

/* Forward Declarations */

#ifndef __TPCC_FWD_DEFINED__
#define __TPCC_FWD_DEFINED__
```

```
#ifndef __cplusplus
typedef class TPCC TPCC;
#else
typedef struct TPCC TPCC;
#endif /* __cplusplus */

#endif /* __TPCC_FWD_DEFINED__ */

#ifndef __NewOrder_FWD_DEFINED__
#define __NewOrder_FWD_DEFINED__

#ifdef __cplusplus
typedef class NewOrder NewOrder;
#else
typedef struct NewOrder NewOrder;
#endif /* __cplusplus */

#endif /* __NewOrder_FWD_DEFINED__ */

#ifndef __OrderStatus_FWD_DEFINED__
#define __OrderStatus_FWD_DEFINED__

#ifdef __cplusplus
typedef class OrderStatus OrderStatus;
#else
typedef struct OrderStatus OrderStatus;
#endif /* __cplusplus */

#endif /* __OrderStatus_FWD_DEFINED__ */

#ifndef __Payment_FWD_DEFINED__
#define __Payment_FWD_DEFINED__

#ifdef __cplusplus
typedef class Payment Payment;
#else
typedef struct Payment Payment;
#endif /* __cplusplus */

#endif /* __Payment_FWD_DEFINED__ */

#ifndef __StockLevel_FWD_DEFINED__
#define __StockLevel_FWD_DEFINED__

#ifdef __cplusplus
typedef class StockLevel StockLevel;
#else
typedef struct StockLevel StockLevel;
#endif /* __cplusplus */

#endif /* __StockLevel_FWD_DEFINED__ */

/* header files for imported files */
#include "oaidl.h"
#include "ocidl.h"
#include "tpcc_com_ps.h"

#ifdef __cplusplus
```

## Appendix A - Application Source Code

```
extern "C"{
#endif

void __RPC_FAR * __RPC_USER MIDL_user_allocate(size_t);
void __RPC_USER MIDL_user_free( void __RPC_FAR * );

/* interface __MIDL_itf_tpcc_com_all_0000 */
/* [local] */

extern RPC_IF_HANDLE __MIDL_itf_tpcc_com_all_0000_v0_0_c_ifspec;
extern RPC_IF_HANDLE __MIDL_itf_tpcc_com_all_0000_v0_0_s_ifspec;

#ifdef __TPCCLib_LIBRARY_DEFINED__
#define __TPCCLib_LIBRARY_DEFINED__

/* library TPCCLib */
/* [helpstring][version][uuid] */

EXTERN_C const IID LIBID_TPCCLib;

EXTERN_C const CLSID CLSID_TPCC;

#ifdef __cplusplus

class DECLSPEC_UUID("122A3128-2520-11D3-BA71-00C04FBFE08B")
TPCC;
#endif

EXTERN_C const CLSID CLSID_NewOrder;

#ifdef __cplusplus

class DECLSPEC_UUID("975BAABF-84A7-11D2-BA47-00C04FBFE08B")
NewOrder;
#endif

EXTERN_C const CLSID CLSID_OrderStatus;

#ifdef __cplusplus

class DECLSPEC_UUID("266836AD-A50D-11D2-BA4E-00C04FBFE08B")
OrderStatus;
#endif

EXTERN_C const CLSID CLSID_Payment;

#ifdef __cplusplus

class DECLSPEC_UUID("CD02F7EF-A4FA-11D2-BA4E-00C04FBFE08B")
Payment;
#endif

EXTERN_C const CLSID CLSID_StockLevel;
```

```
#ifdef __cplusplus

class DECLSPEC_UUID("2668369E-A50D-11D2-BA4E-00C04FBFE08B")
StockLevel;
#endif /* __TPCCLib_LIBRARY_DEFINED__ */

/* Additional Prototypes for ALL interfaces */

/* end of Additional Prototypes */

#ifdef __cplusplus
}
#endif

#endif
```

### tpcc\_com\_all/src/tpcc\_com\_all.idl

```
/* FILE: TPCC.IDL
 * Microsoft TPC-C Kit Ver. 4.20.000
 * Copyright Microsoft, 1999
 * All Rights Reserved
 * not yet audited
 * PURPOSE: IDL source for TPCC.dll. This file is processed by the MIDL tool to
 * produce the type library (TPCC.tlb) and
 * marshalling code.
 * Change history:
 * 4.20.000 - first version
 */

interface TPCC;
interface NewOrder;
interface OrderStatus;
interface Payment;
interface StockLevel;

import "oaidl.idl";
import "ocidl.idl";
import "..\tpcc_com_ps\src\tpcc_com_ps.idl";

[
    uuid(122A3117-2520-11D3-BA71-00C04FBFE08B),
    version(1.0),
    helpstring("TPC-C 1.0 Type Library")
]
library TPCCLib
{
    importlib("stdole32.tlb");
    importlib("stdole2.tlb");

    [
        uuid(122A3128-2520-11D3-BA71-00C04FBFE08B),
```

# Appendix A - Application Source Code

```
        helpstring("All Txns Class")
    }
    coclass TPCC
    {
        [default] interface ITPCC;
    };

    [
        uuid(975BAABF-84A7-11D2-BA47-00C04FBFE08B),
        helpstring("NewOrder Class")
    ]
    coclass NewOrder
    {
        [default] interface ITPCC;
    };

    [
        uuid(266836AD-A50D-11D2-BA4E-00C04FBFE08B),
        helpstring("OrderStatus Class")
    ]
    coclass OrderStatus
    {
        [default] interface ITPCC;
    };

    [
        uuid(CD02F7EF-A4FA-11D2-BA4E-00C04FBFE08B),
        helpstring("Payment Class")
    ]
    coclass Payment
    {
        [default] interface ITPCC;
    };

    [
        uuid(2668369E-A50D-11D2-BA4E-00C04FBFE08B),
        helpstring("StockLevel Class")
    ]
    coclass StockLevel
    {
        [default] interface ITPCC;
    };
};
```

tpcc\_com\_all/src/tpcc\_com\_all.rc

```
//Microsoft Developer Studio generated resource script.
//
#include "resource.h"

#define APSTUDIO_READONLY_SYMBOLS
////////////////////////////////////
//
// Generated from the TEXTINCLUDE 2 resource.
```

```
//
#include "winres.h"

////////////////////////////////////
#undef APSTUDIO_READONLY_SYMBOLS

////////////////////////////////////
// English (U.S.) resources

#if !defined(AFX_RESOURCE_DLL) || defined(AFX_TARG_ENU)
#ifdef _WIN32
LANGUAGE LANG_ENGLISH, SUBLANG_ENGLISH_US
#pragma code_page(1252)
#endif // _WIN32

#ifdef APSTUDIO_INVOKED
////////////////////////////////////
//
// TEXTINCLUDE
//

1 TEXTINCLUDE DISCARDABLE
BEGIN
    "resource.h\0"
END

2 TEXTINCLUDE DISCARDABLE
BEGIN
    "#include \"winres.h\"\r\n"
    "\0"
END

3 TEXTINCLUDE DISCARDABLE
BEGIN
    "1 TYPELIB \"tpcc_com_all.tlb\"\r\n"
    "\0"
END

#endif // APSTUDIO_INVOKED

#ifdef _MAC
////////////////////////////////////
//
// Version
//

VS_VERSION_INFO VERSIONINFO
FILEVERSION 1,0,0,1
PRODUCTVERSION 1,0,0,1
FILEFLAGSMASK 0x3fL
#ifdef _DEBUG
FILEFLAGS 0x1L
#else
FILEFLAGS 0x0L
#endif
FILEOS 0x4L
FILETYPE 0x2L
FILESUBTYPE 0x0L
BEGIN
    BLOCK "StringFileInfo"
    BEGIN
        BLOCK "040904B0"
```

## Appendix A - Application Source Code

```
BEGIN
    VALUE "CompanyName", "\0"
    VALUE "FileDescription", "tpcc_com_all Module\0"
    VALUE "FileVersion", "1, 0, 0, 1\0"
    VALUE "InternalName", "TPCCNEWORDER\0"
    VALUE "LegalCopyright", "Copyright 1997\0"
    VALUE "OriginalFilename", "tpcc_com_all.DLL\0"
    VALUE "ProductName", "tpcc_com_all Module\0"
    VALUE "ProductVersion", "1, 0, 0, 1\0"
    VALUE "OLESelfRegister", "\0"
END
END
BLOCK "VarFileInfo"
BEGIN
    VALUE "Translation", 0x409, 1200
END
END

#endif // !_MAC

////////////////////////////////////
//
// REGISTRY
//
IDR_TPCC           REGISTRY DISCARDABLE "tpcc_com_all.rgs"
IDR_NEWORDER      REGISTRY DISCARDABLE "tpcc_com_no.rgs"
IDR_ORDERSTATUS   REGISTRY DISCARDABLE "tpcc_com_os.rgs"
IDR_PAYMENT       REGISTRY DISCARDABLE "tpcc_com_pay.rgs"
IDR_STOCKLEVEL    REGISTRY DISCARDABLE "tpcc_com_sl.rgs"

////////////////////////////////////
//
// String Table
//
STRINGTABLE DISCARDABLE
BEGIN
    IDS_PROJNAME        "tpcc_com_all"
END

#endif // English (U.S.) resources
////////////////////////////////////

#ifndef APSTUDIO_INVOKED
////////////////////////////////////
//
// Generated from the TEXTINCLUDE 3 resource.
//
1 TYPELIB "tpcc_com_all.tlb"

////////////////////////////////////
#endif // not APSTUDIO_INVOKED
```

### tpcc\_com\_all/src/tpcc\_com\_all.rgs

```
HKCR
{
    TPCC.AllTxns.1 = s 'All Txns Class'
    {
        CLSID = s '{122A3128-2520-11D3-BA71-00C04FBFE08B}'
    }
    TPCC.AllTxns = s 'TPCC Class'
    {
        CurVer = s 'TPCC.AllTxns.1'
    }
    NoRemove CLSID
    {
        ForceRemove {122A3128-2520-11D3-BA71-00C04FBFE08B} = s 'TPCC Class'
        {
            ProgID = s 'TPCC.AllTxns.1'
            VersionIndependentProgID = s 'TPCC.AllTxns'
            InprocServer32 = s '%MODULE%'
            {
                val ThreadingModel = s 'Both'
            }
        }
    }
}
```

### tpcc\_com\_all/src/tpcc\_com\_all\_i.c

```
#pragma warning( disable: 4049 ) /* more than 64k source lines */

/* this ALWAYS GENERATED file contains the IIDs and CLSIDs */

/* link this file in with the server and any clients */

/* File created by MIDL compiler version 5.03.0280 */
/* at Sat Apr 08 16:40:18 2000 */
*/
/* Compiler settings for .\src\tpcc_com_all.idl:
    Oicf (OptLev=i2), W1, Zp8, env=Win32 (32b run), ms_ext, c_ext
    error checks: allocation ref bounds_check enum stub_data
    VC __declspec() decoration level:
        __declspec(uuid()), __declspec(selectany), __declspec(novtable)
    DECLSPEC_UUID(), MIDL_INTERFACE()
*/
//@@MIDL_FILE_HEADING( )

#if !defined(_M_IA64) && !defined(_M_AXP64)

#ifdef __cplusplus
extern "C"{
#endif
```

## Appendix A - Application Source Code

```
#include <rpc.h>
#include <rpcndr.h>

#ifdef _MIDL_USE_GUIDDEF_

#ifndef INITGUID
#define INITGUID
#include <guiddef.h>
#undef INITGUID
#else
#include <guiddef.h>
#endif

#define MIDL_DEFINE_GUID(type,name,l,w1,w2,b1,b2,b3,b4,b5,b6,b7,b8) \
    DEFINE_GUID(name,l,w1,w2,b1,b2,b3,b4,b5,b6,b7,b8)

#else // !_MIDL_USE_GUIDDEF_

#ifndef __IID_DEFINED__
#define __IID_DEFINED__

typedef struct _IID
{
    unsigned long x;
    unsigned short s1;
    unsigned short s2;
    unsigned char c[8];
} IID;

#endif // __IID_DEFINED__

#ifndef CLSID_DEFINED
#define CLSID_DEFINED
typedef IID CLSID;
#endif // CLSID_DEFINED

#define MIDL_DEFINE_GUID(type,name,l,w1,w2,b1,b2,b3,b4,b5,b6,b7,b8) \
    const type name = {l,w1,w2,{b1,b2,b3,b4,b5,b6,b7,b8}}

#endif !_MIDL_USE_GUIDDEF_

MIDL_DEFINE_GUID(IID,
LIBID_TPCCLib,0x122A3117,0x2520,0x11D3,0xBA,0x71,0x00,0xC0,0x4F,0xBF,0xE0,0x8B);

MIDL_DEFINE_GUID(CLSID,
CLSID_TPCC,0x122A3128,0x2520,0x11D3,0xBA,0x71,0x00,0xC0,0x4F,0xBF,0xE0,0x8B);

MIDL_DEFINE_GUID(CLSID,
CLSID_NewOrder,0x975BAABF,0x84A7,0x11D2,0xBA,0x47,0x00,0xC0,0x4F,0xBF,0xE0,0x8B);

MIDL_DEFINE_GUID(CLSID,
CLSID_OrderStatus,0x266836AD,0xA50D,0x11D2,0xBA,0x4E,0x00,0xC0,0x4F,0xBF,0xE0,0x8B);

MIDL_DEFINE_GUID(CLSID,
CLSID_Payment,0xCDD02F7EF,0xA4FA,0x11D2,0xBA,0x4E,0x00,0xC0,0x4F,0xBF,0xE0,0x8B);
```

```
MIDL_DEFINE_GUID(CLSID,
CLSID_StockLevel,0x2668369E,0xA50D,0x11D2,0xBA,0x4E,0x00,0xC0,0x4F,0xBF,0xE0,0x8B);

#undef MIDL_DEFINE_GUID

#ifdef __cplusplus
}
#endif

#endif /* !defined(_M_IA64) && !defined(_M_AXP64) */

#pragma warning( disable: 4049 ) /* more than 64k source lines */

/* this ALWAYS GENERATED file contains the IIDs and CLSIDs */

/* link this file in with the server and any clients */

/* File created by MIDL compiler version 5.03.0280 */
/* at Sat Apr 08 16:40:18 2000 */
*/
/* Compiler settings for .\src\tpcc_com_all.idl:
Oicf (OptLev=i2), W1, Zp8, env=Win64 (32b run,appending), ms_ext, c_ext, robust
error checks: allocation ref bounds_check enum stub_data
VC __declspec() decoration level:
__declspec(uuid()), __declspec(selectany), __declspec(novtable)
DECLSPEC_UUID(), MIDL_INTERFACE()
*/
//@@MIDL_FILE_HEADING( )

#if defined(_M_IA64) || defined(_M_AXP64)

#ifdef __cplusplus
extern "C" {
#endif

#include <rpc.h>
#include <rpcndr.h>

#ifdef _MIDL_USE_GUIDDEF_

#ifndef INITGUID
#define INITGUID
#include <guiddef.h>
#undef INITGUID
#else
#include <guiddef.h>
#endif

#define MIDL_DEFINE_GUID(type,name,l,w1,w2,b1,b2,b3,b4,b5,b6,b7,b8) \
    DEFINE_GUID(name,l,w1,w2,b1,b2,b3,b4,b5,b6,b7,b8)

#else // !_MIDL_USE_GUIDDEF_

#ifndef __IID_DEFINED__
#define __IID_DEFINED__

typedef struct _IID
{
```

# Appendix A - Application Source Code

```
    unsigned long x;
    unsigned short s1;
    unsigned short s2;
    unsigned char c[8];
} IID;

#endif // __IID_DEFINED__

#ifndef CLSID_DEFINED
#define CLSID_DEFINED
typedef IID CLSID;
#endif // CLSID_DEFINED

#define MIDL_DEFINE_GUID(type,name,l,w1,w2,b1,b2,b3,b4,b5,b6,b7,b8) \
    const type name = {l,w1,w2,{b1,b2,b3,b4,b5,b6,b7,b8}}

#endif !_MIDL_USE_GUIDDEF_

MIDL_DEFINE_GUID(IID,
LIBID_TPCCLib,0x122A3117,0x2520,0x11D3,0xBA,0x71,0x00,0xC0,0x4F,0xBF,0xE0,0x8B);

MIDL_DEFINE_GUID(CLSID,
CLSID_TPCC,0x122A3128,0x2520,0x11D3,0xBA,0x71,0x00,0xC0,0x4F,0xBF,0xE0,0x8B);

MIDL_DEFINE_GUID(CLSID,
CLSID_NewOrder,0x975BAABF,0x84A7,0x11D2,0xBA,0x47,0x00,0xC0,0x4F,0xBF,0xE0,0x8B);

MIDL_DEFINE_GUID(CLSID,
CLSID_OrderStatus,0x266836AD,0xA50D,0x11D2,0xBA,0x4E,0x00,0xC0,0x4F,0xBF,0xE0,0x8B);

MIDL_DEFINE_GUID(CLSID,
CLSID_Payment,0xCD02F7EF,0xA4FA,0x11D2,0xBA,0x4E,0x00,0xC0,0x4F,0xBF,0xE0,0x8B);

MIDL_DEFINE_GUID(CLSID,
CLSID_StockLevel,0x2668369E,0xA50D,0x11D2,0xBA,0x4E,0x00,0xC0,0x4F,0xBF,0xE0,0x8B);

#undef MIDL_DEFINE_GUID

#ifdef __cplusplus
}
#endif

#endif /* defined(_M_IA64) || defined(_M_AXP64)*/
```

## tpcc\_com\_all/src/tpcc\_com\_no.rgs

```
HKCR
```

```
{
    TPCC.NewOrder.1 = s 'NewOrder Class'
    {
        CLSID = s '{975BAABF-84A7-11D2-BA47-00C04FBFE08B}'
    }
    TPCC.NewOrder = s 'NewOrder Class'
    {
        CurVer = s 'TPCC.NewOrder.1'
    }
    NoRemove CLSID
    {
        ForceRemove {975BAABF-84A7-11D2-BA47-00C04FBFE08B} = s 'NewOrder'
    }
}

Class'
{
    ProgID = s 'TPCC.NewOrder.1'
    VersionIndependentProgID = s 'TPCC.NewOrder'
    InprocServer32 = s '%MODULE%'
    {
        val ThreadingModel = s 'Both'
    }
}
}
```

## tpcc\_com\_all/src/tpcc\_com\_os.rgs

```
HKCR
```

```
{
    TPCC.OrderStatus.1 = s 'OrderStatus Class'
    {
        CLSID = s '{266836AD-A50D-11D2-BA4E-00C04FBFE08B}'
    }
    TPCC.OrderStatus = s 'OrderStatus Class'
    {
        CurVer = s 'TPCC.OrderStatus.1'
    }
    NoRemove CLSID
    {
        ForceRemove {266836AD-A50D-11D2-BA4E-00C04FBFE08B} = s 'OrderStatus'
    }
}

Class'
{
    ProgID = s 'TPCC.OrderStatus.1'
    VersionIndependentProgID = s 'TPCC.OrderStatus'
    InprocServer32 = s '%MODULE%'
    {
        val ThreadingModel = s 'Both'
    }
}
}
```

## tpcc\_com\_all/src/tpcc\_com\_pay.rgs

```
HKCR
```

```
{
    TPCC.Payment.1 = s 'Payment Class'
```

## Appendix A - Application Source Code

```
{
    CLSID = s '{CD02F7EF-A4FA-11D2-BA4E-00C04FBFE08B}'
}
TPCC.Payment = s 'Payment Class'
{
    CurVer = s 'TPCC.Payment.1'
}
NoRemove CLSID
{
    ForceRemove {CD02F7EF-A4FA-11D2-BA4E-00C04FBFE08B} = s 'Payment
Class'
    {
        ProgID = s 'TPCC.Payment.1'
        VersionIndependentProgID = s 'TPCC.Payment'
        InprocServer32 = s '%MODULE%'
        {
            val ThreadingModel = s 'Both'
        }
    }
}
}
```

### tpcc\_com\_all/src/tpcc\_com\_ps.h

```
#pragma warning( disable: 4049 ) /* more than 64k source lines */
/* this ALWAYS GENERATED file contains the definitions for the interfaces */

/* File created by MIDL compiler version 5.03.0280 */
/* at Sat Apr 08 16:40:10 2000 */
/*
/* Compiler settings for .\src\tpcc_com_ps.idl:
    Oicf (OptLev=i2), W1, Zp8, env=Win32 (32b run), ms_ext, c_ext
    error checks: allocation ref bounds_check enum stub_data
    VC __declspec() decoration level:
        __declspec(uuid()), __declspec(selectany), __declspec(novtable)
    DECLSPEC_UUID(), MIDL_INTERFACE()
*/
//@@MIDL_FILE_HEADING( )

/* verify that the <rpcndr.h> version is high enough to compile this file*/
#ifndef __REQUIRED_RPCNDR_H_VERSION__
#define __REQUIRED_RPCNDR_H_VERSION__ 440
#endif

#include "rpc.h"
#include "rpcndr.h"

#ifndef __RPCNDR_H_VERSION__
#error this stub requires an updated version of <rpcndr.h>
#endif // __RPCNDR_H_VERSION__

#ifndef COM_NO_WINDOWS_H
#include "windows.h"

```

```
#include "ole2.h"
#endif /*COM_NO_WINDOWS_H*/

#ifndef __tpcc_com_ps_h__
#define __tpcc_com_ps_h__

/* Forward Declarations */

#ifndef __ITPCC_FWD_DEFINED__
#define __ITPCC_FWD_DEFINED__
typedef interface ITPCC ITPCC;
#endif /* __ITPCC_FWD_DEFINED__ */

/* header files for imported files */
#include "oaidl.h"
#include "ocidl.h"

#ifndef __cplusplus
extern "C"{
#endif

void __RPC_FAR * __RPC_USER MIDL_user_allocate(size_t);
void __RPC_USER MIDL_user_free( void __RPC_FAR * );

/* interface __MIDL_itf_tpcc_com_ps_0000 */
/* [local] */

extern RPC_IF_HANDLE __MIDL_itf_tpcc_com_ps_0000_v0_0_c_ifspec;
extern RPC_IF_HANDLE __MIDL_itf_tpcc_com_ps_0000_v0_0_s_ifspec;

#ifndef __ITPCC_INTERFACE_DEFINED__
#define __ITPCC_INTERFACE_DEFINED__

/* interface ITPCC */
/* [unique][helpstring][uuid][oleautomation][object] */

EXTERN_C const IID IID_ITPCC;

#if defined(__cplusplus) && !defined(CINTERFACE)

MIDL_INTERFACE("FEEE6AA2-84B1-11d2-BA47-00C04FBFE08B")
ITPCC : public IUnknown
{
public:
    virtual HRESULT STDMETHODCALLTYPE NewOrder(
        /* [in] */ VARIANT txn_in,
        /* [out] */ VARIANT __RPC_FAR *txn_out) = 0;

    virtual HRESULT STDMETHODCALLTYPE Payment(
        /* [in] */ VARIANT txn_in,
        /* [out] */ VARIANT __RPC_FAR *txn_out) = 0;

    virtual HRESULT STDMETHODCALLTYPE Delivery(
        /* [in] */ VARIANT txn_in,
        /* [out] */ VARIANT __RPC_FAR *txn_out) = 0;

    virtual HRESULT STDMETHODCALLTYPE StockLevel(
        /* [in] */ VARIANT txn_in,

```

## Appendix A - Application Source Code

```
        /* [out] */ VARIANT __RPC_FAR *txn_out) = 0;

virtual HRESULT __stdcall OrderStatus(
    /* [in] */ VARIANT txn_in,
    /* [out] */ VARIANT __RPC_FAR *txn_out) = 0;

virtual HRESULT __stdcall CallSetComplete( void) = 0;
};

#else /* C style interface */

typedef struct ITPCCVtbl
{
    BEGIN_INTERFACE

    HRESULT ( STDMETHODCALLTYPE __RPC_FAR *QueryInterface )(
        ITPCC __RPC_FAR * This,
        /* [in] */ REFIID riid,
        /* [iid_is][out] */ void __RPC_FAR *__RPC_FAR *ppvObject);

    ULONG ( STDMETHODCALLTYPE __RPC_FAR *AddRef )(
        ITPCC __RPC_FAR * This);

    ULONG ( STDMETHODCALLTYPE __RPC_FAR *Release )(
        ITPCC __RPC_FAR * This);

    HRESULT ( __stdcall __RPC_FAR *NewOrder )(
        ITPCC __RPC_FAR * This,
        /* [in] */ VARIANT txn_in,
        /* [out] */ VARIANT __RPC_FAR *txn_out);

    HRESULT ( __stdcall __RPC_FAR *Payment )(
        ITPCC __RPC_FAR * This,
        /* [in] */ VARIANT txn_in,
        /* [out] */ VARIANT __RPC_FAR *txn_out);

    HRESULT ( __stdcall __RPC_FAR *Delivery )(
        ITPCC __RPC_FAR * This,
        /* [in] */ VARIANT txn_in,
        /* [out] */ VARIANT __RPC_FAR *txn_out);

    HRESULT ( __stdcall __RPC_FAR *StockLevel )(
        ITPCC __RPC_FAR * This,
        /* [in] */ VARIANT txn_in,
        /* [out] */ VARIANT __RPC_FAR *txn_out);

    HRESULT ( __stdcall __RPC_FAR *OrderStatus )(
        ITPCC __RPC_FAR * This,
        /* [in] */ VARIANT txn_in,
        /* [out] */ VARIANT __RPC_FAR *txn_out);

    HRESULT ( __stdcall __RPC_FAR *CallSetComplete )(
        ITPCC __RPC_FAR * This);

    END_INTERFACE
} ITPCCVtbl;

interface ITPCC
{
    CONST_VTBL struct ITPCCVtbl __RPC_FAR *lpVtbl;
};
```

```
#ifdef COBJMACROS

#define ITPCC_QueryInterface(This,riid,ppvObject)\
    (This->lpVtbl -> QueryInterface(This,riid,ppvObject))

#define ITPCC_AddRef(This) \
    (This->lpVtbl -> AddRef(This))

#define ITPCC_Release(This) \
    (This->lpVtbl -> Release(This))

#define ITPCC_NewOrder(This,txn_in,txn_out) \
    (This->lpVtbl -> NewOrder(This,txn_in,txn_out))

#define ITPCC_Payment(This,txn_in,txn_out) \
    (This->lpVtbl -> Payment(This,txn_in,txn_out))

#define ITPCC_Delivery(This,txn_in,txn_out) \
    (This->lpVtbl -> Delivery(This,txn_in,txn_out))

#define ITPCC_StockLevel(This,txn_in,txn_out) \
    (This->lpVtbl -> StockLevel(This,txn_in,txn_out))

#define ITPCC_OrderStatus(This,txn_in,txn_out) \
    (This->lpVtbl -> OrderStatus(This,txn_in,txn_out))

#define ITPCC_CallSetComplete(This) \
    (This->lpVtbl -> CallSetComplete(This))

#endif /* COBJMACROS */

#endif /* C style interface */

HRESULT __stdcall ITPCC_NewOrder_Proxy(
    ITPCC __RPC_FAR * This,
    /* [in] */ VARIANT txn_in,
    /* [out] */ VARIANT __RPC_FAR *txn_out);

void __RPC_STUB ITPCC_NewOrder_Stub(
    IRpcStubBuffer *This,
    IRpcChannelBuffer *_pRpcChannelBuffer,
    PRPC_MESSAGE _pRpcMessage,
    DWORD *_pdwStubPhase);

HRESULT __stdcall ITPCC_Payment_Proxy(
    ITPCC __RPC_FAR * This,
    /* [in] */ VARIANT txn_in,
    /* [out] */ VARIANT __RPC_FAR *txn_out);

void __RPC_STUB ITPCC_Payment_Stub(
    IRpcStubBuffer *This,
    IRpcChannelBuffer *_pRpcChannelBuffer,
    PRPC_MESSAGE _pRpcMessage,
```

# Appendix A - Application Source Code

```
DWORD *_pdwStubPhase);

HRESULT __stdcall ITPCC_Delivery_Proxy(
    ITPCC __RPC_FAR * This,
    /* [in] */ VARIANT txn_in,
    /* [out] */ VARIANT __RPC_FAR *txn_out);

void __RPC_STUB ITPCC_Delivery_Stub(
    IRpcStubBuffer *This,
    IRpcChannelBuffer *_pRpcChannelBuffer,
    PRPC_MESSAGE _pRpcMessage,
    DWORD *_pdwStubPhase);

HRESULT __stdcall ITPCC_StockLevel_Proxy(
    ITPCC __RPC_FAR * This,
    /* [in] */ VARIANT txn_in,
    /* [out] */ VARIANT __RPC_FAR *txn_out);

void __RPC_STUB ITPCC_StockLevel_Stub(
    IRpcStubBuffer *This,
    IRpcChannelBuffer *_pRpcChannelBuffer,
    PRPC_MESSAGE _pRpcMessage,
    DWORD *_pdwStubPhase);

HRESULT __stdcall ITPCC_OrderStatus_Proxy(
    ITPCC __RPC_FAR * This,
    /* [in] */ VARIANT txn_in,
    /* [out] */ VARIANT __RPC_FAR *txn_out);

void __RPC_STUB ITPCC_OrderStatus_Stub(
    IRpcStubBuffer *This,
    IRpcChannelBuffer *_pRpcChannelBuffer,
    PRPC_MESSAGE _pRpcMessage,
    DWORD *_pdwStubPhase);

HRESULT __stdcall ITPCC_CallSetComplete_Proxy(
    ITPCC __RPC_FAR * This);

void __RPC_STUB ITPCC_CallSetComplete_Stub(
    IRpcStubBuffer *This,
    IRpcChannelBuffer *_pRpcChannelBuffer,
    PRPC_MESSAGE _pRpcMessage,
    DWORD *_pdwStubPhase);

#endif /* __ITPCC_INTERFACE_DEFINED__ */

/* Additional Prototypes for ALL interfaces */

unsigned long             __RPC_USER  VARIANT_UserSize(      unsigned long __RPC_FAR *,
unsigned long             , VARIANT __RPC_FAR * );
unsigned char __RPC_FAR * __RPC_USER  VARIANT_UserMarshal(  unsigned long __RPC_FAR *,
unsigned char __RPC_FAR * , VARIANT __RPC_FAR * );
```

```
unsigned char __RPC_FAR * __RPC_USER  VARIANT_UserUnmarshal(unsigned long __RPC_FAR *,
unsigned char __RPC_FAR * , VARIANT __RPC_FAR * );
void             __RPC_USER  VARIANT_UserFree(      unsigned long __RPC_FAR *,
VARIANT __RPC_FAR * );

/* end of Additional Prototypes */

#ifdef __cplusplus
}
#endif
#endif
```

## tpcc\_com\_all/src/tpcc\_com\_sl.rgs

```
HKCR
{
    TPCC.StockLevel.1 = s 'StockLevel Class'
    {
        CLSID = s '{2668369E-A50D-11D2-BA4E-00C04FBFE08B}'
    }
    TPCC.StockLevel = s 'StockLevel Class'
    {
        CurVer = s 'TPCC.StockLevel.1'
    }
    NoRemove CLSID
    {
        ForceRemove {2668369E-A50D-11D2-BA4E-00C04FBFE08B} = s 'StockLevel
Class'
    {
        ProgID = s 'TPCC.StockLevel.1'
        VersionIndependentProgID = s 'TPCC.StockLevel'
        InprocServer32 = s '%MODULE%'
        {
            val ThreadingModel = s 'Both'
        }
    }
    }
}
```

## tpcc\_com\_ps/src/dlldata.c

```
/*
*****
DllData file -- generated by MIDL compiler

DO NOT ALTER THIS FILE

This file is regenerated by MIDL on every IDL file compile.

To completely reconstruct this file, delete it and rerun MIDL
on all the IDL files in this DLL, specifying this file for the
```

## Appendix A - Application Source Code

```

    /dlldata command line option
*****/

#include <rpcproxy.h>

#ifdef __cplusplus
extern "C" {
#endif

EXTERN_PROXY_FILE( tpcc_com_ps )

PROXYFILE_LIST_START
/* Start of list */
    REFERENCE_PROXY_FILE( tpcc_com_ps ),
/* End of list */
PROXYFILE_LIST_END

DLLDATA_ROUTINES( aProxyFileList, GET_DLL_CLSID )

#ifdef __cplusplus
} /*extern "C" */
#endif

/* end of generated dlldata file */
```

### tpcc\_com\_ps/src/tpcc\_com\_ps.def

```
LIBRARY      "tpcc_com_ps"

DESCRIPTION  'Proxy/Stub DLL'

EXPORTS
    DllGetClassObject      @1 PRIVATE
    DllCanUnloadNow        @2 PRIVATE
    GetProxyDllInfo        @3 PRIVATE
    DllRegisterServer      @4 PRIVATE
    DllUnregisterServer    @5 PRIVATE
```

### tpcc\_com\_ps/src/tpcc\_com\_ps.h

```
#pragma warning( disable: 4049 ) /* more than 64k source lines */

/* this ALWAYS GENERATED file contains the definitions for the interfaces */

/* File created by MIDL compiler version 5.03.0280 */
/* at Sat Apr 08 16:40:10 2000
*/
```

```

/* Compiler settings for .\src\tpcc_com_ps.idl:
    Oicf (OptLev=i2), W1, Zp8, env=Win32 (32b run), ms_ext, c_ext
    error checks: allocation ref bounds_check enum stub_data
    VC __declspec() decoration level:
        __declspec(uuid()), __declspec(selectany), __declspec(novtable)
        DECLSPEC_UUID(), MIDL_INTERFACE()
*/
//@@MIDL_FILE_HEADING(  )

/* verify that the <rpcndr.h> version is high enough to compile this file*/
#ifdef __REQUIRED_RPCNDR_H_VERSION__
#define __REQUIRED_RPCNDR_H_VERSION__ 440
#endif

#include "rpc.h"
#include "rpcndr.h"

#ifdef __RPCNDR_H_VERSION__
#error this stub requires an updated version of <rpcndr.h>
#endif // __RPCNDR_H_VERSION__

#ifdef COM_NO_WINDOWS_H
#include "windows.h"
#include "ole2.h"
#endif /*COM_NO_WINDOWS_H*/

#ifdef __tpcc_com_ps_h__
#define __tpcc_com_ps_h__

/* Forward Declarations */

#ifdef __ITPCC_FWD_DEFINED__
#define __ITPCC_FWD_DEFINED__
typedef interface ITPCC ITPCC;
#endif /* __ITPCC_FWD_DEFINED__ */

/* header files for imported files */
#include "oaidl.h"
#include "ocidl.h"

#ifdef __cplusplus
extern "C"{
#endif

void __RPC_FAR * __RPC_USER MIDL_user_allocate(size_t);
void __RPC_USER MIDL_user_free( void __RPC_FAR * );

/* interface __MIDL_itf_tpcc_com_ps_0000 */
/* [local] */

extern RPC_IF_HANDLE __MIDL_itf_tpcc_com_ps_0000_v0_0_c_ifspec;
extern RPC_IF_HANDLE __MIDL_itf_tpcc_com_ps_0000_v0_0_s_ifspec;

#ifdef __ITPCC_INTERFACE_DEFINED__
#define __ITPCC_INTERFACE_DEFINED__

/* interface ITPCC */
/* [unique][helpstring][uuid][oleautomation][object] */
```

## Appendix A - Application Source Code

```
EXTERN_C const IID IID_ITPCC;

#if defined(__cplusplus) && !defined(CINTERFACE)

MIDL_INTERFACE("FEEE6AA2-84B1-11d2-BA47-00C04FBFE08B")
ITPCC : public IUnknown
{
public:
    virtual HRESULT STDMETHODCALLTYPE NewOrder(
        /* [in] */ VARIANT txn_in,
        /* [out] */ VARIANT __RPC_FAR *txn_out) = 0;

    virtual HRESULT STDMETHODCALLTYPE Payment(
        /* [in] */ VARIANT txn_in,
        /* [out] */ VARIANT __RPC_FAR *txn_out) = 0;

    virtual HRESULT STDMETHODCALLTYPE Delivery(
        /* [in] */ VARIANT txn_in,
        /* [out] */ VARIANT __RPC_FAR *txn_out) = 0;

    virtual HRESULT STDMETHODCALLTYPE StockLevel(
        /* [in] */ VARIANT txn_in,
        /* [out] */ VARIANT __RPC_FAR *txn_out) = 0;

    virtual HRESULT STDMETHODCALLTYPE OrderStatus(
        /* [in] */ VARIANT txn_in,
        /* [out] */ VARIANT __RPC_FAR *txn_out) = 0;

    virtual HRESULT STDMETHODCALLTYPE CallSetComplete( void) = 0;

};

#else /* C style interface */

typedef struct ITPCCVtbl
{
    BEGIN_INTERFACE

    HRESULT ( STDMETHODCALLTYPE __RPC_FAR *QueryInterface )(
        ITPCC __RPC_FAR * This,
        /* [in] */ REFIID riid,
        /* [iid_is][out] */ void __RPC_FAR *__RPC_FAR *ppvObject);

    ULONG ( STDMETHODCALLTYPE __RPC_FAR *AddRef )(
        ITPCC __RPC_FAR * This);

    ULONG ( STDMETHODCALLTYPE __RPC_FAR *Release )(
        ITPCC __RPC_FAR * This);

    HRESULT ( STDMETHODCALLTYPE __RPC_FAR *NewOrder )(
        ITPCC __RPC_FAR * This,
        /* [in] */ VARIANT txn_in,
        /* [out] */ VARIANT __RPC_FAR *txn_out);

    HRESULT ( STDMETHODCALLTYPE __RPC_FAR *Payment )(
        ITPCC __RPC_FAR * This,
        /* [in] */ VARIANT txn_in,
        /* [out] */ VARIANT __RPC_FAR *txn_out);

    HRESULT ( STDMETHODCALLTYPE __RPC_FAR *Delivery )(
        ITPCC __RPC_FAR * This,
```

```
        /* [in] */ VARIANT txn_in,
        /* [out] */ VARIANT __RPC_FAR *txn_out);

    HRESULT ( STDMETHODCALLTYPE __RPC_FAR *StockLevel )(
        ITPCC __RPC_FAR * This,
        /* [in] */ VARIANT txn_in,
        /* [out] */ VARIANT __RPC_FAR *txn_out);

    HRESULT ( STDMETHODCALLTYPE __RPC_FAR *OrderStatus )(
        ITPCC __RPC_FAR * This,
        /* [in] */ VARIANT txn_in,
        /* [out] */ VARIANT __RPC_FAR *txn_out);

    HRESULT ( STDMETHODCALLTYPE __RPC_FAR *CallSetComplete )(
        ITPCC __RPC_FAR * This);

    END_INTERFACE
} ITPCCVtbl;

interface ITPCC
{
    CONST_VTBL struct ITPCCVtbl __RPC_FAR *lpVtbl;
};

#ifdef COBJMACROS

#define ITPCC_QueryInterface(This,riid,ppvObject)\
    (This->lpVtbl -> QueryInterface(This,riid,ppvObject))

#define ITPCC_AddRef(This) \
    (This->lpVtbl -> AddRef(This))

#define ITPCC_Release(This) \
    (This->lpVtbl -> Release(This))

#define ITPCC_NewOrder(This,txn_in,txn_out) \
    (This->lpVtbl -> NewOrder(This,txn_in,txn_out))

#define ITPCC_Payment(This,txn_in,txn_out) \
    (This->lpVtbl -> Payment(This,txn_in,txn_out))

#define ITPCC_Delivery(This,txn_in,txn_out) \
    (This->lpVtbl -> Delivery(This,txn_in,txn_out))

#define ITPCC_StockLevel(This,txn_in,txn_out) \
    (This->lpVtbl -> StockLevel(This,txn_in,txn_out))

#define ITPCC_OrderStatus(This,txn_in,txn_out) \
    (This->lpVtbl -> OrderStatus(This,txn_in,txn_out))

#define ITPCC_CallSetComplete(This) \
    (This->lpVtbl -> CallSetComplete(This))

#endif /* COBJMACROS */

#endif /* C style interface */
```

## Appendix A - Application Source Code

```
HRESULT __stdcall ITPCC_NewOrder_Proxy(
    ITPCC __RPC_FAR * This,
    /* [in] */ VARIANT txn_in,
    /* [out] */ VARIANT __RPC_FAR *txn_out);

void __RPC_STUB ITPCC_NewOrder_Stub(
    IRpcStubBuffer *This,
    IRpcChannelBuffer *_pRpcChannelBuffer,
    PRPC_MESSAGE _pRpcMessage,
    DWORD *_pdwStubPhase);

HRESULT __stdcall ITPCC_Payment_Proxy(
    ITPCC __RPC_FAR * This,
    /* [in] */ VARIANT txn_in,
    /* [out] */ VARIANT __RPC_FAR *txn_out);

void __RPC_STUB ITPCC_Payment_Stub(
    IRpcStubBuffer *This,
    IRpcChannelBuffer *_pRpcChannelBuffer,
    PRPC_MESSAGE _pRpcMessage,
    DWORD *_pdwStubPhase);

HRESULT __stdcall ITPCC_Delivery_Proxy(
    ITPCC __RPC_FAR * This,
    /* [in] */ VARIANT txn_in,
    /* [out] */ VARIANT __RPC_FAR *txn_out);

void __RPC_STUB ITPCC_Delivery_Stub(
    IRpcStubBuffer *This,
    IRpcChannelBuffer *_pRpcChannelBuffer,
    PRPC_MESSAGE _pRpcMessage,
    DWORD *_pdwStubPhase);

HRESULT __stdcall ITPCC_StockLevel_Proxy(
    ITPCC __RPC_FAR * This,
    /* [in] */ VARIANT txn_in,
    /* [out] */ VARIANT __RPC_FAR *txn_out);

void __RPC_STUB ITPCC_StockLevel_Stub(
    IRpcStubBuffer *This,
    IRpcChannelBuffer *_pRpcChannelBuffer,
    PRPC_MESSAGE _pRpcMessage,
    DWORD *_pdwStubPhase);

HRESULT __stdcall ITPCC_OrderStatus_Proxy(
    ITPCC __RPC_FAR * This,
    /* [in] */ VARIANT txn_in,
    /* [out] */ VARIANT __RPC_FAR *txn_out);

void __RPC_STUB ITPCC_OrderStatus_Stub(
    IRpcStubBuffer *This,
    IRpcChannelBuffer *_pRpcChannelBuffer,
    PRPC_MESSAGE _pRpcMessage,
```

```
DWORD *_pdwStubPhase);

HRESULT __stdcall ITPCC_CallSetComplete_Proxy(
    ITPCC __RPC_FAR * This);

void __RPC_STUB ITPCC_CallSetComplete_Stub(
    IRpcStubBuffer *This,
    IRpcChannelBuffer *_pRpcChannelBuffer,
    PRPC_MESSAGE _pRpcMessage,
    DWORD *_pdwStubPhase);

#endif /* __ITPCC_INTERFACE_DEFINED__ */

/* Additional Prototypes for ALL interfaces */

unsigned long             __RPC_USER VARIANT_UserSize(      unsigned long __RPC_FAR *,
unsigned long             , VARIANT __RPC_FAR * );
unsigned char __RPC_FAR * __RPC_USER VARIANT_UserMarshal(  unsigned long __RPC_FAR *,
unsigned char __RPC_FAR *, VARIANT __RPC_FAR * );
unsigned char __RPC_FAR * __RPC_USER VARIANT_UserUnmarshal(unsigned long __RPC_FAR *,
unsigned char __RPC_FAR *, VARIANT __RPC_FAR * );
void                    __RPC_USER VARIANT_UserFree(      unsigned long __RPC_FAR *,
VARIANT __RPC_FAR * );

/* end of Additional Prototypes */

#ifdef __cplusplus
}
#endif

#endif
```

### tpcc\_com\_ps/src/tpcc\_com\_ps.idl

```
/* FILE: ITPCC.IDL
 * Microsoft TPC-C Kit Ver. 4.20.000
 * Copyright Microsoft, 1999
 * All Rights Reserved
 *
 * not yet audited
 *
 * PURPOSE: Defines the interface used by TPCC. This
interface can be implemented by C++ components.
 *
 * Change history:
 * 4.20.000 - first version
```

## Appendix A - Application Source Code

```
*/
// Forward declare all types defined
interface ITPCC;
import "oidl.idl";
import "ocidl.idl";

[
    object,
    oleautomation,
    uuid(FEEE6AA2-84B1-11d2-BA47-00C04FBFE08B),
    helpstring("ITPCC Interface"),
    pointer_default(unique)
]
interface ITPCC : IUnknown
{
    HRESULT STDMETHODCALLTYPE NewOrder
        (
            [in] VARIANT txn_in,
            [out] VARIANT *txn_out
        );

    HRESULT STDMETHODCALLTYPE Payment
        (
            [in] VARIANT txn_in,
            [out] VARIANT *txn_out
        );

    HRESULT STDMETHODCALLTYPE Delivery
        (
            [in] VARIANT txn_in,
            [out] VARIANT *txn_out
        );

    HRESULT STDMETHODCALLTYPE StockLevel
        (
            [in] VARIANT txn_in,
            [out] VARIANT *txn_out
        );

    HRESULT STDMETHODCALLTYPE OrderStatus
        (
            [in] VARIANT txn_in,
            [out] VARIANT *txn_out
        );
}
```

```
HRESULT STDMETHODCALLTYPE CallSetComplete
(
);

}; // interface ITPCC
```

### tpcc\_com\_ps/src/tpcc\_com\_ps\_i.c

```
#pragma warning( disable: 4049 ) /* more than 64k source lines */
/* this ALWAYS GENERATED file contains the IIDs and CLSIDs */
/* link this file in with the server and any clients */

/* File created by MIDL compiler version 5.03.0280 */
/* at Sat Apr 08 16:40:10 2000 */
/*
 * Compiler settings for .\src\tpcc_com_ps.idl:
 * Oicf (OptLev=12), W1, Zp8, env=Win32 (32b run), ms_ext, c_ext
 * error checks: allocation ref bounds_check enum stub_data
 * VC __declspec() decoration level:
 * __declspec(uuid()), __declspec(selectany), __declspec(novtable)
 * DECLSPEC_UUID(), MIDL_INTERFACE()
 */
//@@MIDL_FILE_HEADING( )

#if !defined(_M_IA64) && !defined(_M_AXP64)

#ifdef __cplusplus
extern "C"{
#endif

#include <rpc.h>
#include <rpcndr.h>

#ifdef _MIDL_USE_GUIDDEF_

#ifndef INITGUID
#define INITGUID
#include <guiddef.h>
#undef INITGUID
#else
#include <guiddef.h>
#endif

#define MIDL_DEFINE_GUID(type,name,l,w1,w2,b1,b2,b3,b4,b5,b6,b7,b8) \
    DEFINE_GUID(name,l,w1,w2,b1,b2,b3,b4,b5,b6,b7,b8)

#else // !_MIDL_USE_GUIDDEF_
```

# Appendix A - Application Source Code

```
#ifndef __IID_DEFINED__
#define __IID_DEFINED__

typedef struct _IID
{
    unsigned long x;
    unsigned short s1;
    unsigned short s2;
    unsigned char c[8];
} IID;

#endif // __IID_DEFINED__

#ifndef CLSID_DEFINED
#define CLSID_DEFINED
typedef IID CLSID;
#endif // CLSID_DEFINED

#define MIDL_DEFINE_GUID(type,name,l,w1,w2,b1,b2,b3,b4,b5,b6,b7,b8) \
    const type name = {l,w1,w2,{b1,b2,b3,b4,b5,b6,b7,b8}}

#endif !_MIDL_USE_GUIDDEF_

MIDL_DEFINE_GUID(IID,
IID_ITPCC,0xFEE6AA2,0x84B1,0x11d2,0xBA,0x47,0x00,0xC0,0x4F,0xBF,0xE0,0x8B);

#undef MIDL_DEFINE_GUID

#ifdef __cplusplus
}
#endif

#endif /* !defined(_M_IA64) && !defined(_M_AXP64)*/

#pragma warning( disable: 4049 ) /* more than 64k source lines */

/* this ALWAYS GENERATED file contains the IIDs and CLSIDs */

/* link this file in with the server and any clients */

/* File created by MIDL compiler version 5.03.0280 */
/* at Sat Apr 08 16:40:10 2000 */
/*
 * Compiler settings for .\src\tpcc_com_ps.idl:
 * Oicf (OptLev=i2), W1, Zp8, env=Win64 (32b run,appending), ms_ext, c_ext, robust
 * error checks: allocation ref bounds_check enum stub_data
 * VC __declspec() decoration level:
 *   __declspec(uuid()), __declspec(selectany), __declspec(novtable)
 *   DECLSPEC_UUID(), MIDL_INTERFACE()
 */
//@@MIDL_FILE_HEADING( )

#ifdef defined(_M_IA64) || defined(_M_AXP64)

#ifdef __cplusplus
extern "C"{
#endif
#endif
```

```
#include <rpc.h>
#include <rpcndr.h>

#ifdef _MIDL_USE_GUIDDEF_

#ifndef INITGUID
#define INITGUID
#include <guiddef.h>
#undef INITGUID
#else
#include <guiddef.h>
#endif

#define MIDL_DEFINE_GUID(type,name,l,w1,w2,b1,b2,b3,b4,b5,b6,b7,b8) \
    DEFINE_GUID(name,l,w1,w2,b1,b2,b3,b4,b5,b6,b7,b8)

#else // !_MIDL_USE_GUIDDEF_

#ifndef __IID_DEFINED__
#define __IID_DEFINED__

typedef struct _IID
{
    unsigned long x;
    unsigned short s1;
    unsigned short s2;
    unsigned char c[8];
} IID;

#endif // __IID_DEFINED__

#ifndef CLSID_DEFINED
#define CLSID_DEFINED
typedef IID CLSID;
#endif // CLSID_DEFINED

#define MIDL_DEFINE_GUID(type,name,l,w1,w2,b1,b2,b3,b4,b5,b6,b7,b8) \
    const type name = {l,w1,w2,{b1,b2,b3,b4,b5,b6,b7,b8}}

#endif !_MIDL_USE_GUIDDEF_

MIDL_DEFINE_GUID(IID,
IID_ITPCC,0xFEE6AA2,0x84B1,0x11d2,0xBA,0x47,0x00,0xC0,0x4F,0xBF,0xE0,0x8B);

#undef MIDL_DEFINE_GUID

#ifdef __cplusplus
}
#endif

#endif /* defined(_M_IA64) || defined(_M_AXP64)*/
```

tpcc\_com\_ps/src/tpcc\_com\_ps\_p.c

# Appendix A - Application Source Code

```
#pragma warning( disable: 4049 ) /* more than 64k source lines */

/* this ALWAYS GENERATED file contains the proxy stub code */

/* File created by MIDL compiler version 5.03.0280 */
/* at Sat Apr 08 16:40:10 2000
*/
/* Compiler settings for .\src\tpcc_com.ps.idl:
   Oicf (OptLev=i2), W1, Zp8, env=Win32 (32b run), ms_ext, c_ext
   error checks: allocation ref bounds_check enum stub_data
   VC __declspec() decoration level:
       __declspec(uuid()), __declspec(selectany), __declspec(novtable)
   DECLSPEC_UUID(), MIDL_INTERFACE()
*/
//@@MIDL_FILE_HEADING( )

#if !defined(_M_IA64) && !defined(_M_AXP64)
#define USE_STUBLESS_PROXY

/* verify that the <rpcproxy.h> version is high enough to compile this file*/
#ifndef __REDQ_RPCPROXY_H_VERSION__
#define __REQUIRED_RPCPROXY_H_VERSION__ 440
#endif

#include "rpcproxy.h"
#ifndef __RPCPROXY_H_VERSION__
#error this stub requires an updated version of <rpcproxy.h>
#endif // __RPCPROXY_H_VERSION__

#include "tpcc_com.ps.h"

#define TYPE_FORMAT_STRING_SIZE 997
#define PROC_FORMAT_STRING_SIZE 193
#define TRANSMIT_AS_TABLE_SIZE 0
#define WIRE_MARSHAL_TABLE_SIZE 1

typedef struct _MIDL_TYPE_FORMAT_STRING
{
    short          Pad;
    unsigned char  Format[ TYPE_FORMAT_STRING_SIZE ];
} MIDL_TYPE_FORMAT_STRING;

typedef struct _MIDL_PROC_FORMAT_STRING
{
    short          Pad;
    unsigned char  Format[ PROC_FORMAT_STRING_SIZE ];
} MIDL_PROC_FORMAT_STRING;

extern const MIDL_TYPE_FORMAT_STRING __MIDL_TypeFormatString;
extern const MIDL_PROC_FORMAT_STRING __MIDL_ProcFormatString;

/* Standard interface: __MIDL_itf_tpcc_com_0000, ver. 0.0,
   GUID={0x00000000,0x0000,0x0000,{0x00,0x00,0x00,0x00,0x00,0x00,0x00,0x00}} */
```

```
/* Object interface: IUnknown, ver. 0.0,
   GUID={0x00000000,0x0000,0x0000,{0xC0,0x00,0x00,0x00,0x00,0x00,0x00,0x46}} */

/* Object interface: ITPCC, ver. 0.0,
   GUID={0xFEE6AA2,0x84B1,0x11d2,{0xBA,0x47,0x00,0xC0,0x4F,0xBF,0xE0,0x8B}} */

extern const MIDL_STUB_DESC Object_StubDesc;

extern const MIDL_SERVER_INFO ITPCC_ServerInfo;

#pragma code_seg(".orpc")
static const unsigned short ITPCC_FormatStringOffsetTable[] =
{
    0,
    34,
    68,
    102,
    136,
    170
};

static const MIDL_SERVER_INFO ITPCC_ServerInfo =
{
    &Object_StubDesc,
    0,
    __MIDL_ProcFormatString.Format,
    &ITPCC_FormatStringOffsetTable[-3],
    0,
    0,
    0,
    0
};

static const MIDL_STUBLESS_PROXY_INFO ITPCC_ProxyInfo =
{
    &Object_StubDesc,
    __MIDL_ProcFormatString.Format,
    &ITPCC_FormatStringOffsetTable[-3],
    0,
    0,
    0
};

CINTERFACE_PROXY_VTABLE(9) _ITPCCProxyVtbl =
{
    &ITPCC_ProxyInfo,
    &IID_ITPCC,
    IUnknown_QueryInterface_Proxy,
    IUnknown_AddRef_Proxy,
    IUnknown_Release_Proxy ,
    (void *)-1 /* ITPCC::NewOrder */ ,
    (void *)-1 /* ITPCC::Payment */ ,
    (void *)-1 /* ITPCC::Delivery */ ,
    (void *)-1 /* ITPCC::StockLevel */ ,
    (void *)-1 /* ITPCC::OrderStatus */ ,
    (void *)-1 /* ITPCC::CallSetComplete */
};

const CInterfaceStubVtbl _ITPCCStubVtbl =
{
```



# Appendix A - Application Source Code

```

                                NdrFcShort( 0x18 ), /* Alpha Stack size/offset = 24 */
#endif
/* 26 */ NdrFcShort( 0x3da ), /* Type Offset=986 */

/* Return value */

/* 28 */ NdrFcShort( 0x70 ), /* Flags: out, return, base type, */
#ifndef _ALPHA_
#ifndef _PPC_
#ifndef _MIPS_
/* 30 */ NdrFcShort( 0x18 ), /* x86 Stack size/offset = 24 */
#else
                                NdrFcShort( 0x1c ), /* MIPS Stack size/offset = 28 */
#endif
#else
                                NdrFcShort( 0x1c ), /* PPC Stack size/offset = 28 */
#endif
#else
                                NdrFcShort( 0x20 ), /* Alpha Stack size/offset = 32 */
#endif
/* 32 */ 0x8, /* FC_LONG */
0x0, /* 0 */

/* Procedure Payment */

/* 34 */ 0x33, /* FC_AUTO_HANDLE */
0x6c, /* Old Flags: object, Oi2 */
/* 36 */ NdrFcLong( 0x0 ), /* 0 */
/* 40 */ NdrFcShort( 0x4 ), /* 4 */
#ifndef _ALPHA_
#ifndef _PPC_
#ifndef _MIPS_
/* 42 */ NdrFcShort( 0x1c ), /* x86 Stack size/offset = 28 */
#else
                                NdrFcShort( 0x20 ), /* MIPS Stack size/offset = 32 */
#endif
#else
                                NdrFcShort( 0x20 ), /* PPC Stack size/offset = 32 */
#endif
#else
                                NdrFcShort( 0x28 ), /* Alpha Stack size/offset = 40 */
#endif
/* 44 */ NdrFcShort( 0x0 ), /* 0 */
/* 46 */ NdrFcShort( 0x8 ), /* 8 */
/* 48 */ 0x7, /* Oi2 Flags: srv must size, clt must size, has return, */
0x3, /* 3 */

/* Parameter txn_in */

/* 50 */ NdrFcShort( 0x8b ), /* Flags: must size, must free, in, by val, */
#ifndef _ALPHA_
#ifndef _PPC_
#ifndef _MIPS_
/* 52 */ NdrFcShort( 0x4 ), /* x86 Stack size/offset = 4 */
#else
                                NdrFcShort( 0x8 ), /* MIPS Stack size/offset = 8 */
#endif
#else
                                NdrFcShort( 0x8 ), /* PPC Stack size/offset = 8 */
#endif
#else
                                NdrFcShort( 0x8 ), /* Alpha Stack size/offset = 8 */
#endif
#endif
```

```

/* 54 */ NdrFcShort( 0x3c8 ), /* Type Offset=968 */

/* Parameter txn_out */

/* 56 */ NdrFcShort( 0x4113 ), /* Flags: must size, must free, out, simple ref,
srv alloc size=16 */
#ifndef _ALPHA_
#ifndef _PPC_
#ifndef _MIPS_
/* 58 */ NdrFcShort( 0x14 ), /* x86 Stack size/offset = 20 */
#else
                                NdrFcShort( 0x18 ), /* MIPS Stack size/offset = 24 */
#endif
#else
                                NdrFcShort( 0x18 ), /* PPC Stack size/offset = 24 */
#endif
#else
                                NdrFcShort( 0x18 ), /* Alpha Stack size/offset = 24 */
#endif
/* 60 */ NdrFcShort( 0x3da ), /* Type Offset=986 */

/* Return value */

/* 62 */ NdrFcShort( 0x70 ), /* Flags: out, return, base type, */
#ifndef _ALPHA_
#ifndef _PPC_
#ifndef _MIPS_
/* 64 */ NdrFcShort( 0x18 ), /* x86 Stack size/offset = 24 */
#else
                                NdrFcShort( 0x1c ), /* MIPS Stack size/offset = 28 */
#endif
#else
                                NdrFcShort( 0x1c ), /* PPC Stack size/offset = 28 */
#endif
#else
                                NdrFcShort( 0x20 ), /* Alpha Stack size/offset = 32 */
#endif
/* 66 */ 0x8, /* FC_LONG */
0x0, /* 0 */

/* Procedure Delivery */

/* 68 */ 0x33, /* FC_AUTO_HANDLE */
0x6c, /* Old Flags: object, Oi2 */
/* 70 */ NdrFcLong( 0x0 ), /* 0 */
/* 74 */ NdrFcShort( 0x5 ), /* 5 */
#ifndef _ALPHA_
#ifndef _PPC_
#ifndef _MIPS_
/* 76 */ NdrFcShort( 0x1c ), /* x86 Stack size/offset = 28 */
#else
                                NdrFcShort( 0x20 ), /* MIPS Stack size/offset = 32 */
#endif
#else
                                NdrFcShort( 0x20 ), /* PPC Stack size/offset = 32 */
#endif
#else
                                NdrFcShort( 0x28 ), /* Alpha Stack size/offset = 40 */
#endif
/* 78 */ NdrFcShort( 0x0 ), /* 0 */
/* 80 */ NdrFcShort( 0x8 ), /* 8 */
/* 82 */ 0x7, /* Oi2 Flags: srv must size, clt must size, has return, */
0x3, /* 3 */
```

# Appendix A - Application Source Code

```
/* Parameter txn_in */

/* 84 */ NdrFcShort( 0x8b ), /* Flags: must size, must free, in, by val, */
#ifdef _ALPHA_
#ifdef _PPC_
#if !defined(_MIPS_)
/* 86 */ NdrFcShort( 0x4 ), /* x86 Stack size/offset = 4 */
#else
NdrFcShort( 0x8 ), /* MIPS Stack size/offset = 8 */
#endif
#endif
#else
NdrFcShort( 0x8 ), /* PPC Stack size/offset = 8 */
#endif
#else
NdrFcShort( 0x8 ), /* Alpha Stack size/offset = 8 */
#endif
/* 88 */ NdrFcShort( 0x3c8 ), /* Type Offset=968 */

/* Parameter txn_out */

/* 90 */ NdrFcShort( 0x4113 ), /* Flags: must size, must free, out, simple ref,
srv alloc size=16 */
#ifdef _ALPHA_
#ifdef _PPC_
#if !defined(_MIPS_)
/* 92 */ NdrFcShort( 0x14 ), /* x86 Stack size/offset = 20 */
#else
NdrFcShort( 0x18 ), /* MIPS Stack size/offset = 24 */
#endif
#endif
#else
NdrFcShort( 0x18 ), /* PPC Stack size/offset = 24 */
#endif
#else
NdrFcShort( 0x18 ), /* Alpha Stack size/offset = 24 */
#endif
/* 94 */ NdrFcShort( 0x3da ), /* Type Offset=986 */

/* Return value */

/* 96 */ NdrFcShort( 0x70 ), /* Flags: out, return, base type, */
#ifdef _ALPHA_
#ifdef _PPC_
#if !defined(_MIPS_)
/* 98 */ NdrFcShort( 0x18 ), /* x86 Stack size/offset = 24 */
#else
NdrFcShort( 0x1c ), /* MIPS Stack size/offset = 28 */
#endif
#endif
#else
NdrFcShort( 0x1c ), /* PPC Stack size/offset = 28 */
#endif
#else
NdrFcShort( 0x20 ), /* Alpha Stack size/offset = 32 */
#endif
/* 100 */ 0x8, /* FC_LONG */
0x0, /* 0 */

/* Procedure StockLevel */

/* 102 */ 0x33, /* FC_AUTO_HANDLE */
0x6c, /* Old Flags: object, Oi2 */
/* 104 */ NdrFcLong( 0x0 ), /* 0 */
/* 108 */ NdrFcShort( 0x6 ), /* 6 */
```

```
#ifndef _ALPHA_
#ifdef _PPC_
#if !defined(_MIPS_)
/* 110 */ NdrFcShort( 0x1c ), /* x86 Stack size/offset = 28 */
#else
NdrFcShort( 0x20 ), /* MIPS Stack size/offset = 32 */
#endif
#endif
#else
NdrFcShort( 0x20 ), /* PPC Stack size/offset = 32 */
#endif
#else
NdrFcShort( 0x28 ), /* Alpha Stack size/offset = 40 */
#endif
/* 112 */ NdrFcShort( 0x0 ), /* 0 */
/* 114 */ NdrFcShort( 0x8 ), /* 8 */
/* 116 */ 0x7, /* Oi2 Flags: srv must size, clt must size, has return, */
0x3, /* 3 */

/* Parameter txn_in */

/* 118 */ NdrFcShort( 0x8b ), /* Flags: must size, must free, in, by val, */
#ifdef _ALPHA_
#ifdef _PPC_
#if !defined(_MIPS_)
/* 120 */ NdrFcShort( 0x4 ), /* x86 Stack size/offset = 4 */
#else
NdrFcShort( 0x8 ), /* MIPS Stack size/offset = 8 */
#endif
#endif
#else
NdrFcShort( 0x8 ), /* PPC Stack size/offset = 8 */
#endif
#else
NdrFcShort( 0x8 ), /* Alpha Stack size/offset = 8 */
#endif
/* 122 */ NdrFcShort( 0x3c8 ), /* Type Offset=968 */

/* Parameter txn_out */

/* 124 */ NdrFcShort( 0x4113 ), /* Flags: must size, must free, out, simple ref,
srv alloc size=16 */
#ifdef _ALPHA_
#ifdef _PPC_
#if !defined(_MIPS_)
/* 126 */ NdrFcShort( 0x14 ), /* x86 Stack size/offset = 20 */
#else
NdrFcShort( 0x18 ), /* MIPS Stack size/offset = 24 */
#endif
#endif
#else
NdrFcShort( 0x18 ), /* PPC Stack size/offset = 24 */
#endif
#else
NdrFcShort( 0x18 ), /* Alpha Stack size/offset = 24 */
#endif
/* 128 */ NdrFcShort( 0x3da ), /* Type Offset=986 */

/* Return value */

/* 130 */ NdrFcShort( 0x70 ), /* Flags: out, return, base type, */
#ifdef _ALPHA_
#ifdef _PPC_
#if !defined(_MIPS_)
/* 132 */ NdrFcShort( 0x18 ), /* x86 Stack size/offset = 24 */
#else
```

# Appendix A - Application Source Code

```

                                NdrFcShort( 0x1c ),/* MIPS Stack size/offset = 28 */
#endif
#else
                                NdrFcShort( 0x1c ),/* PPC Stack size/offset = 28 */
#endif
#else
                                NdrFcShort( 0x20 ),/* Alpha Stack size/offset = 32 */
#endif
/* 134 */ /* 0x8,          /* FC_LONG */
                                0x0,          /* 0 */

        /* Procedure OrderStatus */

/* 136 */ /* 0x33,          /* FC_AUTO_HANDLE */
                                0x6c,          /* Old Flags:  object, Oi2 */
/* 138 */ /* NdrFcLong( 0x0 ), /* 0 */
/* 142 */ /* NdrFcShort( 0x7 ), /* 7 */
#ifdef _ALPHA_
#ifdef _PPC_
#if !defined(_MIPS_)
/* 144 */ /* NdrFcShort( 0x1c ),/* x86 Stack size/offset = 28 */
#else
                                NdrFcShort( 0x20 ),/* MIPS Stack size/offset = 32 */
#endif
#else
                                NdrFcShort( 0x20 ),/* PPC Stack size/offset = 32 */
#endif
#else
                                NdrFcShort( 0x28 ),/* Alpha Stack size/offset = 40 */
#endif
/* 146 */ /* NdrFcShort( 0x0 ), /* 0 */
/* 148 */ /* NdrFcShort( 0x8 ), /* 8 */
/* 150 */ /* 0x7,          /* Oi2 Flags:  srv must size, clt must size, has return, */
                                0x3,          /* 3 */

        /* Parameter txn_in */

/* 152 */ /* NdrFcShort( 0x8b ),/* Flags:  must size, must free, in, by val, */
#ifdef _ALPHA_
#ifdef _PPC_
#if !defined(_MIPS_)
/* 154 */ /* NdrFcShort( 0x4 ), /* x86 Stack size/offset = 4 */
#else
                                NdrFcShort( 0x8 ), /* MIPS Stack size/offset = 8 */
#endif
#else
                                NdrFcShort( 0x8 ), /* PPC Stack size/offset = 8 */
#endif
#else
                                NdrFcShort( 0x8 ), /* Alpha Stack size/offset = 8 */
#endif
/* 156 */ /* NdrFcShort( 0x3c8 ), /* Type Offset=968 */

        /* Parameter txn_out */

/* 158 */ /* NdrFcShort( 0x4113 ), /* Flags:  must size, must free, out, simple ref,
srv alloc size=16 */
#ifdef _ALPHA_
#ifdef _PPC_
#if !defined(_MIPS_)
/* 160 */ /* NdrFcShort( 0x14 ),/* x86 Stack size/offset = 20 */
#else
                                NdrFcShort( 0x18 ),/* MIPS Stack size/offset = 24 */

```

```

#endif
#else
                                NdrFcShort( 0x18 ),/* PPC Stack size/offset = 24 */
#endif
#else
                                NdrFcShort( 0x18 ),/* Alpha Stack size/offset = 24 */
#endif
/* 162 */ /* NdrFcShort( 0x3da ), /* Type Offset=986 */

        /* Return value */

/* 164 */ /* NdrFcShort( 0x70 ),/* Flags:  out, return, base type, */
#ifdef _ALPHA_
#ifdef _PPC_
#if !defined(_MIPS_)
/* 166 */ /* NdrFcShort( 0x18 ),/* x86 Stack size/offset = 24 */
#else
                                NdrFcShort( 0x1c ),/* MIPS Stack size/offset = 28 */
#endif
#else
                                NdrFcShort( 0x1c ),/* PPC Stack size/offset = 28 */
#endif
#else
                                NdrFcShort( 0x20 ),/* Alpha Stack size/offset = 32 */
#endif
/* 168 */ /* 0x8,          /* FC_LONG */
                                0x0,          /* 0 */

        /* Procedure CallSetComplete */

/* 170 */ /* 0x33,          /* FC_AUTO_HANDLE */
                                0x6c,          /* Old Flags:  object, Oi2 */
/* 172 */ /* NdrFcLong( 0x0 ), /* 0 */
/* 176 */ /* NdrFcShort( 0x8 ), /* 8 */
#ifdef _ALPHA_
/* 178 */ /* NdrFcShort( 0x8 ), /* x86, MIPS, PPC Stack size/offset = 8 */
#else
                                NdrFcShort( 0x10 ),/* Alpha Stack size/offset = 16 */
#endif
/* 180 */ /* NdrFcShort( 0x0 ), /* 0 */
/* 182 */ /* NdrFcShort( 0x8 ), /* 8 */
/* 184 */ /* 0x4,          /* Oi2 Flags:  has return, */
                                0x1,          /* 1 */

        /* Return value */

/* 186 */ /* NdrFcShort( 0x70 ),/* Flags:  out, return, base type, */
#ifdef _ALPHA_
/* 188 */ /* NdrFcShort( 0x4 ), /* x86, MIPS, PPC Stack size/offset = 4 */
#else
                                NdrFcShort( 0x8 ), /* Alpha Stack size/offset = 8 */
#endif
/* 190 */ /* 0x8,          /* FC_LONG */
                                0x0,          /* 0 */

                                0x0

        }
};

static const MIDL_TYPE_FORMAT_STRING __MIDL_TypeFormatString =
{
    0,
    {

```

# Appendix A - Application Source Code

```

NdrFcShort( 0x0 ), /* 0 */
/* 2 */
0x12, 0x0, /* FC_UP */
/* 4 */ NdrFcShort( 0x3b0 ), /* Offset= 944 (948) */
/* 6 */
0x2b, /* FC_NON_ENCAPSULATED_UNION */
0x9, /* FC_ULONG */
/* 8 */ 0x7, /* Corr desc: FC_USHORT */
0x0, /* */
/* 10 */ NdrFcShort( 0xffff8 ), /* -8 */
/* 12 */ NdrFcShort( 0x2 ), /* Offset= 2 (14) */
/* 14 */ NdrFcShort( 0x10 ), /* 16 */
/* 16 */ NdrFcShort( 0x2b ), /* 43 */
/* 18 */ NdrFcLong( 0x3 ), /* 3 */
/* 22 */ NdrFcShort( 0x8008 ), /* Simple arm type: FC_LONG */
/* 24 */ NdrFcLong( 0x11 ), /* 17 */
/* 28 */ NdrFcShort( 0x8001 ), /* Simple arm type: FC_BYTE */
/* 30 */ NdrFcLong( 0x2 ), /* 2 */
/* 34 */ NdrFcShort( 0x8006 ), /* Simple arm type: FC_SHORT */
/* 36 */ NdrFcLong( 0x4 ), /* 4 */
/* 40 */ NdrFcShort( 0x800a ), /* Simple arm type: FC_FLOAT */
/* 42 */ NdrFcLong( 0x5 ), /* 5 */
/* 46 */ NdrFcShort( 0x800c ), /* Simple arm type: FC_DOUBLE */
/* 48 */ NdrFcLong( 0xb ), /* 11 */
/* 52 */ NdrFcShort( 0x8006 ), /* Simple arm type: FC_SHORT */
/* 54 */ NdrFcLong( 0xa ), /* 10 */
/* 58 */ NdrFcShort( 0x8008 ), /* Simple arm type: FC_LONG */
/* 60 */ NdrFcLong( 0x6 ), /* 6 */
/* 64 */ NdrFcShort( 0xd6 ), /* Offset= 214 (278) */
/* 66 */ NdrFcLong( 0x7 ), /* 7 */
/* 70 */ NdrFcShort( 0x800c ), /* Simple arm type: FC_DOUBLE */
/* 72 */ NdrFcLong( 0x8 ), /* 8 */
/* 76 */ NdrFcShort( 0xd0 ), /* Offset= 208 (284) */
/* 78 */ NdrFcLong( 0xd ), /* 13 */
/* 82 */ NdrFcShort( 0xe2 ), /* Offset= 226 (308) */
/* 84 */ NdrFcLong( 0x9 ), /* 9 */
/* 88 */ NdrFcShort( 0xee ), /* Offset= 238 (326) */
/* 90 */ NdrFcLong( 0x2000 ), /* 8192 */
/* 94 */ NdrFcShort( 0xfa ), /* Offset= 250 (344) */
/* 96 */ NdrFcLong( 0x24 ), /* 36 */
/* 100 */ NdrFcShort( 0x308 ), /* Offset= 776 (876) */
/* 102 */ NdrFcLong( 0x4024 ), /* 16420 */
/* 106 */ NdrFcShort( 0x302 ), /* Offset= 770 (876) */
/* 108 */ NdrFcLong( 0x4011 ), /* 16401 */
/* 112 */ NdrFcShort( 0x300 ), /* Offset= 768 (880) */
/* 114 */ NdrFcLong( 0x4002 ), /* 16386 */
/* 118 */ NdrFcShort( 0x2fe ), /* Offset= 766 (884) */
/* 120 */ NdrFcLong( 0x4003 ), /* 16387 */
/* 124 */ NdrFcShort( 0x2fc ), /* Offset= 764 (888) */
/* 126 */ NdrFcLong( 0x4004 ), /* 16388 */
/* 130 */ NdrFcShort( 0x2fa ), /* Offset= 762 (892) */
/* 132 */ NdrFcLong( 0x4005 ), /* 16389 */
/* 136 */ NdrFcShort( 0x2f8 ), /* Offset= 760 (896) */
/* 138 */ NdrFcLong( 0x400b ), /* 16395 */
/* 142 */ NdrFcShort( 0x2e6 ), /* Offset= 742 (884) */
/* 144 */ NdrFcLong( 0x400a ), /* 16394 */
/* 148 */ NdrFcShort( 0x2e4 ), /* Offset= 740 (888) */
/* 150 */ NdrFcLong( 0x4006 ), /* 16390 */
/* 154 */ NdrFcShort( 0x2ea ), /* Offset= 746 (900) */
/* 156 */ NdrFcLong( 0x4007 ), /* 16391 */
/* 160 */ NdrFcShort( 0x2e0 ), /* Offset= 736 (896) */
/* 162 */ NdrFcLong( 0x4008 ), /* 16392 */
/* 166 */ NdrFcShort( 0x2e2 ), /* Offset= 738 (904) */

/* 168 */ NdrFcLong( 0x400d ), /* 16397 */
/* 172 */ NdrFcShort( 0x2e0 ), /* Offset= 736 (908) */
/* 174 */ NdrFcLong( 0x4009 ), /* 16393 */
/* 178 */ NdrFcShort( 0x2de ), /* Offset= 734 (912) */
/* 180 */ NdrFcLong( 0x6000 ), /* 24576 */
/* 184 */ NdrFcShort( 0x2dc ), /* Offset= 732 (916) */
/* 186 */ NdrFcLong( 0x400c ), /* 16396 */
/* 190 */ NdrFcShort( 0x2da ), /* Offset= 730 (920) */
/* 192 */ NdrFcLong( 0x10 ), /* 16 */
/* 196 */ NdrFcShort( 0x8002 ), /* Simple arm type: FC_CHAR */
/* 198 */ NdrFcLong( 0x12 ), /* 18 */
/* 202 */ NdrFcShort( 0x8006 ), /* Simple arm type: FC_SHORT */
/* 204 */ NdrFcLong( 0x13 ), /* 19 */
/* 208 */ NdrFcShort( 0x8008 ), /* Simple arm type: FC_LONG */
/* 210 */ NdrFcLong( 0x16 ), /* 22 */
/* 214 */ NdrFcShort( 0x8008 ), /* Simple arm type: FC_LONG */
/* 216 */ NdrFcLong( 0x17 ), /* 23 */
/* 220 */ NdrFcShort( 0x8008 ), /* Simple arm type: FC_LONG */
/* 222 */ NdrFcLong( 0xe ), /* 14 */
/* 226 */ NdrFcShort( 0x2be ), /* Offset= 702 (928) */
/* 228 */ NdrFcLong( 0x400e ), /* 16398 */
/* 232 */ NdrFcShort( 0x2c4 ), /* Offset= 708 (940) */
/* 234 */ NdrFcLong( 0x4010 ), /* 16400 */
/* 238 */ NdrFcShort( 0x2c2 ), /* Offset= 706 (944) */
/* 240 */ NdrFcLong( 0x4012 ), /* 16402 */
/* 244 */ NdrFcShort( 0x280 ), /* Offset= 640 (884) */
/* 246 */ NdrFcLong( 0x4013 ), /* 16403 */
/* 250 */ NdrFcShort( 0x27e ), /* Offset= 638 (888) */
/* 252 */ NdrFcLong( 0x4016 ), /* 16406 */
/* 256 */ NdrFcShort( 0x278 ), /* Offset= 632 (888) */
/* 258 */ NdrFcLong( 0x4017 ), /* 16407 */
/* 262 */ NdrFcShort( 0x272 ), /* Offset= 626 (888) */
/* 264 */ NdrFcLong( 0x0 ), /* 0 */
/* 268 */ NdrFcShort( 0x0 ), /* Offset= 0 (268) */
/* 270 */ NdrFcLong( 0x1 ), /* 1 */
/* 274 */ NdrFcShort( 0x0 ), /* Offset= 0 (274) */
/* 276 */ NdrFcShort( 0xffffffff ), /* Offset= -1 (275) */
/* 278 */
0x15, /* FC_STRUCT */
0x7, /* 7 */
/* 280 */ NdrFcShort( 0x8 ), /* 8 */
/* 282 */ 0xb, /* FC_HYPER */
0x5b, /* FC_END */
/* 284 */
0x12, 0x0, /* FC_UP */
/* 286 */ NdrFcShort( 0xc ), /* Offset= 12 (298) */
/* 288 */
0x1b, /* FC_CARRAY */
0x1, /* 1 */
/* 290 */ NdrFcShort( 0x2 ), /* 2 */
/* 292 */ 0x9, /* Corr desc: FC_ULONG */
0x0, /* */
/* 294 */ NdrFcShort( 0xffffc ), /* -4 */
/* 296 */ 0x6, /* FC_SHORT */
0x5b, /* FC_END */
/* 298 */
0x17, /* FC_CSTRUCT */
0x3, /* 3 */
/* 300 */ NdrFcShort( 0x8 ), /* 8 */
/* 302 */ NdrFcShort( 0xffffffff2 ), /* Offset= -14 (288) */
/* 304 */ 0x8, /* FC_LONG */
0x8, /* FC_LONG */
/* 306 */ 0x5c, /* FC_PAD */
```

# Appendix A - Application Source Code

```
/* 308 */          0x5b,          /* FC_END */
/* 310 */ NdrFcLong( 0x0 ), /* 0 */
/* 314 */ NdrFcShort( 0x0 ), /* 0 */
/* 316 */ NdrFcShort( 0x0 ), /* 0 */
/* 318 */ 0xc0, /* 192 */
/* 320 */ 0x0, /* 0 */
/* 322 */ 0x0, /* 0 */
/* 324 */ 0x0, /* 0 */
/* 326 */          0x46, /* 70 */
/* 328 */ NdrFcLong( 0x20400 ), /* 132096 */
/* 332 */ NdrFcShort( 0x0 ), /* 0 */
/* 334 */ NdrFcShort( 0x0 ), /* 0 */
/* 336 */ 0xc0, /* 192 */
/* 338 */ 0x0, /* 0 */
/* 340 */ 0x0, /* 0 */
/* 342 */ 0x0, /* 0 */
/* 344 */          0x46, /* 70 */
/* 346 */ NdrFcShort( 0x2 ), /* Offset= 2 (348) */
/* 348 */          0x12, 0x10, /* FC_UP [pointer_deref] */
/* 350 */ NdrFcShort( 0x1fc ), /* Offset= 508 (858) */
/* 352 */          0x2a, /* FC_ENCAPSULATED_UNION */
/* 354 */ NdrFcShort( 0x18 ), /* 24 */
/* 356 */ NdrFcShort( 0xa ), /* 10 */
/* 358 */ NdrFcLong( 0x8 ), /* 8 */
/* 362 */ NdrFcShort( 0x58 ), /* Offset= 88 (450) */
/* 364 */ NdrFcLong( 0xd ), /* 13 */
/* 368 */ NdrFcShort( 0x78 ), /* Offset= 120 (488) */
/* 370 */ NdrFcLong( 0x9 ), /* 9 */
/* 374 */ NdrFcShort( 0x94 ), /* Offset= 148 (522) */
/* 376 */ NdrFcLong( 0xc ), /* 12 */
/* 380 */ NdrFcShort( 0xbc ), /* Offset= 188 (568) */
/* 382 */ NdrFcLong( 0x24 ), /* 36 */
/* 386 */ NdrFcShort( 0x114 ), /* Offset= 276 (662) */
/* 388 */ NdrFcLong( 0x800d ), /* 32781 */
/* 392 */ NdrFcShort( 0x130 ), /* Offset= 304 (696) */
/* 394 */ NdrFcLong( 0x10 ), /* 16 */
/* 398 */ NdrFcShort( 0x148 ), /* Offset= 328 (726) */
/* 400 */ NdrFcLong( 0x2 ), /* 2 */
/* 404 */ NdrFcShort( 0x160 ), /* Offset= 352 (756) */
/* 406 */ NdrFcLong( 0x3 ), /* 3 */
/* 410 */ NdrFcShort( 0x178 ), /* Offset= 376 (786) */
/* 412 */ NdrFcLong( 0x14 ), /* 20 */
/* 416 */ NdrFcShort( 0x190 ), /* Offset= 400 (816) */
/* 418 */ NdrFcShort( 0xffffffff ), /* Offset= -1 (417) */
/* 420 */          0x1b, /* FC_CARRY */

/* 422 */ NdrFcShort( 0x4 ), /* 4 */
/* 424 */ 0x19, /* Corr desc: field pointer, FC_ULONG */
/* 426 */ NdrFcShort( 0x0 ), /* 0 */
/* 428 */          0x4b, /* FC_PP */
/* 430 */          0x5c, /* FC_PAD */
/* 432 */ NdrFcShort( 0x4 ), /* 4 */
/* 434 */ NdrFcShort( 0x0 ), /* 0 */
/* 436 */ NdrFcShort( 0x1 ), /* 1 */
/* 438 */ NdrFcShort( 0x0 ), /* 0 */
/* 440 */ NdrFcShort( 0x0 ), /* 0 */
/* 442 */ 0x12, 0x0, /* FC_UP */
/* 444 */ NdrFcShort( 0xffffffff6e ), /* Offset= -146 (298) */
/* 446 */          0x5b, /* FC_END */
/* 448 */ 0x8, /* FC_LONG */
/* 450 */          0x5b, /* FC_PAD */
/* 452 */ NdrFcShort( 0x8 ), /* 8 */
/* 454 */          0x4b, /* FC_PP */
/* 456 */          0x5c, /* FC_PAD */
/* 458 */ NdrFcShort( 0x4 ), /* 4 */
/* 460 */ NdrFcShort( 0x4 ), /* 4 */
/* 462 */ 0x11, 0x0, /* FC_RP */
/* 464 */ NdrFcShort( 0xffffffffd4 ), /* Offset= -44 (420) */
/* 466 */          0x5b, /* FC_END */
/* 468 */ 0x8, /* FC_LONG */
/* 470 */          0x5b, /* FC_PAD */
/* 472 */ NdrFcShort( 0x0 ), /* 0 */
/* 474 */ 0x19, /* Corr desc: field pointer, FC_ULONG */
/* 476 */ NdrFcShort( 0x0 ), /* 0 */
/* 478 */ NdrFcLong( 0xffffffff ), /* -1 */
/* 482 */ 0x4c, /* FC_EMBEDDED_COMPLEX */
/* 484 */ NdrFcShort( 0xffffffff50 ), /* Offset= -176 (308) */
/* 486 */ 0x5c, /* FC_PAD */
/* 488 */          0x5b, /* FC_END */
/* 490 */ NdrFcShort( 0x8 ), /* 8 */
/* 492 */ NdrFcShort( 0x0 ), /* 0 */
/* 494 */ NdrFcShort( 0x6 ), /* Offset= 6 (500) */
```

# Appendix A - Application Source Code

```
/* 496 */ 0x8, /* FC_LONG */
/* 498 */ 0x5c, /* FC_PAD */
/* 500 */
/* 502 */ NdrFcShort( 0xffffffff ), /* Offset= -32 (470) */
/* 504 */
/* 506 */ NdrFcShort( 0x0 ), /* 0 */
/* 508 */ 0x19, /* Corr desc: field pointer, FC_ULONG */
/* 510 */ NdrFcShort( 0x0 ), /* 0 */
/* 512 */ NdrFcLong( 0xffffffff ), /* -1 */
/* 516 */ 0x4c, /* FC_EMBEDDED_COMPLEX */
/* 518 */ NdrFcShort( 0xffffffff40 ), /* Offset= -192 (326) */
/* 520 */ 0x5c, /* FC_PAD */
/* 522 */
/* 524 */ NdrFcShort( 0x8 ), /* 8 */
/* 526 */ NdrFcShort( 0x0 ), /* 0 */
/* 528 */ NdrFcShort( 0x6 ), /* Offset= 6 (534) */
/* 530 */ 0x8, /* FC_LONG */
/* 532 */ 0x5c, /* FC_PAD */
/* 534 */
/* 536 */ NdrFcShort( 0xffffffffe0 ), /* Offset= -32 (504) */
/* 538 */
/* 540 */ NdrFcShort( 0x4 ), /* 4 */
/* 542 */ 0x19, /* Corr desc: field pointer, FC_ULONG */
/* 544 */ NdrFcShort( 0x0 ), /* 0 */
/* 546 */
/* 548 */
/* 550 */ NdrFcShort( 0x4 ), /* 4 */
/* 552 */ NdrFcShort( 0x0 ), /* 0 */
/* 554 */ NdrFcShort( 0x1 ), /* 1 */
/* 556 */ NdrFcShort( 0x0 ), /* 0 */
/* 558 */ NdrFcShort( 0x0 ), /* 0 */
/* 560 */ 0x12, 0x0, /* FC_UP */
/* 562 */ NdrFcShort( 0x182 ), /* Offset= 386 (948) */
/* 564 */
/* 566 */ 0x5c, /* FC_END */
/* 568 */
/* 570 */ NdrFcShort( 0x8 ), /* 8 */

/* 572 */ NdrFcShort( 0x0 ), /* 0 */
/* 574 */ NdrFcShort( 0x6 ), /* Offset= 6 (580) */
/* 576 */ 0x8, /* FC_LONG */
/* 578 */ 0x5c, /* FC_PAD */
/* 580 */
/* 582 */ NdrFcShort( 0xffffffffd4 ), /* Offset= -44 (538) */
/* 584 */
/* 586 */ NdrFcLong( 0x2f ), /* 47 */
/* 590 */ NdrFcShort( 0x0 ), /* 0 */
/* 592 */ NdrFcShort( 0x0 ), /* 0 */
/* 594 */ 0xc0, /* 192 */
/* 596 */ 0x0, /* 0 */
/* 598 */ 0x0, /* 0 */
/* 600 */ 0x0, /* 0 */
/* 602 */
/* 604 */ NdrFcShort( 0x1 ), /* 1 */
/* 606 */ 0x19, /* Corr desc: field pointer, FC_ULONG */
/* 608 */ NdrFcShort( 0x4 ), /* 4 */
/* 610 */ 0x1, /* FC_BYTE */
/* 612 */
/* 614 */ NdrFcShort( 0x1a ), /* FC_BOGUS_STRUCT */
/* 616 */ NdrFcShort( 0x10 ), /* 16 */
/* 618 */ NdrFcShort( 0xa ), /* Offset= 10 (628) */
/* 620 */ 0x8, /* FC_LONG */
/* 622 */ 0x4c, /* FC_EMBEDDED_COMPLEX */
/* 624 */ NdrFcShort( 0xffffffffd8 ), /* Offset= -40 (584) */
/* 626 */ 0x36, /* FC_POINTER */
/* 628 */
/* 630 */ NdrFcShort( 0x12, 0x0, /* FC_UP */
/* 632 */
/* 634 */ NdrFcShort( 0x4 ), /* 4 */
/* 636 */ 0x19, /* Corr desc: field pointer, FC_ULONG */
/* 638 */ NdrFcShort( 0x0 ), /* 0 */
/* 640 */
/* 642 */
/* 644 */ NdrFcShort( 0x4 ), /* 4 */
/* 646 */ NdrFcShort( 0x0 ), /* 0 */
```

# Appendix A - Application Source Code

```
/* 648 */ NdrFcShort( 0x1 ), /* 1 */
/* 650 */ NdrFcShort( 0x0 ), /* 0 */
/* 652 */ NdrFcShort( 0x0 ), /* 0 */
/* 654 */ 0x12, 0x0, /* FC_UP */
/* 656 */ NdrFcShort( 0xffffffffd4 ), /* Offset= -44 (612) */
/* 658 */
                                0x5b, /* FC_END */

                                0x8, /* FC_LONG */
/* 660 */ 0x5c, /* FC_PAD */
                                0x5b, /* FC_END */

/* 662 */
                                0x1a, /* FC_BOGUS_STRUCT */
                                0x3, /* 3 */

/* 664 */ NdrFcShort( 0x8 ), /* 8 */
/* 666 */ NdrFcShort( 0x0 ), /* 0 */
/* 668 */ NdrFcShort( 0x6 ), /* Offset= 6 (674) */
/* 670 */ 0x8, /* FC_LONG */
/* 672 */ 0x5c, /* FC_POINTER */
                                0x36, /* FC_POINTER */
                                0x5b, /* FC_PAD */
/* 674 */
                                0x5b, /* FC_END */

                                0x11, 0x0, /* FC_LP */
/* 676 */ NdrFcShort( 0xffffffffd4 ), /* Offset= -44 (632) */
/* 678 */
                                0x1d, /* FC_SMFARRAY */
                                0x0, /* 0 */

/* 680 */ NdrFcShort( 0x8 ), /* 8 */
/* 682 */ 0x2, /* FC_CHAR */
                                0x5b, /* FC_END */

/* 684 */
                                0x15, /* FC_STRUCT */
                                0x3, /* 3 */

/* 686 */ NdrFcShort( 0x10 ), /* 16 */
/* 688 */ 0x8, /* FC_LONG */
                                0x6, /* FC_SHORT */
/* 690 */ 0x6, /* FC_SHORT */
                                0x4c, /* FC_EMBEDDED_COMPLEX */
/* 692 */ 0x0, /* 0 */
                                NdrFcShort( 0xfffffffff1 ), /* Offset= -15 (678) */
/* 696 */
                                0x5b, /* FC_END */

                                0x1a, /* FC_BOGUS_STRUCT */
                                0x3, /* 3 */

/* 698 */ NdrFcShort( 0x18 ), /* 24 */
/* 700 */ NdrFcShort( 0x0 ), /* 0 */
/* 702 */ NdrFcShort( 0xa ), /* Offset= 10 (712) */
/* 704 */ 0x8, /* FC_LONG */
                                0x36, /* FC_POINTER */
/* 706 */ 0x4c, /* FC_EMBEDDED_COMPLEX */
                                0x0, /* 0 */
/* 708 */ NdrFcShort( 0xfffffffffe8 ), /* Offset= -24 (684) */
/* 710 */ 0x5c, /* FC_PAD */
                                0x5b, /* FC_END */

/* 712 */
                                0x11, 0x0, /* FC_LP */
/* 714 */ NdrFcShort( 0xfffffffff0c ), /* Offset= -244 (470) */
/* 716 */
                                0x1b, /* FC_CARRAY */
                                0x0, /* 0 */

/* 718 */ NdrFcShort( 0x1 ), /* 1 */
/* 720 */ 0x19, /* Corr desc: field pointer, FC_ULONG */
                                0x0, /* */

/* 722 */ NdrFcShort( 0x0 ), /* 0 */
/* 724 */ 0x1, /* FC_BYTE */
                                0x5b, /* FC_END */

/* 726 */
                                0x16, /* FC_PSTRUCT */
                                0x3, /* 3 */

/* 728 */ NdrFcShort( 0x8 ), /* 8 */
/* 730 */
                                0x4b, /* FC_PP */
                                0x5c, /* FC_PAD */

/* 732 */
                                0x46, /* FC_NO_REPEAT */
                                0x5c, /* FC_PAD */

/* 734 */ NdrFcShort( 0x4 ), /* 4 */
/* 736 */ NdrFcShort( 0x4 ), /* 4 */
/* 738 */ 0x12, 0x0, /* FC_UP */
/* 740 */ NdrFcShort( 0xffffffffe8 ), /* Offset= -24 (716) */
/* 742 */
                                0x5b, /* FC_END */

/* 744 */ 0x8, /* FC_LONG */
                                0x8, /* FC_LONG */
                                0x5b, /* FC_END */

/* 746 */
                                0x1b, /* FC_CARRAY */
                                0x1, /* 1 */

/* 748 */ NdrFcShort( 0x2 ), /* 2 */
/* 750 */ 0x19, /* Corr desc: field pointer, FC_ULONG */
                                0x0, /* */

/* 752 */ NdrFcShort( 0x0 ), /* 0 */
/* 754 */ 0x6, /* FC_SHORT */
                                0x5b, /* FC_END */

/* 756 */
                                0x16, /* FC_PSTRUCT */
                                0x3, /* 3 */

/* 758 */ NdrFcShort( 0x8 ), /* 8 */
/* 760 */
                                0x4b, /* FC_PP */
                                0x5c, /* FC_PAD */

/* 762 */
                                0x46, /* FC_NO_REPEAT */
                                0x5c, /* FC_PAD */

/* 764 */ NdrFcShort( 0x4 ), /* 4 */
/* 766 */ NdrFcShort( 0x4 ), /* 4 */
/* 768 */ 0x12, 0x0, /* FC_UP */
/* 770 */ NdrFcShort( 0xffffffffe8 ), /* Offset= -24 (746) */
/* 772 */
                                0x5b, /* FC_END */

/* 774 */ 0x8, /* FC_LONG */
                                0x8, /* FC_LONG */
                                0x5b, /* FC_END */

/* 776 */
                                0x1b, /* FC_CARRAY */
                                0x3, /* 3 */

/* 778 */ NdrFcShort( 0x4 ), /* 4 */
/* 780 */ 0x19, /* Corr desc: field pointer, FC_ULONG */
                                0x0, /* */

/* 782 */ NdrFcShort( 0x0 ), /* 0 */
/* 784 */ 0x8, /* FC_LONG */
                                0x5b, /* FC_END */

/* 786 */
                                0x16, /* FC_PSTRUCT */
```

# Appendix A - Application Source Code

```
/* 788 */ NdrFcShort( 0x8 ), /* 8 */
/* 790 */
                                0x4b, /* FC_PP */
                                0x5c, /* FC_PAD */
/* 792 */
                                0x46, /* FC_NO_REPEAT */
                                0x5c, /* FC_PAD */
/* 794 */ NdrFcShort( 0x4 ), /* 4 */
/* 796 */ NdrFcShort( 0x4 ), /* 4 */
/* 798 */ 0x12, 0x0, /* FC_UP */
/* 800 */ NdrFcShort( 0xffffffffe8 ), /* Offset= -24 (776) */
/* 802 */
                                0x5b, /* FC_END */
/* 804 */ 0x8, /* FC_LONG */
                                0x5b, /* FC_END */
/* 806 */
                                0x1b, /* FC_CARRAY */
                                0x7, /* 7 */
/* 808 */ NdrFcShort( 0x8 ), /* 8 */
/* 810 */ 0x19, /* Corr desc: field pointer, FC_ULONG */
                                0x0, /* */
/* 812 */ NdrFcShort( 0x0 ), /* 0 */
/* 814 */ 0xb, /* FC_HYPER */
                                0x5b, /* FC_END */
/* 816 */
                                0x16, /* FC_PSTRUCT */
                                0x3, /* 3 */
/* 818 */ NdrFcShort( 0x8 ), /* 8 */
/* 820 */
                                0x4b, /* FC_PP */
                                0x5c, /* FC_PAD */
/* 822 */
                                0x46, /* FC_NO_REPEAT */
                                0x5c, /* FC_PAD */
/* 824 */ NdrFcShort( 0x4 ), /* 4 */
/* 826 */ NdrFcShort( 0x4 ), /* 4 */
/* 828 */ 0x12, 0x0, /* FC_UP */
/* 830 */ NdrFcShort( 0xffffffffe8 ), /* Offset= -24 (806) */
/* 832 */
                                0x5b, /* FC_END */
/* 834 */ 0x8, /* FC_LONG */
                                0x5b, /* FC_END */
/* 836 */
                                0x15, /* FC_STRUCT */
                                0x3, /* 3 */
/* 838 */ NdrFcShort( 0x8 ), /* 8 */
/* 840 */ 0x8, /* FC_LONG */
                                0x8, /* FC_LONG */
                                0x5c, /* FC_PAD */
                                0x5b, /* FC_END */
/* 844 */
                                0x1b, /* FC_CARRAY */
                                0x3, /* 3 */
/* 846 */ NdrFcShort( 0x8 ), /* 8 */
/* 848 */ 0x7, /* Corr desc: FC_USHORT */
                                0x0, /* */
/* 850 */ NdrFcShort( 0xfffd8 ), /* -40 */
/* 852 */ 0x4c, /* FC_EMBEDDED_COMPLEX */

                                0x0, /* 0 */
/* 854 */ NdrFcShort( 0xffffffffee ), /* Offset= -18 (836) */
/* 856 */ 0x5c, /* FC_PAD */
                                0x5b, /* FC_END */
/* 858 */
                                0x1a, /* FC_BOGUS_STRUCT */
                                0x3, /* 3 */
/* 860 */ NdrFcShort( 0x28 ), /* 40 */
/* 862 */ NdrFcShort( 0xffffffffee ), /* Offset= -18 (844) */
/* 864 */ NdrFcShort( 0x0 ), /* Offset= 0 (864) */
/* 866 */ 0x6, /* FC_SHORT */
                                0x6, /* FC_SHORT */
/* 868 */ 0x38, /* FC_ALIGNM4 */
                                0x8, /* FC_LONG */
/* 870 */ 0x8, /* FC_LONG */
                                0x4c, /* FC_EMBEDDED_COMPLEX */
/* 872 */ 0x0, /* 0 */
                                NdrFcShort( 0xffffdf7 ), /* Offset= -521 (352) */
                                0x5b, /* FC_END */
/* 876 */
                                0x12, 0x0, /* FC_UP */
/* 878 */ NdrFcShort( 0xfffffef6 ), /* Offset= -266 (612) */
/* 880 */
                                0x12, 0x8, /* FC_UP [simple_pointer] */
/* 882 */ 0x1, /* FC_BYTE */
                                0x5c, /* FC_PAD */
/* 884 */
                                0x12, 0x8, /* FC_UP [simple_pointer] */
/* 886 */ 0x6, /* FC_SHORT */
                                0x5c, /* FC_PAD */
/* 888 */
                                0x12, 0x8, /* FC_UP [simple_pointer] */
/* 890 */ 0x8, /* FC_LONG */
                                0x5c, /* FC_PAD */
/* 892 */
                                0x12, 0x8, /* FC_UP [simple_pointer] */
/* 894 */ 0xa, /* FC_FLOAT */
                                0x5c, /* FC_PAD */
/* 896 */
                                0x12, 0x8, /* FC_UP [simple_pointer] */
/* 898 */ 0xc, /* FC_DOUBLE */
                                0x5c, /* FC_PAD */
/* 900 */
                                0x12, 0x0, /* FC_UP */
/* 902 */ NdrFcShort( 0xfffffd90 ), /* Offset= -624 (278) */
/* 904 */
                                0x12, 0x10, /* FC_UP [pointer_deref] */
/* 906 */ NdrFcShort( 0xfffffd92 ), /* Offset= -622 (284) */
/* 908 */
                                0x12, 0x10, /* FC_UP [pointer_deref] */
/* 910 */ NdrFcShort( 0xfffffda6 ), /* Offset= -602 (308) */
/* 912 */
                                0x12, 0x10, /* FC_UP [pointer_deref] */
/* 914 */ NdrFcShort( 0xfffffdb4 ), /* Offset= -588 (326) */
/* 916 */
                                0x12, 0x10, /* FC_UP [pointer_deref] */
/* 918 */ NdrFcShort( 0xfffffdc2 ), /* Offset= -574 (344) */
/* 920 */
                                0x12, 0x10, /* FC_UP [pointer_deref] */
/* 922 */ NdrFcShort( 0x2 ), /* Offset= 2 (924) */
/* 924 */
                                0x12, 0x0, /* FC_UP */
/* 926 */ NdrFcShort( 0x16 ), /* Offset= 22 (948) */
```

## Appendix A - Application Source Code

```
/* 928 */
    0x15,          /* FC_STRUCT */
    0x7,           /* 7 */
/* 930 */ NdrFcShort( 0x10 ), /* 16 */
/* 932 */ 0x6,        /* FC_SHORT */
    0x1,          /* FC_BYTE */
/* 934 */ 0x1,        /* FC_BYTE */
    0x38,         /* FC_ALIGNM4 */
/* 936 */ 0x8,        /* FC_LONG */
    0x39,         /* FC_ALIGNM8 */
/* 938 */ 0xb,        /* FC_HYPER */
    0x5b,         /* FC_END */
/* 940 */
    0x12, 0x0,    /* FC_UP */
/* 942 */ NdrFcShort( 0xffffffff2 ), /* Offset= -14 (928) */
/* 944 */
    0x12, 0x8,    /* FC_UP [simple_pointer] */
/* 946 */ 0x2,        /* FC_CHAR */
    0x5c,         /* FC_PAD */
/* 948 */
    0x1a,         /* FC_BOGUS_STRUCT */
    0x7,          /* 7 */
/* 950 */ NdrFcShort( 0x20 ), /* 32 */
/* 952 */ NdrFcShort( 0x0 ), /* 0 */
/* 954 */ NdrFcShort( 0x0 ), /* Offset= 0 (954) */
/* 956 */ 0x8,        /* FC_LONG */
    0x8,          /* FC_LONG */
/* 958 */ 0x6,        /* FC_SHORT */
    0x6,          /* FC_SHORT */
/* 960 */ 0x6,        /* FC_SHORT */
    0x6,          /* FC_SHORT */
/* 962 */ 0x4c,       /* FC_EMBEDDED_COMPLEX */
    0x0,          /* 0 */
/* 964 */ NdrFcShort( 0xffffc42 ), /* Offset= -958 (6) */
/* 966 */ 0x5c,       /* FC_PAD */
    0x5b,         /* FC_END */
/* 968 */ 0xb4,       /* FC_USER_MARSHAL */
    0x83,         /* 131 */
/* 970 */ NdrFcShort( 0x0 ), /* 0 */
/* 972 */ NdrFcShort( 0x10 ), /* 16 */
/* 974 */ NdrFcShort( 0x0 ), /* 0 */
/* 976 */ NdrFcShort( 0xffffc32 ), /* Offset= -974 (2) */
/* 978 */
    0x11, 0x4,    /* FC_RP [allocated_on_stack] */
/* 980 */ NdrFcShort( 0x6 ), /* Offset= 6 (986) */
/* 982 */
    0x13, 0x0,    /* FC_OP */
/* 984 */ NdrFcShort( 0xfffffdc ), /* Offset= -36 (948) */
/* 986 */ 0xb4,       /* FC_USER_MARSHAL */
    0x83,         /* 131 */
/* 988 */ NdrFcShort( 0x0 ), /* 0 */
/* 990 */ NdrFcShort( 0x10 ), /* 16 */
/* 992 */ NdrFcShort( 0x0 ), /* 0 */
/* 994 */ NdrFcShort( 0xfffff4 ), /* Offset= -12 (982) */
    0x0
};
const CInterfaceProxyVtbl * _tpcc_com_ps_ProxyVtblList[] =
{
    ( CInterfaceProxyVtbl *) &_ITPCCProxyVtbl,
    0
};
```

```
};
const CInterfaceStubVtbl * _tpcc_com_ps_StubVtblList[] =
{
    ( CInterfaceStubVtbl *) &_ITPCCStubVtbl,
    0
};
PCInterfaceName const _tpcc_com_ps_InterfaceNamesList[] =
{
    "ITPCC",
    0
};
#define _tpcc_com_ps_CHECK_IID(n) IID_GENERIC_CHECK_IID( _tpcc_com_ps, pIID, n)
int __stdcall _tpcc_com_ps_IID_Lookup( const IID * pIID, int * pIndex )
{
    if(!_tpcc_com_ps_CHECK_IID(0))
    {
        *pIndex = 0;
        return 1;
    }
    return 0;
}
const ExtendedProxyFileInfo tpcc_com_ps_ProxyFileInfo =
{
    (PCInterfaceProxyVtblList *) &_tpcc_com_ps_ProxyVtblList,
    (PCInterfaceStubVtblList *) &_tpcc_com_ps_StubVtblList,
    (const PCInterfaceName *) &_tpcc_com_ps_InterfaceNamesList,
    0, /* no delegation
    &_tpcc_com_ps_IID_Lookup,
    1,
    2,
    0, /* table of [async_uuid] interfaces */
    0, /* Filler1 */
    0, /* Filler2 */
    0 /* Filler3 */
};
#endif /* !defined(_M_IA64) && !defined(_M_AXP64) */
#pragma warning( disable: 4049 ) /* more than 64k source lines */
/* this ALWAYS GENERATED file contains the proxy stub code */
/* File created by MIDL compiler version 5.03.0280 */
/* at Sat Apr 08 16:40:10 2000
*/
/* Compiler settings for .\src\tpcc_com_ps.idl:
Oicf (OptLev=12), W1, Zp8, env=Win64 (32b run,appending), ms_ext, c_ext, robust
error checks: allocation ref bounds_check enum stub_data
VC __declspec() decoration level:
__declspec(uuid()), __declspec(selectany), __declspec(novtable)
DECLSPEC_UUID(), MIDL_INTERFACE()
*/
```

## Appendix A - Application Source Code

```
@@MIDL_FILE_HEADING( )

#if defined(_M_IA64) || defined(_M_XPP64)
#define USE_STUBLESS_PROXY

/* verify that the <rpcproxy.h> version is high enough to compile this file*/
#ifndef __REDQ_RPCPROXY_H_VERSION__
#define __REQUIRED_RPCPROXY_H_VERSION__ 475
#endif

#include "rpcproxy.h"
#ifndef __RPCPROXY_H_VERSION__
#error this stub requires an updated version of <rpcproxy.h>
#endif // __RPCPROXY_H_VERSION__

#include "tpcc_com_ps.h"

#define TYPE_FORMAT_STRING_SIZE 979
#define PROC_FORMAT_STRING_SIZE 253
#define TRANSMIT_AS_TABLE_SIZE 0
#define WIRE_MARSHAL_TABLE_SIZE 1

typedef struct _MIDL_TYPE_FORMAT_STRING
{
    short Pad;
    unsigned char Format[ TYPE_FORMAT_STRING_SIZE ];
} MIDL_TYPE_FORMAT_STRING;

typedef struct _MIDL_PROC_FORMAT_STRING
{
    short Pad;
    unsigned char Format[ PROC_FORMAT_STRING_SIZE ];
} MIDL_PROC_FORMAT_STRING;

extern const MIDL_TYPE_FORMAT_STRING __MIDL_TypeFormatString;
extern const MIDL_PROC_FORMAT_STRING __MIDL_ProcFormatString;

/* Standard interface: __MIDL_itf_tpcc_com_ps_0000, ver. 0.0,
GUID={0x00000000,0x0000,0x0000,{0x00,0x00,0x00,0x00,0x00,0x00,0x00,0x00}} */

/* Object interface: IUnknown, ver. 0.0,
GUID={0x00000000,0x0000,0x0000,{0xC0,0x00,0x00,0x00,0x00,0x00,0x00,0x46}} */

/* Object interface: ITPCC, ver. 0.0,
GUID={0xFEE6AA2,0x84B1,0x11d2,{0xBA,0x47,0x00,0xC0,0x4F,0xBF,0xE0,0x8B}} */

extern const MIDL_STUB_DESC Object_StubDesc;

extern const MIDL_SERVER_INFO ITPCC_ServerInfo;

#pragma code_seg(".orpc")
static const unsigned short ITPCC_FormatStringOffsetTable[] =
{
    0,
```

```
44,
88,
132,
176,
220
};

static const MIDL_SERVER_INFO ITPCC_ServerInfo =
{
    &Object_StubDesc,
    0,
    __MIDL_ProcFormatString.Format,
    &ITPCC_FormatStringOffsetTable[-3],
    0,
    0,
    0,
    0
};

static const MIDL_STUBLESS_PROXY_INFO ITPCC_ProxyInfo =
{
    &Object_StubDesc,
    __MIDL_ProcFormatString.Format,
    &ITPCC_FormatStringOffsetTable[-3],
    0,
    0,
    0
};

CINTERFACE_PROXY_VTABLE(9) _ITPCCProxyVtbl =
{
    &ITPCC_ProxyInfo,
    &IID_ITPCC,
    IUnknown_QueryInterface_Proxy,
    IUnknown_AddRef_Proxy,
    IUnknown_Release_Proxy ,
    (void *)-1 /* ITPCC::NewOrder */ ,
    (void *)-1 /* ITPCC::Payment */ ,
    (void *)-1 /* ITPCC::Delivery */ ,
    (void *)-1 /* ITPCC::StockLevel */ ,
    (void *)-1 /* ITPCC::OrderStatus */ ,
    (void *)-1 /* ITPCC::CallSetComplete */
};

const CInterfaceStubVtbl _ITPCCStubVtbl =
{
    &IID_ITPCC,
    &ITPCC_ServerInfo,
    9,
    0, /* pure interpreted */
    CStdStubBuffer_METHODS
};

extern const USER_MARSHAL_ROUTINE_QUADRUPLE UserMarshalRoutines[ WIRE_MARSHAL_TABLE_SIZE
];

static const MIDL_STUB_DESC Object_StubDesc =
{
    0,
    NdrOleAllocate,
    NdrOleFree,
    0,
    0,
```

# Appendix A - Application Source Code

```
0,
0,
0,
__MIDL_TypeFormatString.Format,
1, /* -error bounds_check flag */
0x500002, /* Ndr library version */
0,
0x5030118, /* MIDL Version 5.3.280 */
0,
UserMarshalRoutines,
0, /* notify & notify_flag routine table */
0x1, /* MIDL flag */
0, /* Reserved3 */
0, /* Reserved4 */
0 /* Reserved5 */
};

#pragma data_seg(".rdata")

static const USER_MARSHAL_ROUTINE_QUADRUPLE UserMarshalRoutines[ WIRE_MARSHAL_TABLE_SIZE ] =
{
    {
        VARIANT_UserSize
        ,VARIANT_UserMarshal
        ,VARIANT_UserUnmarshal
        ,VARIANT_UserFree
    }
};

#if !defined(__RPC_WIN64__)
#error Invalid build platform for this stub.
#endif

static const MIDL_PROC_FORMAT_STRING __MIDL_ProcFormatString =
{
    {
        /* Procedure NewOrder */

        0x33, /* FC_AUTO_HANDLE */
        0x6c, /* Old Flags: object, Oi2 */

/* 2 */ NdrFcLong( 0x0 ), /* 0 */
/* 6 */ NdrFcShort( 0x3 ), /* 3 */
#ifdef _ALPHA_
/* 8 */ NdrFcShort( 0x38 ), /* ia64 Stack size/offset = 56 */
#else
NdrFcShort( 0x30 ), /* axp64 Stack size/offset = 48 */
#endif
/* 10 */ NdrFcShort( 0x0 ), /* 0 */
/* 12 */ NdrFcShort( 0x8 ), /* 8 */
/* 14 */ 0x47, /* Oi2 Flags: srv must size, clt must size, has return,
has ext, */
/* 16 */ 0xa, 0x3, /* 3 */
/* 10 */ 0x7, /* 10 */
/* Ext Flags: new corr desc, clt corr
check, srv corr check, */
/* 18 */ NdrFcShort( 0x20 ), /* 32 */
/* 20 */ NdrFcShort( 0x20 ), /* 32 */

```

```
/* 22 */ NdrFcShort( 0x0 ), /* 0 */
/* 24 */ NdrFcShort( 0x0 ), /* 0 */

/* Parameter txn_in */

/* 26 */ NdrFcShort( 0x8b ), /* Flags: must size, must free, in, by val, */
#ifdef _ALPHA_
/* 28 */ NdrFcShort( 0x10 ), /* ia64 Stack size/offset = 16 */
#else
NdrFcShort( 0x8 ), /* axp64 Stack size/offset = 8 */
#endif
/* 30 */ NdrFcShort( 0x3b6 ), /* Type Offset=950 */

/* Parameter txn_out */

/* 32 */ NdrFcShort( 0x6113 ), /* Flags: must size, must free, out, simple ref,
srv alloc size=24 */
#ifdef _ALPHA_
/* 34 */ NdrFcShort( 0x28 ), /* ia64 Stack size/offset = 40 */
#else
NdrFcShort( 0x20 ), /* axp64 Stack size/offset = 32 */
#endif
/* 36 */ NdrFcShort( 0x3c8 ), /* Type Offset=968 */

/* Return value */

/* 38 */ NdrFcShort( 0x70 ), /* Flags: out, return, base type, */
#ifdef _ALPHA_
/* 40 */ NdrFcShort( 0x30 ), /* ia64 Stack size/offset = 48 */
#else
NdrFcShort( 0x28 ), /* axp64 Stack size/offset = 40 */
#endif
/* 42 */ 0x8, /* FC_LONG */
0x0, /* 0 */

/* Procedure Payment */

/* 44 */ 0x33, /* FC_AUTO_HANDLE */
0x6c, /* Old Flags: object, Oi2 */

/* 46 */ NdrFcLong( 0x0 ), /* 0 */
/* 50 */ NdrFcShort( 0x4 ), /* 4 */
#ifdef _ALPHA_
/* 52 */ NdrFcShort( 0x38 ), /* ia64 Stack size/offset = 56 */
#else
NdrFcShort( 0x30 ), /* axp64 Stack size/offset = 48 */
#endif
/* 54 */ NdrFcShort( 0x0 ), /* 0 */
/* 56 */ NdrFcShort( 0x8 ), /* 8 */
/* 58 */ 0x47, /* Oi2 Flags: srv must size, clt must size, has return,
has ext, */
/* 60 */ 0xa, 0x3, /* 3 */
/* 10 */ 0x7, /* 10 */
/* Ext Flags: new corr desc, clt corr
check, srv corr check, */
/* 62 */ NdrFcShort( 0x20 ), /* 32 */
/* 64 */ NdrFcShort( 0x20 ), /* 32 */
/* 66 */ NdrFcShort( 0x0 ), /* 0 */
/* 68 */ NdrFcShort( 0x0 ), /* 0 */

/* Parameter txn_in */

/* 70 */ NdrFcShort( 0x8b ), /* Flags: must size, must free, in, by val, */
#ifdef _ALPHA_

```

# Appendix A - Application Source Code

```
/* 72 */ NdrFcShort( 0x10 ), /* ia64 Stack size/offset = 16 */
#else
                NdrFcShort( 0x8 ), /* axp64 Stack size/offset = 8 */
#endif
/* 74 */ NdrFcShort( 0x3b6 ), /* Type Offset=950 */

        /* Parameter txn_out */

/* 76 */ NdrFcShort( 0x6113 ), /* Flags: must size, must free, out, simple ref,
srv alloc size=24 */
#ifndef _ALPHA_
/* 78 */ NdrFcShort( 0x28 ), /* ia64 Stack size/offset = 40 */
#else
                NdrFcShort( 0x20 ), /* axp64 Stack size/offset = 32 */
#endif
/* 80 */ NdrFcShort( 0x3c8 ), /* Type Offset=968 */

        /* Return value */

/* 82 */ NdrFcShort( 0x70 ), /* Flags: out, return, base type, */
#ifndef _ALPHA_
/* 84 */ NdrFcShort( 0x30 ), /* ia64 Stack size/offset = 48 */
#else
                NdrFcShort( 0x28 ), /* axp64 Stack size/offset = 40 */
#endif
/* 86 */ 0x8, /* FC_LONG */
        0x0, /* 0 */

        /* Procedure Delivery */

/* 88 */ 0x33, /* FC_AUTO_HANDLE */
        0x6c, /* Old Flags: object, Oi2 */
/* 90 */ NdrFcLong( 0x0 ), /* 0 */
/* 94 */ NdrFcShort( 0x5 ), /* 5 */
#ifndef _ALPHA_
/* 96 */ NdrFcShort( 0x38 ), /* ia64 Stack size/offset = 56 */
#else
                NdrFcShort( 0x30 ), /* axp64 Stack size/offset = 48 */
#endif
/* 98 */ NdrFcShort( 0x0 ), /* 0 */
/* 100 */ NdrFcShort( 0x8 ), /* 8 */
/* 102 */ 0x47, /* Oi2 Flags: srv must size, clt must size, has return,
has ext, */
        0x3, /* 3 */
/* 104 */ 0xa, /* 10 */
        0x7, /* Ext Flags: new corr desc, clt corr
check, srv corr check, */
/* 106 */ NdrFcShort( 0x20 ), /* 32 */
/* 108 */ NdrFcShort( 0x20 ), /* 32 */
/* 110 */ NdrFcShort( 0x0 ), /* 0 */
/* 112 */ NdrFcShort( 0x0 ), /* 0 */

        /* Parameter txn_in */

/* 114 */ NdrFcShort( 0x8b ), /* Flags: must size, must free, in, by val, */
#ifndef _ALPHA_
/* 116 */ NdrFcShort( 0x10 ), /* ia64 Stack size/offset = 16 */
#else
                NdrFcShort( 0x8 ), /* axp64 Stack size/offset = 8 */
#endif
/* 118 */ NdrFcShort( 0x3b6 ), /* Type Offset=950 */

        /* Parameter txn_out */
```

```
/* 120 */ NdrFcShort( 0x6113 ), /* Flags: must size, must free, out, simple ref,
srv alloc size=24 */
#ifndef _ALPHA_
/* 122 */ NdrFcShort( 0x28 ), /* ia64 Stack size/offset = 40 */
#else
                NdrFcShort( 0x20 ), /* axp64 Stack size/offset = 32 */
#endif
/* 124 */ NdrFcShort( 0x3c8 ), /* Type Offset=968 */

        /* Return value */

/* 126 */ NdrFcShort( 0x70 ), /* Flags: out, return, base type, */
#ifndef _ALPHA_
/* 128 */ NdrFcShort( 0x30 ), /* ia64 Stack size/offset = 48 */
#else
                NdrFcShort( 0x28 ), /* axp64 Stack size/offset = 40 */
#endif
/* 130 */ 0x8, /* FC_LONG */
        0x0, /* 0 */

        /* Procedure StockLevel */

/* 132 */ 0x33, /* FC_AUTO_HANDLE */
        0x6c, /* Old Flags: object, Oi2 */
/* 134 */ NdrFcLong( 0x0 ), /* 0 */
/* 138 */ NdrFcShort( 0x6 ), /* 6 */
#ifndef _ALPHA_
/* 140 */ NdrFcShort( 0x38 ), /* ia64 Stack size/offset = 56 */
#else
                NdrFcShort( 0x30 ), /* axp64 Stack size/offset = 48 */
#endif
/* 142 */ NdrFcShort( 0x0 ), /* 0 */
/* 144 */ NdrFcShort( 0x8 ), /* 8 */
/* 146 */ 0x47, /* Oi2 Flags: srv must size, clt must size, has return,
has ext, */
        0x3, /* 3 */
/* 148 */ 0xa, /* 10 */
        0x7, /* Ext Flags: new corr desc, clt corr
check, srv corr check, */
/* 150 */ NdrFcShort( 0x20 ), /* 32 */
/* 152 */ NdrFcShort( 0x20 ), /* 32 */
/* 154 */ NdrFcShort( 0x0 ), /* 0 */
/* 156 */ NdrFcShort( 0x0 ), /* 0 */

        /* Parameter txn_in */

/* 158 */ NdrFcShort( 0x8b ), /* Flags: must size, must free, in, by val, */
#ifndef _ALPHA_
/* 160 */ NdrFcShort( 0x10 ), /* ia64 Stack size/offset = 16 */
#else
                NdrFcShort( 0x8 ), /* axp64 Stack size/offset = 8 */
#endif
/* 162 */ NdrFcShort( 0x3b6 ), /* Type Offset=950 */

        /* Parameter txn_out */

/* 164 */ NdrFcShort( 0x6113 ), /* Flags: must size, must free, out, simple ref,
srv alloc size=24 */
#ifndef _ALPHA_
/* 166 */ NdrFcShort( 0x28 ), /* ia64 Stack size/offset = 40 */
#else
                NdrFcShort( 0x20 ), /* axp64 Stack size/offset = 32 */
```

# Appendix A - Application Source Code

```
#endif
/* 168 */ NdrFcShort( 0x3c8 ), /* Type Offset=968 */

/* Return value */

/* 170 */ NdrFcShort( 0x70 ), /* Flags: out, return, base type, */
#ifdef _ALPHA_
/* 172 */ NdrFcShort( 0x30 ), /* ia64 Stack size/offset = 48 */
#else
NdrFcShort( 0x28 ), /* axp64 Stack size/offset = 40 */
#endif
/* 174 */ 0x8, /* FC_LONG */
0x0, /* 0 */

/* Procedure OrderStatus */

/* 176 */ 0x33, /* FC_AUTO_HANDLE */
0x6c, /* Old Flags: object, Oi2 */
/* 178 */ NdrFcLong( 0x0 ), /* 0 */
/* 182 */ NdrFcShort( 0x7 ), /* 7 */
#ifdef _ALPHA_
/* 184 */ NdrFcShort( 0x38 ), /* ia64 Stack size/offset = 56 */
#else
NdrFcShort( 0x30 ), /* axp64 Stack size/offset = 48 */
#endif
/* 186 */ NdrFcShort( 0x0 ), /* 0 */
/* 188 */ NdrFcShort( 0x8 ), /* 8 */
/* 190 */ 0x47, /* Oi2 Flags: srv must size, clt must size, has return,
has ext, */
0x3, /* 3 */
/* 192 */ 0xa, /* 10 */
0x7, /* Ext Flags: new corr desc, clt corr

check, srv corr check, */
/* 194 */ NdrFcShort( 0x20 ), /* 32 */
/* 196 */ NdrFcShort( 0x20 ), /* 32 */
/* 198 */ NdrFcShort( 0x0 ), /* 0 */
/* 200 */ NdrFcShort( 0x0 ), /* 0 */

/* Parameter txn_in */

/* 202 */ NdrFcShort( 0x8b ), /* Flags: must size, must free, in, by val, */
#ifdef _ALPHA_
/* 204 */ NdrFcShort( 0x10 ), /* ia64 Stack size/offset = 16 */
#else
NdrFcShort( 0x8 ), /* axp64 Stack size/offset = 8 */
#endif
/* 206 */ NdrFcShort( 0x3b6 ), /* Type Offset=950 */

/* Parameter txn_out */

/* 208 */ NdrFcShort( 0x6113 ), /* Flags: must size, must free, out, simple ref,
srv alloc size=24 */
#ifdef _ALPHA_
/* 210 */ NdrFcShort( 0x28 ), /* ia64 Stack size/offset = 40 */
#else
NdrFcShort( 0x20 ), /* axp64 Stack size/offset = 32 */
#endif
/* 212 */ NdrFcShort( 0x3c8 ), /* Type Offset=968 */

/* Return value */

/* 214 */ NdrFcShort( 0x70 ), /* Flags: out, return, base type, */
#ifdef _ALPHA_
```

```
/* 216 */ NdrFcShort( 0x30 ), /* ia64 Stack size/offset = 48 */
#else
NdrFcShort( 0x28 ), /* axp64 Stack size/offset = 40 */
#endif
/* 218 */ 0x8, /* FC_LONG */
0x0, /* 0 */

/* Procedure CallSetComplete */

/* 220 */ 0x33, /* FC_AUTO_HANDLE */
0x6c, /* Old Flags: object, Oi2 */
/* 222 */ NdrFcLong( 0x0 ), /* 0 */
/* 226 */ NdrFcShort( 0x8 ), /* 8 */
/* 228 */ NdrFcShort( 0x10 ), /* ia64, axp64 Stack size/offset = 16 */
/* 230 */ NdrFcShort( 0x0 ), /* 0 */
/* 232 */ NdrFcShort( 0x8 ), /* 8 */
/* 234 */ 0x44, /* Oi2 Flags: has return, has ext, */
0x1, /* 1 */
/* 236 */ 0xa, /* 10 */
0x1, /* Ext Flags: new corr desc, */
/* 238 */ NdrFcShort( 0x0 ), /* 0 */
/* 240 */ NdrFcShort( 0x0 ), /* 0 */
/* 242 */ NdrFcShort( 0x0 ), /* 0 */
/* 244 */ NdrFcShort( 0x0 ), /* 0 */

/* Return value */

/* 246 */ NdrFcShort( 0x70 ), /* Flags: out, return, base type, */
/* 248 */ NdrFcShort( 0x8 ), /* ia64, axp64 Stack size/offset = 8 */
/* 250 */ 0x8, /* FC_LONG */
0x0, /* 0 */

0x0

};

static const MIDL_TYPE_FORMAT_STRING __MIDL_TypeFormatString =
{
0,
{
NdrFcShort( 0x0 ), /* 0 */
/* 2 */
0x12, 0x0, /* FC_UP */
/* 4 */ NdrFcShort( 0x39e ), /* Offset= 926 (930) */
/* 6 */
0x2b, /* FC_NON_ENCAPSULATED_UNION */
0x9, /* FC_ULONG */
/* 8 */ 0x7, /* Corr desc: FC_USHORT */
0x0, /* */
/* 10 */ NdrFcShort( 0xffff8 ), /* -8 */
/* 12 */ NdrFcShort( 0x1 ), /* Corr flags: early, */
/* 14 */ NdrFcShort( 0x2 ), /* Offset= 2 (16) */
/* 16 */ NdrFcShort( 0x10 ), /* 16 */
/* 18 */ NdrFcShort( 0x2b ), /* 43 */
/* 20 */ NdrFcLong( 0x3 ), /* 3 */
/* 24 */ NdrFcShort( 0x8008 ), /* Simple arm type: FC_LONG */
/* 26 */ NdrFcLong( 0x11 ), /* 17 */
/* 30 */ NdrFcShort( 0x8001 ), /* Simple arm type: FC_BYTE */
/* 32 */ NdrFcLong( 0x2 ), /* 2 */
/* 36 */ NdrFcShort( 0x8006 ), /* Simple arm type: FC_SHORT */
/* 38 */ NdrFcLong( 0x4 ), /* 4 */
/* 42 */ NdrFcShort( 0x800a ), /* Simple arm type: FC_FLOAT */
/* 44 */ NdrFcLong( 0x5 ), /* 5 */
```

# Appendix A - Application Source Code

```
/* 48 */ NdrFcShort( 0x800c ), /* Simple arm type: FC_DOUBLE */
/* 50 */ NdrFcLong( 0xb ), /* 11 */
/* 54 */ NdrFcShort( 0x8006 ), /* Simple arm type: FC_SHORT */
/* 56 */ NdrFcLong( 0xa ), /* 10 */
/* 60 */ NdrFcShort( 0x8008 ), /* Simple arm type: FC_LONG */
/* 62 */ NdrFcLong( 0x6 ), /* 6 */
/* 66 */ NdrFcShort( 0xd6 ), /* Offset= 214 (280) */
/* 68 */ NdrFcLong( 0x7 ), /* 7 */
/* 72 */ NdrFcShort( 0x800c ), /* Simple arm type: FC_DOUBLE */
/* 74 */ NdrFcLong( 0x8 ), /* 8 */
/* 78 */ NdrFcShort( 0xd0 ), /* Offset= 208 (286) */
/* 80 */ NdrFcLong( 0xd ), /* 13 */
/* 84 */ NdrFcShort( 0xe4 ), /* Offset= 228 (312) */
/* 86 */ NdrFcLong( 0x9 ), /* 9 */
/* 90 */ NdrFcShort( 0xf0 ), /* Offset= 240 (330) */
/* 92 */ NdrFcLong( 0x2000 ), /* 8192 */
/* 96 */ NdrFcShort( 0xfc ), /* Offset= 252 (348) */
/* 98 */ NdrFcLong( 0x24 ), /* 36 */
/* 102 */ NdrFcShort( 0x2f4 ), /* Offset= 756 (858) */
/* 104 */ NdrFcLong( 0x4024 ), /* 16420 */
/* 108 */ NdrFcShort( 0x2ee ), /* Offset= 750 (858) */
/* 110 */ NdrFcLong( 0x4011 ), /* 16401 */
/* 114 */ NdrFcShort( 0x2ec ), /* Offset= 748 (862) */
/* 116 */ NdrFcLong( 0x4002 ), /* 16386 */
/* 120 */ NdrFcShort( 0x2ea ), /* Offset= 746 (866) */
/* 122 */ NdrFcLong( 0x4003 ), /* 16387 */
/* 126 */ NdrFcShort( 0x2e8 ), /* Offset= 744 (870) */
/* 128 */ NdrFcLong( 0x4004 ), /* 16388 */
/* 132 */ NdrFcShort( 0x2e6 ), /* Offset= 742 (874) */
/* 134 */ NdrFcLong( 0x4005 ), /* 16389 */
/* 138 */ NdrFcShort( 0x2e4 ), /* Offset= 740 (878) */
/* 140 */ NdrFcLong( 0x400b ), /* 16395 */
/* 144 */ NdrFcShort( 0x2d2 ), /* Offset= 722 (866) */
/* 146 */ NdrFcLong( 0x400a ), /* 16394 */
/* 150 */ NdrFcShort( 0x2d0 ), /* Offset= 720 (870) */
/* 152 */ NdrFcLong( 0x4006 ), /* 16390 */
/* 156 */ NdrFcShort( 0x2d6 ), /* Offset= 726 (882) */
/* 158 */ NdrFcLong( 0x4007 ), /* 16391 */
/* 162 */ NdrFcShort( 0x2cc ), /* Offset= 716 (878) */
/* 164 */ NdrFcLong( 0x4008 ), /* 16392 */
/* 168 */ NdrFcShort( 0x2ce ), /* Offset= 718 (886) */
/* 170 */ NdrFcLong( 0x400d ), /* 16397 */
/* 174 */ NdrFcShort( 0x2cc ), /* Offset= 716 (890) */
/* 176 */ NdrFcLong( 0x4009 ), /* 16393 */
/* 180 */ NdrFcShort( 0x2ca ), /* Offset= 714 (894) */
/* 182 */ NdrFcLong( 0x6000 ), /* 24576 */
/* 186 */ NdrFcShort( 0x2c8 ), /* Offset= 712 (898) */
/* 188 */ NdrFcLong( 0x400c ), /* 16396 */
/* 192 */ NdrFcShort( 0x2c6 ), /* Offset= 710 (902) */
/* 194 */ NdrFcLong( 0x10 ), /* 16 */
/* 198 */ NdrFcShort( 0x8002 ), /* Simple arm type: FC_CHAR */
/* 200 */ NdrFcLong( 0x12 ), /* 18 */
/* 204 */ NdrFcShort( 0x8006 ), /* Simple arm type: FC_SHORT */
/* 206 */ NdrFcLong( 0x13 ), /* 19 */
/* 210 */ NdrFcShort( 0x8008 ), /* Simple arm type: FC_LONG */
/* 212 */ NdrFcLong( 0x16 ), /* 22 */
/* 216 */ NdrFcShort( 0x8008 ), /* Simple arm type: FC_LONG */
/* 218 */ NdrFcLong( 0x17 ), /* 23 */
/* 222 */ NdrFcShort( 0x8008 ), /* Simple arm type: FC_LONG */
/* 224 */ NdrFcLong( 0xe ), /* 14 */
/* 228 */ NdrFcShort( 0x2aa ), /* Offset= 682 (910) */
/* 230 */ NdrFcLong( 0x400e ), /* 16398 */
/* 234 */ NdrFcShort( 0x2b0 ), /* Offset= 688 (922) */

/* 236 */ NdrFcLong( 0x4010 ), /* 16400 */
/* 240 */ NdrFcShort( 0x2ae ), /* Offset= 686 (926) */
/* 242 */ NdrFcLong( 0x4012 ), /* 16402 */
/* 246 */ NdrFcShort( 0x26c ), /* Offset= 620 (866) */
/* 248 */ NdrFcLong( 0x4013 ), /* 16403 */
/* 252 */ NdrFcShort( 0x26a ), /* Offset= 618 (870) */
/* 254 */ NdrFcLong( 0x4016 ), /* 16406 */
/* 258 */ NdrFcShort( 0x264 ), /* Offset= 612 (870) */
/* 260 */ NdrFcLong( 0x4017 ), /* 16407 */
/* 264 */ NdrFcShort( 0x25e ), /* Offset= 606 (870) */
/* 266 */ NdrFcLong( 0x0 ), /* 0 */
/* 270 */ NdrFcShort( 0x0 ), /* Offset= 0 (270) */
/* 272 */ NdrFcLong( 0x1 ), /* 1 */
/* 276 */ NdrFcShort( 0x0 ), /* Offset= 0 (276) */
/* 278 */ NdrFcShort( 0xffffffff ), /* Offset= -1 (277) */
/* 280 */

/* 282 */ NdrFcShort( 0x8 ), /* 8 */
/* 284 */ 0xb, /* FC_HYPER */
/* 286 */ 0x5b, /* FC_END */

/* 288 */ NdrFcShort( 0xe ), /* Offset= 14 (302) */
/* 290 */

/* 292 */ NdrFcShort( 0x2 ), /* 2 */
/* 294 */ 0x9, /* Corr desc: FC_ULONG */
/* 296 */ NdrFcShort( 0xfffc ), /* -4 */
/* 298 */ NdrFcShort( 0x1 ), /* Corr flags: early, */
/* 300 */ 0x6, /* FC_SHORT */
/* 302 */ 0x5b, /* FC_END */

/* 304 */ NdrFcShort( 0x8 ), /* 8 */
/* 306 */ NdrFcShort( 0xffffffff0 ), /* Offset= -16 (290) */
/* 308 */ 0x8, /* FC_LONG */
/* 310 */ 0x5c, /* FC_PAD */
/* 312 */ 0x5b, /* FC_END */

/* 314 */ NdrFcLong( 0x0 ), /* 0 */
/* 318 */ NdrFcShort( 0x0 ), /* 0 */
/* 320 */ NdrFcShort( 0x0 ), /* 0 */
/* 322 */ 0xc0, /* 192 */
/* 324 */ 0x0, /* 0 */
/* 326 */ 0x0, /* 0 */
/* 328 */ 0x0, /* 0 */
/* 330 */ 0x0, /* 0 */
/* 332 */ NdrFcLong( 0x20400 ), /* FC_IP */
/* 336 */ NdrFcShort( 0x0 ), /* FC_CONSTANT_IID */
/* 338 */ NdrFcShort( 0x0 ), /* 0 */
```

# Appendix A - Application Source Code

```
/* 340 */ 0xc0, /* 192 */
/* 342 */ 0x0, /* 0 */
/* 344 */ 0x0, /* 0 */
/* 346 */ 0x0, /* 0 */
/* 348 */ 0x46, /* 70 */
/* 350 */ NdrFcShort( 0x2 ), /* Offset= 2 (352) */
/* 352 */ 0x12, 0x10, /* FC_UP [pointer_deref] */
/* 354 */ NdrFcShort( 0x1e6 ), /* Offset= 486 (840) */
/* 356 */ 0x2a, /* FC_ENCAPSULATED_UNION */
/* 358 */ 0x89, /* 137 */
/* 360 */ NdrFcShort( 0xa ), /* 10 */
/* 362 */ NdrFcLong( 0x8 ), /* 8 */
/* 366 */ NdrFcShort( 0x50 ), /* Offset= 80 (446) */
/* 368 */ NdrFcLong( 0xd ), /* 13 */
/* 372 */ NdrFcShort( 0x70 ), /* Offset= 112 (484) */
/* 374 */ NdrFcLong( 0x9 ), /* 9 */
/* 378 */ NdrFcShort( 0x90 ), /* Offset= 144 (522) */
/* 380 */ NdrFcLong( 0xc ), /* 12 */
/* 384 */ NdrFcShort( 0xb0 ), /* Offset= 176 (560) */
/* 386 */ NdrFcLong( 0x24 ), /* 36 */
/* 390 */ NdrFcShort( 0x104 ), /* Offset= 260 (650) */
/* 392 */ NdrFcLong( 0x800d ), /* 32781 */
/* 396 */ NdrFcShort( 0x120 ), /* Offset= 288 (684) */
/* 398 */ NdrFcLong( 0x10 ), /* 16 */
/* 402 */ NdrFcShort( 0x13a ), /* Offset= 314 (716) */
/* 404 */ NdrFcLong( 0x2 ), /* 2 */
/* 408 */ NdrFcShort( 0x150 ), /* Offset= 336 (744) */
/* 410 */ NdrFcLong( 0x3 ), /* 3 */
/* 414 */ NdrFcShort( 0x166 ), /* Offset= 358 (772) */
/* 416 */ NdrFcLong( 0x14 ), /* 20 */
/* 420 */ NdrFcShort( 0x17c ), /* Offset= 380 (800) */
/* 422 */ NdrFcShort( 0xffffffff ), /* Offset= -1 (421) */
/* 424 */ 0x21, /* FC_BOGUS_ARRAY */
/* 426 */ 0x3, /* 3 */
/* 428 */ 0x19, /* Corr desc: field pointer, FC_ULONG */
/* 430 */ 0x0, /* 0 */
/* 432 */ NdrFcShort( 0x1 ), /* Corr flags: early, */
/* 434 */ NdrFcLong( 0xffffffff ), /* -1 */
/* 438 */ NdrFcShort( 0x0 ), /* Corr flags: */
/* 440 */ 0x12, 0x0, /* FC_UP */
/* 442 */ NdrFcShort( 0xffffffff74 ), /* Offset= -140 (302) */
/* 444 */ 0x5c, /* FC_PAD */
/* 446 */ 0x5b, /* FC_END */
/* 448 */ 0x1a, /* FC_BOGUS_STRUCT */
/* 450 */ 0x3, /* 3 */
/* 452 */ NdrFcShort( 0x10 ), /* 16 */
/* 454 */ NdrFcShort( 0x0 ), /* 0 */
/* 456 */ NdrFcShort( 0x6 ), /* Offset= 6 (458) */
/* 458 */ 0x8, /* FC_LONG */
/* 460 */ 0x39, /* FC_ALIGNM8 */
/* 462 */ 0x3, /* FC_POINTER */
/* 464 */ 0x5b, /* FC_END */
/* 466 */ 0x11, 0x0, /* FC_RP */
/* 468 */ NdrFcShort( 0xfffffdc ), /* Offset= -36 (424) */
/* 470 */ 0x21, /* FC_BOGUS_ARRAY */
/* 472 */ 0x3, /* 3 */
/* 474 */ NdrFcShort( 0x0 ), /* 0 */
/* 476 */ 0x19, /* Corr desc: field pointer, FC_ULONG */
/* 478 */ 0x0, /* 0 */
/* 480 */ NdrFcShort( 0x0 ), /* 0 */
/* 482 */ NdrFcShort( 0x1 ), /* Corr flags: early, */
/* 484 */ NdrFcLong( 0xffffffff ), /* -1 */
/* 486 */ NdrFcShort( 0x0 ), /* Corr flags: */
/* 488 */ 0x4c, /* FC_EMBEDDED_COMPLEX */
/* 490 */ 0x0, /* 0 */
/* 492 */ NdrFcShort( 0xfffff58 ), /* Offset= -168 (312) */
/* 494 */ 0x5c, /* FC_PAD */
/* 496 */ 0x5b, /* FC_END */
/* 498 */ 0x1a, /* FC_BOGUS_STRUCT */
/* 500 */ 0x3, /* 3 */
/* 502 */ NdrFcShort( 0x10 ), /* 16 */
/* 504 */ NdrFcShort( 0x0 ), /* 0 */
/* 506 */ NdrFcShort( 0x6 ), /* Offset= 6 (496) */
/* 508 */ 0x8, /* FC_LONG */
/* 510 */ 0x39, /* FC_ALIGNM8 */
/* 512 */ 0x3, /* FC_POINTER */
/* 514 */ 0x5b, /* FC_END */
/* 516 */ 0x11, 0x0, /* FC_RP */
/* 518 */ NdrFcShort( 0xfffffdc ), /* Offset= -36 (462) */
/* 520 */ 0x21, /* FC_BOGUS_ARRAY */
/* 522 */ 0x3, /* 3 */
/* 524 */ NdrFcShort( 0x0 ), /* 0 */
/* 526 */ NdrFcShort( 0x1 ), /* Corr flags: early, */
/* 528 */ NdrFcLong( 0xffffffff ), /* -1 */
/* 530 */ NdrFcShort( 0x0 ), /* Corr flags: */
/* 532 */ 0x4c, /* FC_EMBEDDED_COMPLEX */
/* 534 */ 0x0, /* 0 */
/* 536 */ NdrFcShort( 0xfffff44 ), /* Offset= -188 (330) */
/* 538 */ 0x5c, /* FC_PAD */
/* 540 */ 0x5b, /* FC_END */
/* 542 */ 0x1a, /* FC_BOGUS_STRUCT */
/* 544 */ 0x3, /* 3 */
/* 546 */ NdrFcShort( 0x10 ), /* 16 */
/* 548 */ NdrFcShort( 0x0 ), /* 0 */
/* 550 */ NdrFcShort( 0x6 ), /* Offset= 6 (534) */
/* 552 */ 0x8, /* FC_LONG */
/* 554 */ 0x39, /* FC_ALIGNM8 */
/* 556 */ 0x3, /* FC_POINTER */
/* 558 */ 0x5b, /* FC_END */
/* 560 */ 0x11, 0x0, /* FC_RP */
/* 562 */ NdrFcShort( 0xfffffdc ), /* Offset= -36 (500) */
/* 564 */ 0x21, /* FC_BOGUS_ARRAY */
```

# Appendix A - Application Source Code

```
/* 540 */ NdrFcShort( 0x0 ), /* 0 */
/* 542 */ 0x19, /* Corr desc: field pointer, FC_ULONG */
/* 544 */ NdrFcShort( 0x0 ), /* 0 */
/* 546 */ NdrFcShort( 0x1 ), /* Corr flags: early, */
/* 548 */ NdrFcLong( 0xffffffff ), /* -1 */
/* 552 */ NdrFcShort( 0x0 ), /* Corr flags: */
/* 554 */
/* 556 */ NdrFcShort( 0x176 ), /* FC_UP */
/* 558 */ 0x5c, /* FC_PAD */
/* 560 */
/* 562 */ NdrFcShort( 0x10 ), /* 16 */
/* 564 */ NdrFcShort( 0x0 ), /* 0 */
/* 566 */ NdrFcShort( 0x6 ), /* Offset= 6 (572) */
/* 568 */ 0x8, /* FC_LONG */
/* 570 */ 0x36, /* FC_ALIGNM8 */
/* 572 */
/* 574 */ NdrFcShort( 0xfffffdc ), /* FC_RP */
/* 576 */
/* 578 */ NdrFcLong( 0x2f ), /* 47 */
/* 582 */ NdrFcShort( 0x0 ), /* 0 */
/* 584 */ NdrFcShort( 0x0 ), /* 0 */
/* 586 */ 0xc0, /* 192 */
/* 588 */ 0x0, /* 0 */
/* 590 */ 0x0, /* 0 */
/* 592 */ 0x0, /* 0 */
/* 594 */
/* 596 */ NdrFcShort( 0x1 ), /* FC_CARRY */
/* 598 */ 0x19, /* Corr desc: field pointer, FC_ULONG */
/* 600 */ NdrFcShort( 0x4 ), /* 4 */
/* 602 */ NdrFcShort( 0x1 ), /* Corr flags: early, */
/* 604 */ 0x1, /* FC_BYTE */
/* 606 */
/* 608 */ NdrFcShort( 0x18 ), /* 24 */
/* 610 */ NdrFcShort( 0x0 ), /* 0 */
/* 612 */ NdrFcShort( 0xc ), /* Offset= 12 (624) */
/* 614 */ 0x8, /* FC_LONG */
/* 616 */ 0x4c, /* FC_EMBEDDED_COMPLEX */
/* 618 */ NdrFcShort( 0xfffffd6 ), /* Offset= -42 (576) */
/* 620 */ 0x39, /* FC_ALIGNM8 */
/* 622 */ 0x5c, /* FC_POINTER */
```

```
/* 622 */ 0x5c, /* FC_PAD */
/* 624 */
/* 626 */ NdrFcShort( 0xfffffe0 ), /* Offset= -32 (594) */
/* 628 */
/* 630 */ NdrFcShort( 0x0 ), /* 0 */
/* 632 */ 0x19, /* Corr desc: field pointer, FC_ULONG */
/* 634 */ NdrFcShort( 0x0 ), /* 0 */
/* 636 */ NdrFcShort( 0x1 ), /* Corr flags: early, */
/* 638 */ NdrFcLong( 0xffffffff ), /* -1 */
/* 642 */ NdrFcShort( 0x0 ), /* Corr flags: */
/* 644 */
/* 646 */ NdrFcShort( 0xfffffd8 ), /* Offset= -40 (606) */
/* 648 */ 0x5c, /* FC_PAD */
/* 650 */
/* 652 */ NdrFcShort( 0x10 ), /* 16 */
/* 654 */ NdrFcShort( 0x0 ), /* 0 */
/* 656 */ NdrFcShort( 0x6 ), /* Offset= 6 (662) */
/* 658 */ 0x8, /* FC_LONG */
/* 660 */ 0x36, /* FC_ALIGNM8 */
/* 662 */
/* 664 */ NdrFcShort( 0xfffffdc ), /* FC_RP */
/* 666 */
/* 668 */ NdrFcShort( 0x8 ), /* 8 */
/* 670 */ 0x2, /* FC_CHAR */
/* 672 */
/* 674 */ NdrFcShort( 0x10 ), /* 16 */
/* 676 */ 0x8, /* FC_LONG */
/* 678 */ 0x6, /* FC_SHORT */
/* 680 */ 0x0, /* FC_EMBEDDED_COMPLEX */
/* 684 */
/* 686 */ NdrFcShort( 0x20 ), /* 32 */
/* 688 */ NdrFcShort( 0x0 ), /* 0 */
/* 690 */ NdrFcShort( 0xa ), /* Offset= 10 (700) */
/* 692 */ 0x8, /* FC_LONG */
/* 694 */ 0x36, /* FC_POINTER */
/* 696 */ 0x0, /* FC_EMBEDDED_COMPLEX */
/* 698 */ NdrFcShort( 0xfffffe7 ), /* Offset= -25 (672) */
/* 700 */ 0x5b, /* FC_END */
```

# Appendix A - Application Source Code

```
/* 700 */
/* 702 */ NdrFcShort( 0x11, 0x0, /* FC_RP */
/* 704 */ /* Offset= -240 (462) */
/* 706 */ NdrFcShort( 0x1b, /* FC_CARRAY */
/* 708 */ /* 0 */
/* 710 */ NdrFcShort( 0x1, /* 1 */
/* 712 */ /* Corr desc: field pointer, FC_ULONG */
/* 714 */ /* 0 */
/* 716 */ /* Corr flags: early, */
/* 718 */ /* FC_BYTE */
/* 720 */ /* FC_END */
/* 722 */ /* FC_BOGUS_STRUCT */
/* 724 */ /* 3 */
/* 726 */ NdrFcShort( 0x10 ), /* 16 */
/* 728 */ /* 0 */
/* 730 */ NdrFcShort( 0x6 ), /* Offset= 6 (728) */
/* 732 */ /* FC_LONG */
/* 734 */ /* FC_ALIGNM8 */
/* 736 */ /* FC_POINTER */
/* 738 */ /* FC_END */
/* 740 */ NdrFcShort( 0x12, 0x0, /* FC_UP */
/* 742 */ /* Offset= -26 (704) */
/* 744 */ /* FC_CARRAY */
/* 746 */ /* 1 */
/* 748 */ NdrFcShort( 0x2 ), /* 2 */
/* 750 */ /* Corr desc: field pointer, FC_ULONG */
/* 752 */ /* 0 */
/* 754 */ /* Corr flags: early, */
/* 756 */ /* FC_SHORT */
/* 758 */ /* FC_END */
/* 760 */ /* FC_BOGUS_STRUCT */
/* 762 */ /* 3 */
/* 764 */ NdrFcShort( 0x10 ), /* 16 */
/* 766 */ /* 0 */
/* 768 */ NdrFcShort( 0x6 ), /* Offset= 6 (756) */
/* 770 */ /* FC_LONG */
/* 772 */ /* FC_ALIGNM8 */
/* 774 */ /* FC_POINTER */
/* 776 */ /* FC_END */
/* 778 */ /* FC_UP */
/* 780 */ /* Offset= -26 (732) */
/* 782 */ /* FC_CARRAY */
/* 784 */ /* 3 */
/* 786 */ NdrFcShort( 0x4 ), /* 4 */
/* 788 */ /* Corr desc: field pointer, FC_ULONG */
/* 790 */ /* 0 */
/* 792 */ /* Corr flags: early, */
/* 794 */ /* FC_LONG */
/* 796 */ /* FC_END */
/* 798 */ /* FC_BOGUS_STRUCT */
/* 800 */ /* 3 */
/* 802 */ NdrFcShort( 0x11, 0x0, /* FC_RP */
/* 804 */ /* Offset= -240 (462) */
/* 806 */ NdrFcShort( 0x1b, /* FC_CARRAY */
/* 808 */ /* 0 */
/* 810 */ NdrFcShort( 0x1, /* 1 */
/* 812 */ /* Corr desc: field pointer, FC_ULONG */
/* 814 */ /* 0 */
/* 816 */ /* Corr flags: early, */
/* 818 */ /* FC_BYTE */
/* 820 */ /* FC_END */
/* 822 */ /* FC_BOGUS_STRUCT */
/* 824 */ /* 3 */
/* 826 */ NdrFcShort( 0x10 ), /* 16 */
/* 828 */ /* 0 */
/* 830 */ NdrFcShort( 0x6 ), /* Offset= 6 (784) */
/* 832 */ /* FC_LONG */
/* 834 */ /* FC_ALIGNM8 */
/* 836 */ /* FC_POINTER */
/* 838 */ /* FC_END */
/* 840 */ /* FC_UP */
/* 842 */ /* Offset= -26 (760) */
/* 844 */ /* FC_CARRAY */
/* 846 */ /* 7 */
/* 848 */ NdrFcShort( 0x8 ), /* 8 */
/* 850 */ /* Corr desc: field pointer, FC_ULONG */
/* 852 */ /* 0 */
/* 854 */ /* Corr flags: early, */
/* 856 */ /* FC_HYPER */
/* 858 */ /* FC_END */
/* 860 */ /* FC_BOGUS_STRUCT */
/* 862 */ /* 3 */
/* 864 */ NdrFcShort( 0x10 ), /* 16 */
/* 866 */ /* 0 */
/* 868 */ NdrFcShort( 0x0 ), /* 0 */
/* 870 */ /* Offset= 6 (812) */
/* 872 */ /* FC_LONG */
/* 874 */ /* FC_ALIGNM8 */
/* 876 */ /* FC_POINTER */
/* 878 */ /* FC_END */
/* 880 */ /* FC_UP */
/* 882 */ /* Offset= -26 (788) */
/* 884 */ /* FC_STRUCT */
/* 886 */ /* 3 */
/* 888 */ NdrFcShort( 0x8 ), /* 8 */
/* 890 */ /* FC_LONG */
/* 892 */ /* FC_LONG */
/* 894 */ /* FC_PAD */
/* 896 */ /* FC_END */
/* 900 */ /* FC_CARRAY */
/* 902 */ /* 3 */
/* 904 */ NdrFcShort( 0x8 ), /* 8 */
/* 906 */ /* Corr desc: FC_USHORT */
/* 908 */ /* -56 */
/* 910 */ NdrFcShort( 0x1 ), /* Corr flags: early, */
/* 912 */ /* FC_EMBEDDED_COMPLEX */
/* 914 */ /* 0 */
/* 916 */ NdrFcShort( 0xfffffec ), /* Offset= -20 (816) */
/* 918 */ /* FC_PAD */
/* 920 */ /* FC_END */
/* 924 */ /* FC_BOGUS_STRUCT */
/* 926 */ /* 3 */
/* 930 */ NdrFcShort( 0x38 ), /* 56 */
/* 932 */ NdrFcShort( 0xfffffec ), /* Offset= -20 (824) */
/* 934 */ NdrFcShort( 0x0 ), /* Offset= 0 (846) */
/* 936 */ /* FC_SHORT */
/* 938 */ /* FC_SHORT */
/* 940 */ /* FC_ALIGNM4 */
/* 942 */ /* FC_LONG */
```

# Appendix A - Application Source Code

```
/* 852 */ 0x8,          /* FC_LONG */
                                0x4c,          /* FC_EMBEDDED_COMPLEX */
/* 854 */ 0x4,          /* 4 */
                                NdrFcShort( 0xfffffe0d ), /* Offset= -499 (356) */
                                0x5b,          /* FC_END */
/* 858 */
                                0x12, 0x0,      /* FC_UP */
/* 860 */ NdrFcShort( 0xfffff02 ), /* Offset= -254 (606) */
/* 862 */
                                0x12, 0x8,      /* FC_UP [simple_pointer] */
/* 864 */ 0x1,          /* FC_BYTE */
                                0x5c,          /* FC_PAD */
/* 866 */
                                0x12, 0x8,      /* FC_UP [simple_pointer] */
/* 868 */ 0x6,          /* FC_SHORT */
                                0x5c,          /* FC_PAD */
/* 870 */
                                0x12, 0x8,      /* FC_UP [simple_pointer] */
/* 872 */ 0x8,          /* FC_LONG */
                                0x5c,          /* FC_PAD */
/* 874 */
                                0x12, 0x8,      /* FC_UP [simple_pointer] */
/* 876 */ 0xa,          /* FC_FLOAT */
                                0x5c,          /* FC_PAD */
/* 878 */
                                0x12, 0x8,      /* FC_UP [simple_pointer] */
/* 880 */ 0xc,          /* FC_DOUBLE */
                                0x5c,          /* FC_PAD */
/* 882 */
                                0x12, 0x0,      /* FC_UP */
/* 884 */ NdrFcShort( 0xfffffa4 ), /* Offset= -604 (280) */
/* 886 */
                                0x12, 0x10,     /* FC_UP [pointer_deref] */
/* 888 */ NdrFcShort( 0xfffffa6 ), /* Offset= -602 (286) */
/* 890 */
                                0x12, 0x10,     /* FC_UP [pointer_deref] */
/* 892 */ NdrFcShort( 0xfffffdbc ), /* Offset= -580 (312) */
/* 894 */
                                0x12, 0x10,     /* FC_UP [pointer_deref] */
/* 896 */ NdrFcShort( 0xfffffda ), /* Offset= -566 (330) */
/* 898 */
                                0x12, 0x10,     /* FC_UP [pointer_deref] */
/* 900 */ NdrFcShort( 0xffffdd8 ), /* Offset= -552 (348) */
/* 902 */
                                0x12, 0x10,     /* FC_UP [pointer_deref] */
/* 904 */ NdrFcShort( 0x2 ), /* Offset= 2 (906) */
/* 906 */
                                0x12, 0x0,      /* FC_UP */
/* 908 */ NdrFcShort( 0x16 ), /* Offset= 22 (930) */
/* 910 */
                                0x15,          /* FC_STRUCT */
                                0x7,          /* 7 */
/* 912 */ NdrFcShort( 0x10 ), /* 16 */
/* 914 */ 0x6,          /* FC_SHORT */
                                0x1,          /* FC_BYTE */
/* 916 */ 0x1,          /* FC_BYTE */
                                0x38,          /* FC_ALIGNM4 */
/* 918 */ 0x8,          /* FC_LONG */
                                0x39,          /* FC_ALIGNM8 */
/* 920 */ 0xb,          /* FC_HYPER */
                                0x5b,          /* FC_END */
/* 922 */
                                0x12, 0x0,      /* FC_UP */

/* 924 */ NdrFcShort( 0xffffffff2 ), /* Offset= -14 (910) */
/* 926 */
                                0x12, 0x8,      /* FC_UP [simple_pointer] */
/* 928 */ 0x2,          /* FC_CHAR */
                                0x5c,          /* FC_PAD */
/* 930 */
                                0x1a,          /* FC_BOGUS_STRUCT */
                                0x7,          /* 7 */
/* 932 */ NdrFcShort( 0x20 ), /* 32 */
/* 934 */ NdrFcShort( 0x0 ), /* 0 */
/* 936 */ NdrFcShort( 0x0 ), /* Offset= 0 (936) */
/* 938 */ 0x8,          /* FC_LONG */
                                0x8,          /* FC_LONG */
/* 940 */ 0x6,          /* FC_SHORT */
                                0x6,          /* FC_SHORT */
/* 942 */ 0x6,          /* FC_SHORT */
                                0x6,          /* FC_SHORT */
/* 944 */ 0x4c,          /* FC_EMBEDDED_COMPLEX */
                                0x0,          /* 0 */
/* 946 */ NdrFcShort( 0xfffffc54 ), /* Offset= -940 (6) */
/* 948 */ 0x5c,          /* FC_PAD */
                                0x5b,          /* FC_END */
/* 950 */ 0xb4,          /* FC_USER_MARSHAL */
                                0x83,          /* 131 */
/* 952 */ NdrFcShort( 0x0 ), /* 0 */
/* 954 */ NdrFcShort( 0x18 ), /* 24 */
/* 956 */ NdrFcShort( 0x0 ), /* 0 */
/* 958 */ NdrFcShort( 0xfffffc44 ), /* Offset= -956 (2) */
/* 960 */
                                0x11, 0x4,      /* FC_RP [allocated_on_stack] */
/* 962 */ NdrFcShort( 0x6 ), /* Offset= 6 (968) */
/* 964 */
                                0x13, 0x0,      /* FC_OP */
/* 966 */ NdrFcShort( 0xfffffdc ), /* Offset= -36 (930) */
/* 968 */ 0xb4,          /* FC_USER_MARSHAL */
                                0x83,          /* 131 */
/* 970 */ NdrFcShort( 0x0 ), /* 0 */
/* 972 */ NdrFcShort( 0x18 ), /* 24 */
/* 974 */ NdrFcShort( 0x0 ), /* 0 */
/* 976 */ NdrFcShort( 0xfffffff4 ), /* Offset= -12 (964) */
                                0x0
        };

const CInterfaceProxyVtbl * _tpcc_com_ps_ProxyVtblList[] =
{
    ( CInterfaceProxyVtbl *) &ITPCCProxyVtbl,
    0
};

const CInterfaceStubVtbl * _tpcc_com_ps_StubVtblList[] =
{
    ( CInterfaceStubVtbl *) &ITPCCStubVtbl,
    0
};

PCInterfaceName const _tpcc_com_ps_InterfaceNamesList[] =
{
    "ITPCC",
    0
};
```

## Appendix A - Application Source Code

```
#define _tpcc_com_ps_CHECK_IID(n)      IID_GENERIC_CHECK_IID( _tpcc_com_ps, pIID, n)

int __stdcall _tpcc_com_ps_IID_Lookup( const IID * pIID, int * pIndex )
{
    if(!_tpcc_com_ps_CHECK_IID(0))
    {
        *pIndex = 0;
        return 1;
    }

    return 0;
}

const ExtendedProxyFileInfo tpcc_com_ps_ProxyFileInfo =
{
    (PCInterfaceProxyVtblList *) & _tpcc_com_ps_ProxyVtblList,
    (PCInterfaceStubVtblList *) & _tpcc_com_ps_StubVtblList,
    (const PCInterfaceName * ) & _tpcc_com_ps_InterfaceNamesList,
    0, // no delegation
    & _tpcc_com_ps_IID_Lookup,
    1,
    2,
    0, /* table of [async_uuid] interfaces */
    0, /* Filler1 */
    0, /* Filler2 */
    0 /* Filler3 */
};

#endif /* defined(_M_IA64) || defined(_M_AXP64)*/
```

### common/txnlog/include/rtetime.h

```
/* FILE: rtetime.h : header file
 * Copyright 1997 Microsoft Corp., All rights reserved.
 *
 * Authors: Charles Levine, Philip Durr
 *          Microsoft Corp.
 */

#define MAX_JULIAN_TIME      0x7FFFFFFFFFFFFFFF
#define JULIAN_TIME__int64
#define TC_TIME             DWORD
extern "C"
{
    BOOL      InitJulianTime(LPSYSTEMTIME lpInitTime);
    JULIAN_TIME GetJulianTime(void);
    DWORD      MyTickCount(void);
    void      GetJulianAndTC(JULIAN_TIME *pJulian, DWORD *pTC);
    JULIAN_TIME ConvertTo64BitTime(int iYear, int iMonth, int iDay, int iHour, int
iMinute, int iSecond);
    JULIAN_TIME Get64BitTime(LPSYSTEMTIME lpInitTime);
    int      JulianDay( int yr, int mm, int dd );
}
```

```
void      JulianToTime(JULIAN_TIME julianTS, int* yr, int* mm, int* dd, int
*hh, int *mi, int *ss );
void      JulianToCalendar( int day, int* yr, int* mm, int* dd );
}
```

### common/txnlog/include/spinlock.h

```
/*      FILE: SPINLOCK.H
 *
 * Copyright 1997 Microsoft Corp., All rights reserved.
 *
 * Authors: Mike Parkes, Charles Levine, Philip Durr
 *          Microsoft Corp.
 */

#ifdef _INC_Spinlock

const LONG LockClosed      = 1;
const LONG LockOpen       = 0;

/*****
 *
 * Spinlock and Semaphore locking.
 *
 * This class provides a very conservative locking scheme.
 * The assumption behind the code is that locks will be
 * held for a very short time. When a lock is taken a memory
 * location is exchanged. All other threads that want this
 * lock wait by spinning and sometimes sleeping on a semaphore
 * until it becomes free again. The only other choice is not
 * to wait at all and move on to do something else. This
 * module should normally be used in conjunction with cache
 * aligned memory in minimize cache line misses.
 *****/

class Spinlock
{
    // Private data.
    HANDLE      Semaphore;
    volatile LONG m_Spinlock;
    volatile LONG Waiting;

#ifdef _DEBUG
    // Counters for debugging builds.
    volatile LONG TotalLocks;
    volatile LONG TotalSleeps;
    volatile LONG TotalSpins;
    volatile LONG TotalWaits;
#endif

public:
    // Public functions.
    Spinlock( void );
}
```

## Appendix A - Application Source Code

```
inline BOOL ClaimLock( BOOL Wait = TRUE );
inline void ReleaseLock( void );
~Spinlock( void );
// Disabled operations.
Spinlock( const Spinlock & Copy );
void operator=( const Spinlock & Copy );

private:
    // Private functions.
    inline BOOL ClaimSpinlock( volatile LONG *sl );
    void WaitForLock( void );
    void WakeAllSleepers( void );
};

/*****
 *
 * A guaranteed atomic exchange.
 *
 * An attempt is made to claim the Spinlock. This action is
 * guaranteed to be atomic.
 *
 *****/

inline BOOL Spinlock::ClaimSpinlock( volatile LONG *Spinlock )
{
    #ifdef _DEBUG
        InterlockedIncrement( (LPLONG) & TotalLocks );
    #endif
    return ( ((*Spinlock) == LockOpen) && (InterlockedExchange(
(LPLONG)Spinlock, LockClosed) == LockOpen) );
}

/*****
 *
 * Claim the Spinlock.
 *
 * Claim the lock if available else wait or exit.
 *
 *****/

inline BOOL Spinlock::ClaimLock( BOOL Wait )
{
    if ( ! ClaimSpinlock( (volatile LONG*) & m_Spinlock ) )
    {
        if ( Wait )
            WaitForLock();
        return Wait;
    }
    return TRUE;
}

/*****
 *
 * Release the Spinlock.
 *
 * Release the lock and if needed wakeup any sleepers.
 *
 *****/

inline void Spinlock::ReleaseLock( void )
{
    m_Spinlock = LockOpen;
}
```

```
        if ( Waiting > 0 )
            WakeAllSleepers();
    }

#define _INC_Spinlock

#endif
```

### common/txnlog/include/txnlog.h

```
/* FILE: TXNLOG.H
 * Microsoft TPC-C Kit Ver. 4.10.000
 *
 * NOTE: this file is RTE specific and should not be
 * included
 * in Full Disclosure Reports.
 *
 * Copyright Microsoft, 1999
 *
 * PURPOSE: Structure definitions for logging delivery txn completion stats.
 * Contact: Charles Levine (clevine@microsoft.com)
 */

typedef struct _TXN_NEWORDER
{
    BYTE OL_Count; //range 0 to 31
    BYTE OL_Remote_Count; //range 0 to 31
    WORD c_id;
    int o_id;
} TXN_NEWORDER;

typedef struct _TXN_PAYMENT
{
    BYTE CustByName;
    BYTE IsRemote;
} TXN_PAYMENT;

typedef struct _TXN_ORDERSTATUS
{
    BYTE CustByName;
} TXN_ORDERSTATUS;

typedef union _TXN_DETAILS
{
    TXN_NEWORDER NewOrder;
    TXN_PAYMENT Payment;
    TXN_ORDERSTATUS OrderStatus;
} TXN_DETAILS;

// Common header for all records in txn log. The TxnType field is
// a switch which identifies the particular variant.
#define TXN_REC_TYPE_CONTROL 1 //
```

# Appendix A - Application Source Code

```
#define TXN_REC_TYPE_TPCC          2          // replaces
TRANSACTION_TYPE_TPCC
#define TXN_REC_TYPE_TPCC_DELIV_DEF  3

typedef struct _TXN_RECORD_HEADER
{
    JULIAN_TIME    TxnStartT0;          // start of txn
    BYTE    TxnType;          // one of TXN_REC_TYPE_*
    BYTE    TxnSubType;          // depends on
TxnType
} TXN_RECORD_HEADER, *PTXN_RECORD_HEADER;

typedef struct _TXN_RECORD_CONTROL
{
    // common header; must exactly match TXN_RECORD_HEADER
    JULIAN_TIME    TxnStartT0;          // start of txn
    BYTE    TxnType;          // = TXN_REC_TYPE_CONTROL
    BYTE    TxnSubType;          // depends on
TxnType

    // end of common header

    DWORD    Len;          // number of bytes
after this field
} TXN_RECORD_CONTROL, *PTXN_RECORD_CONTROL;

// TPC-C Txn Record Layout:
//
// 'TxnStartT0' is a Julian timestamp corresponding to the moment the
// txn is sent to the SUT, i.e., beginning of response time. Deltas
// are in milliseconds. Note that if RTDelay > 0, then the txn was
// delayed by this amount. The delay occurs at the beginning of the
// response time. So if RTDelay > 0, then the txn was actually sent
// at TxnStartT0 + RTDelay.
//
// Graphically:
//
// time -->
//
// |--- Menu ---|-- Keying --|-- Response --|--- Think ---|
// <- DeltaT1 -> <- DeltaT2 -> <- DeltaT4 -> <- DeltaT3 ->
//
//           ^
//           ^ TxnStartT0
//
// RTDelay is the amount of response time delay included in DeltaT4.
// RTDelay is recorded per txn because this value can be changed on
// the fly, and so may vary from txn to txn.
//
// TxnStatus is the txn completion code. It is used to indicate errors.
// For example, in the New Order txn, 1% of txns abort. TxnStatus will
// reflect this.

typedef struct _TXN_RECORD_TPCC
{
    // common header; must exactly match TXN_RECORD_HEADER
    JULIAN_TIME    TxnStartT0;          // start of txn
    BYTE    TxnType;          // = TXN_REC_TYPE_TPCC
    BYTE    TxnSubType;          // depends on
TxnType

    // end of common header

    int    DeltaT1;          // menu time (ms)
```

```
int    DeltaT2;          // keying time (ms)
int    DeltaT3;          // think time (ms)
int    DeltaT4;          // response time (ms)
int    RTDelay;          // response time delay (ms)
int    TxnError;          // error code providing more
detail for TxnStatus
WORD    w_id;          // warehouse ID
BYTE    d_id;          // assigned district ID for
this thread
BYTE    d_id_ThisTxn;          // district ID chosen for this
particular
BYTE    TxnStatus;          // completion status for txn
to indicate errors
BYTE    reserved;          // for word alignment
    TXN_DETAILS    TxnDetails;          //
} TXN_RECORD_TPCC, *PTXN_RECORD_TPCC;

// TPC-C Deferred Delivery Txn Record Layout:
//
// Incorporating delivery transaction information into the above
// structure would increase the size of TXN_DETAILS from 8 to 42 bytes.
// Hence, we store delivery transaction details in a separate structure.
//
typedef struct _TXN_RECORD_TPCC_DELIV_DEF
{
    // common header; must exactly match TXN_RECORD_HEADER
    JULIAN_TIME    TxnStartT0;          // start of txn
    BYTE    TxnType;          // =
TXN_REC_TYPE_TPCC_DELIV_DEF
    BYTE    TxnSubType;          // = 0
// end of common header

    int    DeltaT4;          // response time (ms)
    int    DeltaTxnExec;          // execution time (ms)
    WORD    w_id;          // warehouse ID
    BYTE    TxnStatus;          // completion status for txn
to indicate errors
    BYTE    reserved;          // for word alignment
    short    o_carrier_id;          // carrier id
    long    o_id[10];          // returned delivery transaction ids
} TXN_RECORD_TPCC_DELIV_DEF, *PTXN_RECORD_TPCC_DELIV_DEF;

#define TXN_LOG_VERSION          1
#define TXN_DATA_START          4096          // offset in log file where
log records start
#define TXN_LOG_EYE_CATCHER "BC"          // signature bytes at the start of log
file

////////////////////////////////////
// The transaction log has a header as the first 4K block.
//
typedef struct _TXN_LOG_HEADER
{
    char    EyeCatcher[2];          // signature bytes;
should always be "BC"
    int    LogVersion;
// set to TXN_LOG_VERSION
    JULIAN_TIME    BeginTxnTS;          //
timestamp of first (lowest) txn start
```



## Appendix A - Application Source Code

---

```
        inline BOOL IsSorted(void) { return bLogSorted; };
        inline JULIAN_TIME BeginTS(void) { return BeginTxnTS; };
        inline JULIAN_TIME EndTS(void) { return EndTxnTS; };
        inline int RecordCount(void) { return iRecCount; };
};

class CTXNLOG_ERR : public CBaseErr
{
    public:
        enum CTPCC_DBLIB_ERRS
        {
            ERR_BAD_FILE_FORMAT = 1,    // "File format is invalid."
            ERR_UNKNOWN_LOG_VERSION,    // "Log file version is
unknown."
            ERR_BROKEN_LOG_FILE,        // "Log file is
broken."
            ERR_LOG_NOT_SORTED,         // "Log file is not
sorted"
            ERR_INVALID_TIME_SEQ,       // "Internal Error:
Record Time Sequence invalid."
        };

        CTXNLOG_ERR( int iErr ) { m_errno = iErr; };

        int m_errno;

        int ErrorType() {return ERR_TYPE_TXNLOG;};
        int ErrorNum() {return m_errno;};

        // TODO: need to complete...
        char *ErrorText() {return "";};
};
```

# Appendix B - Database Design

## Appendix B - Database Design

### Build Scripts

#### setup.cmd

```
ECHO OFF

@ECHO *****
@ECHO *
@ECHO * Microsoft TPC-C Benchmark Kit Ver. 4.01
@ECHO *
@ECHO *****

if '%1'==' ' goto usage
if '%2'==' ' goto usage
if '%3'==' ' goto usage
if '%4'==' ' goto usage
if not '%5'==' ' if not '%5' == 'scaled' goto usage

::Cleanup any old .err files
@if exist logs\*.err del logs\*.err
>nul

if '%3'=='full' goto start
if '%3'=='builddb' goto builddb
if '%3'=='objects' goto objects
if '%3'=='bulkload' goto bulkload
if '%3'=='objectsfull' goto objects
if '%3'=='bulkloadfull' goto bulkload
if '%3'=='backup' goto backup
goto usage

:start
:: Cleanup the logs directory...
@if exist logs\version.log del logs\version.log >nul
@if exist logs\db.log del logs\db.log >nul
@if exist logs\objects.log del logs\objects.log >nul
@if exist logs\objects.log del logs\objects.log >nul
@if exist logs\bulkload.log del logs\bulkload.log >nul
@if exist logs\backup.log del logs\backup.log >nul

isql -Usa -P -S%1 -Q"select @@version"
logs\version.log >
isql -Usa -P -S%1 -Q"select getdate()"
logs\version.log >>

:builddb
@if exist logs\db.log del logs\db.log >nul
@ECHO Building database files and database...
isql -Usa -P -S%1 -e < scripts\%2.war\%4\createdb.sql
logs\db.log >
@ECHO Database build complete.
if '%3'=='full' goto objects
```

```
goto end

:objects
@if exist logs\objects.log del logs\objects.log >nul
@ECHO Creating database objects...
isql -Usa -P -S%1 -e < scripts\ddl\%4\tables.sql > logs\objects.log
isql -Usa -P -S%1 -e < scripts\dml\%4\neword.sql >> logs\objects.log
isql -Usa -P -S%1 -e < scripts\dml\%4\payment.sql >> logs\objects.log
isql -Usa -P -S%1 -e < scripts\dml\%4\ordstat.sql >> logs\objects.log
isql -Usa -P -S%1 -e < scripts\dml\%4\delivery.sql >>
logs\objects.log
isql -Usa -P -S%1 -e < scripts\dml\%4\stocklev.sql >>
logs\objects.log
@ECHO Database object creation complete.
if '%3'=='full' goto bulkload
if '%3'=='objectsfull' goto bulkload
goto end

:bulkload
@if exist logs\bulkload.log del logs\bulkload.log >nul
@ECHO Beginning data load and index creation...
isql -Usa -P -S%1 -e < scripts\utility\%4\dbopt1.sql >>
logs\objects.log
if '%4'=='mssql70' goto odbc
if '%4'=='mssql65' goto dblink
goto usage
:dblib
if '%5'==' ' loader\%4\bin\tpccldr -S%1 -W%2 -flogs\bulkload.log -dscrip\ddl\%4 -c0
if '%5'=='normal' loader\%4\bin\tpccldr -S%1 -W%2 -flogs\bulkload.log -dscrip\ddl\%4 -c0
if '%5'=='scaled' loader\%4\bin\tpccldr -S%1 -W%2 -flogs\bulkload.log -dscrip\ddl\%4 -c1
goto bulkloaddone
:odbc
if '%5'==' ' loader\%4\bin\tpccldr -S%1 -W%2 -flogs\bulkload.log -dscrip\ddl\%4 -c0
if '%5'=='normal' loader\%4\bin\tpccldr -S%1 -W%2 -flogs\bulkload.log -dscrip\ddl\%4 -c0
if '%5'=='scaled' loader\%4\bin\tpccldr -S%1 -W%2 -flogs\bulkload.log -dscrip\ddl\%4 -c1
goto bulkloaddone
:bulkloaddone
isql -Usa -P -S%1 -e < scripts\utility\%4\dbopt2.sql >>
logs\bulkload.log
@ECHO Data load and index creation complete.
if '%3'=='full' goto backup
if '%3'=='objectsfull' goto backup
if '%3'=='bulkloadfull' goto backup
goto end

:backup
@if exist logs\backup.log del logs\backup.log >nul
@ECHO Backing up database...
isql -Usa -P -S%1 -e < scripts\%2.war\%4\backup.sql >
logs\backup.log
@ECHO Database backup complete.
if '%3'=='full' goto verifyload
if '%3'=='objectsfull' goto verifyload
if '%3'=='bulkloadfull' goto verifyload
goto complete

:verifyload
@if exist logs\verifyload.log del logs\verifyload.log >nul
@Echo Verifying TPC-C database load...
```

## Appendix B - Database Design

```
isql -Usa -P -S%1 < scripts\utility\%4\verifytpccload.sql >
logs\verifyload.log
@ECHO Check logs\verifyload.log to verify database load.

:complete
@ECHO *****
@ECHO *
@ECHO * Full TPC-C build complete. Check logs directory for setup errors. *
@ECHO *
@ECHO *****
goto end

:usage
@ECHO *****
@ECHO *
@ECHO * The TPC-C setup command file requires the following parameters: *
@ECHO *
@ECHO * setup SERVER NUMWAR BLDOPT VERSION DBTYPE *
@ECHO *
@ECHO * SERVER = machine name of server (use "" for local server) *
@ECHO * NUMWAR = number of warehouses *
@ECHO * BLDOPT = full, bulddb, objects, objectsfull, bulkload, *
@ECHO * bulkloadfull, or backup *
@ECHO * VERSION = mssql65 or mssql70 *
@ECHO * DBTYPE = normal or scaled *
@ECHO *
@ECHO * Note #1: the BLDOPT and VERSION parameters are case sensitive. *
@ECHO *
@ECHO * Note #2: the DBTYPE is optional. If no DBTYPE is specified, SETUP *
@ECHO * will default to NORMAL. *
@ECHO *
@ECHO * Example: *
@ECHO *
@ECHO * The following command would be used to build a complete 200 *
@ECHO * warehouse database on SQL Server 7.0 running on server \\myserver. *
@ECHO *
@ECHO * SETUP myserver 200 full mssql70 *
@ECHO *
@ECHO * Note, this command file does a backup of the database by default *
@ECHO * after the database build process is complete. If you do not wish *
@ECHO * to make a backup (strongly discouraged), you must edit this file *
@ECHO * and comment that section out. Also, if you need to run the dbcheck *
@ECHO * and the dbtables scripts on the fresh database load for an audit, *
@ECHO * you must either run them manually or edit this file to include them. *
@ECHO *
@ECHO *****

:end

echo on
```

### createdb.sql

```
-- File: CREATEDB.SQL
-- Microsoft TPC-C Benchmark Kit Ver. 4.21
-- Copyright Microsoft, 1999, 2000
-- Purpose: Creates tpcc database and backup files
```

```
use master
```

```
go

-- Create temporary table for timing
if exists ( select name from sysobjects where name = 'tpcc_timer' )
drop table tpcc_timer
go

create table tpcc_timer
(
start_date char(30),
end_date char(30)
)

insert into tpcc_timer values (0,0)
go

-- Store starting time
update tpcc_timer
set start_date = (select convert(char(30), getdate(),9))
go

-- create main database files

CREATE DATABASE tpcc
ON PRIMARY
(
NAME = MSSQL70_tpcc_root,
FILENAME = "C:\MSSQL70_tpcc_root.mdf",
SIZE = 8MB,
FILEGROWTH = 0),
FILEGROUP MSSQL70_misc_fg
(
NAME = MSSQL70_misc1,
FILENAME = "F:",
SIZE = 16560MB,
FILEGROWTH = 0),
(
NAME = MSSQL70_misc2,
FILENAME = "H:",
SIZE = 16560MB,
FILEGROWTH = 0),
(
NAME = MSSQL70_misc3,
FILENAME = "J:",
SIZE = 16560MB,
FILEGROWTH = 0),
(
NAME = MSSQL70_misc4,
FILENAME = "L:",
SIZE = 16560MB,
FILEGROWTH = 0),
(
NAME = MSSQL70_misc5,
FILENAME = "N:",
SIZE = 16560MB,
FILEGROWTH = 0),
FILEGROUP MSSQL70_cs_fg
(
NAME = MSSQL70_cs1,
FILENAME = "E:",
SIZE = 30000MB,
FILEGROWTH = 0),
(
NAME = MSSQL70_cs2,
FILENAME = "G:",
SIZE = 30000MB,
FILEGROWTH = 0),
(
NAME = MSSQL70_cs3,
FILENAME = "I:",
```

## Appendix B - Database Design

```
        SIZE                = 30000MB,
        FILEGROWTH          = 0),
(
    NAME                    = MSSQL70_cs4,
    FILENAME = "K:",
    SIZE                    = 30000MB,
    FILEGROWTH              = 0),
(
    NAME                    = MSSQL70_cs5,
    FILENAME = "M:",
    SIZE                    = 30000MB,
    FILEGROWTH              = 0)
LOG ON
(
    NAME                    =MSSQL70_tpccv3_log,
    FILENAME ="S:",
    SIZE                    =58200MB,
    FILEGROWTH              =0)
go

-- Store ending time
update tpcc_timer
set end_date = (select convert(char(30), getdate()),9)
go

select "Elapsed time (in seconds): ", datediff(second,(select start_date from
tpcc_timer),(select end_date from tpcc_timer))

-- remove temporary table
if exists ( select name from sysobjects where name = 'tpcc_timer' )
drop table tpcc_timer
go
```

### tables.sql

```
-- File: TABLES.SQL
-- Microsoft TPC-C Benchmark Kit Ver. 4.00
-- Copyright Microsoft, 1996
-- Purpose: Creates TPC-C tables

use tpcc
go

if exists ( select name from sysobjects where name = 'warehouse' )
drop table warehouse
go
create table warehouse
(
    w_id                smallint,
    w_name              char(10),
    w_street_1          char(20),
    w_street_2          char(20),
    w_city              char(20),
    w_state             char(2),
    w_zip              char(9),
    w_tax              numeric(4,4),
    w_ytd              numeric(12,2)
) on MSSQL70_misc_fg
go
```

```
if exists ( select name from sysobjects where name = 'district' )
drop table district
go
create table district
(
    d_id                tinyint,
    d_w_id              smallint,
    d_name              char(10),
    d_street_1          char(20),
    d_street_2          char(20),
    d_city              char(20),
    d_state             char(2),
    d_zip              char(9),
    d_tax              numeric(4,4),
    d_ytd              numeric(12,2),
    d_next_o_id        int
) on MSSQL70_misc_fg
go

if exists ( select name from sysobjects where name = 'customer' )
drop table customer
go
create table customer
(
    c_id                int,
    c_d_id              tinyint,
    c_w_id              smallint,
    c_first             char(16),
    c_middle            char(2),
    c_last              char(16),
    c_street_1          char(20),
    c_street_2          char(20),
    c_city              char(20),
    c_state             char(2),
    c_zip              char(9),
    c_phone             char(16),
    c_since             datetime,
    c_credit            char(2),
    c_credit_lim        numeric(12,2),
    c_discount          numeric(4,4),
    c_balance           numeric(12,2),
    c_ytd_payment       numeric(12,2),
    c_payment_cnt       smallint,
    c_delivery_cnt       smallint,
    c_data              char(500)
) on MSSQL70_cs_fg
go

if exists ( select name from sysobjects where name = 'history' )
drop table history
go
create table history
(
    h_c_id              int,
    h_c_d_id            tinyint,
    h_c_w_id            smallint,
    h_d_id              tinyint,
    h_w_id              smallint,
    h_date              datetime,
    h_amount            numeric(6,2),
    h_data              char(24)
) on MSSQL70_misc_fg
```

## Appendix B - Database Design

```
go

if exists ( select name from sysobjects where name = 'new_order' )
    drop table new_order
go
create table new_order
(
    no_o_id          int,
    no_d_id          tinyint,
    no_w_id          smallint
) on MSSQL70_misc_fg
go

if exists ( select name from sysobjects where name = 'orders' )
    drop table orders
go
create table orders
(
    o_id            int,
    o_d_id          tinyint,
    o_w_id          smallint,
    o_c_id          int,
    o_entry_d       datetime,
    o_carrier_id    tinyint,
    o_ol_cnt        tinyint,
    o_all_local     tinyint
) on MSSQL70_misc_fg
go

if exists ( select name from sysobjects where name = 'order_line' )
    drop table order_line
go
create table order_line
(
    ol_o_id          int,
    ol_d_id          tinyint,
    ol_w_id          smallint,
    ol_number        tinyint,
    ol_i_id          int,
    ol_supply_w_id   smallint,
    ol_delivery_d    datetime,
    ol_quantity      smallint,
    ol_amount        numeric(6,2),
    ol_dist_info     char(24)
) on MSSQL70_misc_fg
go

if exists ( select name from sysobjects where name = 'item' )
    drop table item
go
create table item
(
    i_id            int,
    i_im_id         int,
    i_name          char(24),
    i_price         numeric(5,2),
    i_data          char(50)
) on MSSQL70_misc_fg
go

if exists ( select name from sysobjects where name = 'stock' )
    drop table stock
go
```

```
create table stock
(
    s_i_id          int,
    s_w_id          smallint,
    s_quantity      smallint,
    s_dist_01       char(24),
    s_dist_02       char(24),
    s_dist_03       char(24),
    s_dist_04       char(24),
    s_dist_05       char(24),
    s_dist_06       char(24),
    s_dist_07       char(24),
    s_dist_08       char(24),
    s_dist_09       char(24),
    s_dist_10       char(24),
    s_ytd           int,
    s_order_cnt     smallint,
    s_remote_cnt    smallint,
    s_data          char(50)
) on MSSQL70_cs_fg
go
```

### idxcuscl.sql

```
-- File:      IDXCUSCL.SQL
--           Microsoft TPC-C Benchmark Kit Ver. 4.00
--           Copyright Microsoft, 1996
-- Purpose:   Creates clustered index on customer table

use tpcc
go

declare @startdate datetime
declare @enddate datetime
select @startdate = getdate()
select "Start date:", convert(varchar(30),@startdate,9)

if exists ( select name from sysindexes where name = 'customer_c1' )
    drop index customer.customer_c1

create unique clustered index customer_c1 on customer(c_w_id, c_d_id, c_id)
on MSSQL70_cs_fg

select @enddate = getdate()
select "End date: ", convert(varchar(30),@enddate,9)
select "Elapsed time (in seconds): ", datediff(second, @startdate, @enddate)

go
```

### idxcusnc.sql

## Appendix B - Database Design

---

```
-- File:      IDXCUSNC.SQL
--           Microsoft TPC-C Benchmark Kit Ver. 4.00
--           Copyright Microsoft, 1996
-- Purpose:   Creates non-clustered index on customer table

use tpcc
go

declare @startdate datetime
declare @enddate datetime
select @startdate = getdate()
select "Start date:", convert(varchar(30),@startdate,9)

if exists ( select name from sysindexes where name = 'customer_nc1' )
    drop index customer.customer_nc1

create unique nonclustered index customer_nc1 on customer(c_w_id, c_d_id, c_last,
c_first, c_id)
    on MSSQL70_cs_fg

select @enddate = getdate()
select "End date: ", convert(varchar(30),@enddate,9)
select "Elapsed time (in seconds): ", datediff(second, @startdate, @enddate)

go
```

### idxdiscl.sql

```
-- File:      IDXDISCL.SQL
--           Microsoft TPC-C Benchmark Kit Ver. 4.00
--           Copyright Microsoft, 1996
-- Purpose:   Creates clustered index on district table

use tpcc
go

declare @startdate datetime
declare @enddate datetime
select @startdate = getdate()
select "Start date:", convert(varchar(30),@startdate,9)

if exists ( select name from sysindexes where name = 'district_c1' )
    drop index district.district_c1

create unique clustered index district_c1 on district(d_w_id, d_id)
    with fillfactor=100 on MSSQL70_misc_fg

select @enddate = getdate()
select "End date: ", convert(varchar(30),@enddate,9)
select "Elapsed time (in seconds): ", datediff(second, @startdate, @enddate)

go
```

### idxitmcl.sql

```
-- File:      IDXITMCL.SQL
--           Microsoft TPC-C Benchmark Kit Ver. 4.00
--           Copyright Microsoft, 1996
-- Purpose:   Creates clustered index on item table

use tpcc
go

declare @startdate datetime
declare @enddate datetime
select @startdate = getdate()
select "Start date:", convert(varchar(30),@startdate,9)

if exists ( select name from sysindexes where name = 'item_c1' )
    drop index item.item_c1

create unique clustered index item_c1 on item(i_id)
    on MSSQL70_misc_fg

select @enddate = getdate()
select "End date: ", convert(varchar(30),@enddate,9)
select "Elapsed time (in seconds): ", datediff(second, @startdate, @enddate)

go
```

### idxnodcl.sql

```
-- File:      IDXNODCL.SQL
--           Microsoft TPC-C Benchmark Kit Ver. 4.00
--           Copyright Microsoft, 1996
-- Purpose:   Creates clustered index on new_order table

use tpcc
go

declare @startdate datetime
declare @enddate datetime
select @startdate = getdate()
select "Start date:", convert(varchar(30),@startdate,9)

if exists ( select name from sysindexes where name = 'new_order_c1' )
    drop index new_order.new_order_c1

create unique clustered index new_order_c1 on new_order(no_w_id, no_d_id, no_o_id)
    on MSSQL70_misc_fg

select @enddate = getdate()
select "End date: ", convert(varchar(30),@enddate,9)
select "Elapsed time (in seconds): ", datediff(second, @startdate, @enddate)

go
```

## Appendix B - Database Design

---

### idxodcl.sql

```
-- File:      IDXNODCL.SQL
--           Microsoft TPC-C Benchmark Kit Ver. 4.00
--           Copyright Microsoft, 1996
-- Purpose:   Creates clustered index on new_order table

use tpcc
go

declare @startdate datetime
declare @enddate datetime
select @startdate = getdate()
select "Start date:", convert(varchar(30),@startdate,9)

if exists ( select name from sysindexes where name = 'new_order_cl' )
    drop index new_order.new_order_cl

create unique clustered index new_order_cl on new_order(no_w_id, no_d_id, no_o_id)
    on MSSQL70_misc_fg

select @enddate = getdate()
select "End date: ", convert(varchar(30),@enddate,9)
select "Elapsed time (in seconds): ", datediff(second, @startdate, @enddate)

go
```

### idxordcl.sql

```
-- File:      IDXORDCL.SQL
--           Microsoft TPC-C Benchmark Kit Ver. 4.00
--           Copyright Microsoft, 1996
-- Purpose:   Creates clustered index on orders table

use tpcc
go

declare @startdate datetime
declare @enddate datetime
select @startdate = getdate()
select "Start date:", convert(varchar(30),@startdate,9)

if exists ( select name from sysindexes where name = 'orders_cl' )
    drop index orders.orders_cl

create unique clustered index orders_cl on orders(o_w_id, o_d_id, o_id)
    on MSSQL70_misc_fg

select @enddate = getdate()
select "End date: ", convert(varchar(30),@enddate,9)
select "Elapsed time (in seconds): ", datediff(second, @startdate, @enddate)

go
```

### idxstkcl.sql

```
-- File:      IDXSTKCL.SQL
--           Microsoft TPC-C Benchmark Kit Ver. 4.00
--           Copyright Microsoft, 1996
-- Purpose:   Creates clustered index on stock table

use tpcc
go

declare @startdate datetime
declare @enddate datetime
select @startdate = getdate()
select "Start date:", convert(varchar(30),@startdate,9)

if exists ( select name from sysindexes where name = 'stock_cl' )
    drop index stock.stock_cl

create unique clustered index stock_cl on stock(s_i_id, s_w_id)
    on MSSQL70_cs_fg

select @enddate = getdate()
select "End date: ", convert(varchar(30),@enddate,9)
select "Elapsed time (in seconds): ", datediff(second, @startdate, @enddate)

go
```

### idxwarcl.sql

```
-- File:      IDXWARCL.SQL
--           Microsoft TPC-C Benchmark Kit Ver. 4.00
--           Copyright Microsoft, 1996
-- Purpose:   Creates clustered index on warehouse table

use tpcc
go

declare @startdate datetime
declare @enddate datetime
select @startdate = getdate()
select "Start date:", convert(varchar(30),@startdate,9)

if exists ( select name from sysindexes where name = 'warehouse_cl' )
    drop index warehouse.warehouse_cl

create unique clustered index warehouse_cl on warehouse(w_id)
    with fillfactor=100 on MSSQL70_misc_fg

select @enddate = getdate()
select "End date: ", convert(varchar(30),@enddate,9)
```

## Appendix B - Database Design

---

```
select "Elapsed time (in seconds): ", datediff(second, @startdate, @enddate)
go
```

### dbopt1.sql

```
-- File:      DBOPT1.SQL
--           Microsoft TPC-C Benchmark Kit Ver. 4.00
--           Copyright Microsoft, 1996
-- Purpose:   Sets database options for data load
```

```
use master
go

exec sp_dboption tpcc,'select into/bulkcopy',true
exec sp_dboption tpcc,'trunc. log on chkpt.',true
go

use tpcc
go

checkpoint
go
```

### dbopt2.sql

```
-- File:      DBOPT2.SQL
--           Microsoft TPC-C Benchmark Kit Ver. 4.00
--           Copyright Microsoft, 1996
-- Purpose:   Resets database options after data load
```

```
use master
go

sp_dboption tpcc,'select ',false
go

sp_dboption tpcc,'trunc. ',false
go

use tpcc
go

checkpoint
go

sp_configure allow,1
go
```

```
reconfigure with override
go

/*
/* Set option values for user-defined indexes */
/*
*/

sp_indexoption 'customer','AllowPageLocks',FALSE
go
sp_indexoption 'district','AllowPageLocks',FALSE
go
sp_indexoption 'warehouse','AllowPageLocks',FALSE
go
sp_indexoption 'stock','AllowPageLocks',FALSE
go
sp_indexoption 'order_line','AllowPageLocks',FALSE
go
sp_indexoption 'orders','AllowPageLocks',FALSE
go
sp_indexoption 'new_order','AllowRowLocks',FALSE
go
sp_indexoption 'item','AllowRowLocks',FALSE
go
sp_indexoption 'item','AllowPageLocks',FALSE
go

Print ' '
Print '*****'
Print 'Pre-specified Locking Hierarchy:'
Print '  Lockflag = 0 ==> No pre-pecified hierarchy'
Print '  Lockflag = 1 ==> Lock at Page-level then Table-level'
Print '  Lockflag = 2 ==> Lock at Row-level then Table-level'
Print '  Lockflag = 3 ==> Lock at Table-level'
Print ' '

select name,lockflags
from sysindexes
where object_id("warehouse")=id or
      object_id("district")=id or
      object_id("customer")=id or
      object_id("stock")=id or
      object_id("orders")=id or
      object_id("order_line")=id or
      object_id("history")=id or
      object_id("new_order")=id or
      object_id("item")=id

order by lockflags asc
go

sp_configure allow,0
go

reconfigure with override
go

exec sp_dboption tpcc, 'auto update statistics', FALSE
exec sp_dboption tpcc, 'auto create statistics', FALSE
go

exec sp_tableoption "district","pintable",true
exec sp_tableoption "warehouse","pintable",true
exec sp_tableoption "new_order","pintable",true
exec sp_tableoption "item","pintable",true
```

## Appendix B - Database Design

---

```
go
```

### dbopt3.sql

```
use tpcc
go
sp_indexoption 'orders','AllowPagelocks',TRUE
go
sp_indexoption 'orders','AllowRowlocks',FALSE
go
sp_indexoption 'order_line','AllowPagelocks',TRUE
go
sp_indexoption 'order_line','AllowRowlocks',FALSE
go
```

### backup.sql

```
-- File:      BACKUP.SQL
--           Microsoft TPC-C Benchmark Kit Ver. 4.21
--           Copyright Microsoft, 1999, 2000
-- Purpose:   Creates backup of tpcc database

declare @startdate datetime
declare @enddate datetime
select @startdate = getdate()
select "Start date:", convert(varchar(30),@startdate,9)

dump database tpcc to tpcback1,tpccback2,tpccback3,tpccback4 with init, stats = 5

select @enddate = getdate()
select "End date: ", convert(varchar(30),@enddate,9)
select "Elapsed time (in seconds): ", datediff(second, @startdate, @enddate)

go
```

### restore.sql

```
-- File:      RESTORE.SQL
--           Microsoft TPC-C Benchmark Kit Ver. 4.21
--           Copyright Microsoft, 1999, 2000
-- Purpose:   Loads database backup from backup files

declare @startdate datetime
declare @enddate datetime
```

```
select @startdate = getdate()
select "Start date:", convert(varchar(30),@startdate,9)

load database tpcc from tpcback1,tpccback2,tpccback3,tpccback4 with stats = 5

select @enddate = getdate()
select "End date: ", convert(varchar(30),@enddate,9)
select "Elapsed time (in seconds): ", datediff(second, @startdate, @enddate)

go
```

# Appendix B - Database Design

## Stored Procedures

### neword.sql

```
-- File:      NEWORD.SQL
--           Microsoft TPC-C Benchmark Kit Ver. 4.01
--           Copyright Microsoft, 1996
-- Purpose:   Creates new order transaction stored procedure
--
-- Modified 9/21/98 - Jamie Reding - Microsoft Corporation
--           Reordered @rowcount check so that invalid supply warehouse id,
--           as well as invalid item id, is detected and causes explicit
--           transaction rollback.
--
use tpcc
go

if exists ( select name from sysobjects where name = "tpcc_neworder" )
    drop procedure tpcc_neworder
go

create proc tpcc_neworder

    @w_id      smallint,
    @d_id      tinyint,
    @c_id      int,
    @o_ol_cnt  tinyint,
    @o_all_local tinyint,
    @i_id1     int = 0, @s_w_id1 smallint = 0,
    @i_id2     int = 0, @s_w_id2 smallint = 0,
    @i_id3     int = 0, @s_w_id3 smallint = 0,
    @i_id4     int = 0, @s_w_id4 smallint = 0,
    @i_id5     int = 0, @s_w_id5 smallint = 0,
    @i_id6     int = 0, @s_w_id6 smallint = 0,
    @i_id7     int = 0, @s_w_id7 smallint = 0,
    @i_id8     int = 0, @s_w_id8 smallint = 0,
    @i_id9     int = 0, @s_w_id9 smallint = 0,
    @i_id10    int = 0, @s_w_id10 smallint =
    @i_id11    int = 0, @s_w_id11 smallint =
    @i_id12    int = 0, @s_w_id12 smallint =
    @i_id13    int = 0, @s_w_id13 smallint =

    @ol_qty1  smallint = 0,
    @ol_qty2  smallint = 0,
    @ol_qty3  smallint = 0,
    @ol_qty4  smallint = 0,
    @ol_qty5  smallint = 0,
    @ol_qty6  smallint = 0,
    @ol_qty7  smallint = 0,
    @ol_qty8  smallint = 0,
    @ol_qty9  smallint = 0,
    0, @ol_qty10 smallint = 0,
    0, @ol_qty11 smallint = 0,
    0, @ol_qty12 smallint = 0,
    0, @ol_qty13 smallint = 0,
```

```
    @i_id14   int = 0, @s_w_id14 smallint =
    0, @ol_qty14 smallint = 0,
    @i_id15   int = 0, @s_w_id15 smallint =
    0, @ol_qty15 smallint = 0

as
declare  @w_tax      numeric(4,4),
    @d_tax      numeric(4,4),
    @c_last     char(16),
    @c_credit   char(2),
    @c_discount numeric(4,4),
    @i_price    numeric(5,2),
    @i_name     char(24),
    @i_data     char(50),
    @o_entry_d  datetime,
    @remote_flag int,
    @s_quantity smallint,
    @s_data     char(50),
    @s_dist     char(24),
    @li_no      int,
    @o_id       int,
    @commit_flag tinyint,
    @li_id      int,
    @li_s_w_id  smallint,
    @li_qty     smallint,
    @ol_number  int,
    @c_id_local int

begin

    begin transaction n

-- get district tax and next available order id and update
-- plus initialize local variables

    update district
    set      @d_tax      = d_tax,
            @o_id       = d_next_o_id,
            d_next_o_id = d_next_o_id + 1,
            @o_entry_d  = getdate(),
            @li_no      = 0,
            @commit_flag = 1

    where   d_w_id     = @w_id and
            d_id       = @d_id

-- process orderlines

    while (@li_no < @o_ol_cnt)
        begin

            select @li_no = @li_no + 1

-- set i_id, s_w_id, and qty for this lineitem

            select @li_id = case @li_no
                when 1 then @i_id1
                when 2 then @i_id2
                when 3 then @i_id3
                when 4 then @i_id4
                when 5 then @i_id5
                when 6 then @i_id6
                when 7 then @i_id7
```

## Appendix B - Database Design

```
when 8 then @i_id8
when 9 then @i_id9
when 10 then @i_id10
when 11 then @i_id11
when 12 then @i_id12
when 13 then @i_id13
when 14 then @i_id14
when 15 then @i_id15
end,

@li_s_w_id = case @li_no
when 1 then @s_w_id1
when 2 then @s_w_id2
when 3 then @s_w_id3
when 4 then @s_w_id4
when 5 then @s_w_id5
when 6 then @s_w_id6
when 7 then @s_w_id7
when 8 then @s_w_id8
when 9 then @s_w_id9
when 10 then @s_w_id10
when 11 then @s_w_id11
when 12 then @s_w_id12
when 13 then @s_w_id13
when 14 then @s_w_id14
when 15 then @s_w_id15
end,

@li_qty = case @li_no
when 1 then @ol_qty1
when 2 then @ol_qty2
when 3 then @ol_qty3
when 4 then @ol_qty4
when 5 then @ol_qty5
when 6 then @ol_qty6
when 7 then @ol_qty7
when 8 then @ol_qty8
when 9 then @ol_qty9
when 10 then @ol_qty10
when 11 then @ol_qty11
when 12 then @ol_qty12
when 13 then @ol_qty13
when 14 then @ol_qty14
when 15 then @ol_qty15
end

-- get item data (no one updates item)
select  @i_price = i_price,
        @i_name = i_name,
        @i_data = i_data
from    item (tablock repeatableread)
where   i_id = @li_id

-- update stock values
update  stock
set     s_ytd      = s_ytd + @li_qty,
        @s_quantity = s_quantity -
@li_qty +
        case when (s_quantity - @li_qty < 10) then 91 else 0 end,
        s_order_cnt = s_order_cnt + 1,

s_remote_cnt = s_remote_cnt +
case when (@li_s_w_id = @w_id) then 0 else 1 end,
@s_data      = s_data,
@s_dist      = case @d_id
when 1
when 2 then s_dist_02
when 3 then s_dist_03
when 4 then s_dist_04
when 5 then s_dist_05
when 6 then s_dist_06
when 7 then s_dist_07
when 8 then s_dist_08
when 9 then s_dist_09
when 10 then s_dist_10
end
where    s_i_id      = @li_id and
         s_w_id      = @li_s_w_id

-- if there actually is a stock (and item) with these ids, go to work
if (@@rowcount > 0)
begin
-- insert order_line data (using data from item and stock)
insert into order_line values(@o_id,
@i_id,
@w_id,
@li_no,
@li_id,
@li_s_w_id,
"dec 31, 1899",
@li_qty,
@i_price * @li_qty,
@s_dist)

-- send line-item data to client
select  @i_name,
@s_quantity,
b_g = case when (
(patindex("%ORIGINAL%",@i_data) > 0) and
(patindex("%ORIGINAL%",@s_data) > 0) )
then "B" else "G"
end,
@s_price,
@s_price * @li_qty
else
end
```

## Appendix B - Database Design

```
begin
-- no item (or stock) found - triggers rollback condition
        select "",0,"",0,0
        select @commit_flag = 0
end
end
-- get customer last name, discount, and credit rating
select      @c_last      = c_last,
            @c_discount = c_discount,
            @c_credit    = c_credit,
            @c_id_local  = c_id
from customer (repeatableread)
where c_id      = @c_id and
       c_w_id   = @w_id and
       c_d_id   = @d_id
-- insert fresh row into orders table
insert into orders values (@o_id,
                           @d_id,
                           @w_id,
                           @c_id_local,
                           @o_entry_d,
                           0,
                           @o_ol_cnt,
                           @o_all_local)
-- insert corresponding row into new-order table
insert into new_order values (@o_id,
                              @d_id,
                              @w_id)
-- select warehouse tax
select  @w_tax = w_tax
from    warehouse (repeatableread)
where   w_id   = @w_id
if (@commit_flag = 1)
    commit transaction n
else
-- all that work for nuthin!!!
    rollback transaction n
-- return order data to client
select @w_tax,
       @d_tax,
       @o_id,
       @c_last,
       @c_discount,
       @c_credit,
       @o_entry_d,
       @commit_flag
```

```
end
go

payment.sql

-- File:      PAYMENT.SQL
--           Microsoft TPC-C Benchmark Kit Ver. 4.00
--           Copyright Microsoft, 1996
-- Purpose:   Creates payment transaction stored procedure

use tpcc
go
if exists (select name from sysobjects where name = "tpcc_payment" )
    drop procedure tpcc_payment
go
create proc tpcc_payment @w_id          smallint,
                        @c_w_id        smallint,
                        @h_amount      numeric(6,2),
                        @d_id          tinyint,
                        @c_d_id        tinyint,
                        @c_id          int,
                        @c_last        char(16) =
""
as
declare @w_street_1 char(20),
        @w_street_2 char(20),
        @w_city     char(20),
        @w_state    char(2),
        @w_zip      char(9),
        @w_name     char(10),
        @d_street_1 char(20),
        @d_street_2 char(20),
        @d_city     char(20),
        @d_state    char(2),
        @d_zip      char(9),
        @d_name     char(10),
        @c_first    char(16),
        @c_middle   char(2),
        @c_street_1 char(20),
        @c_street_2 char(20),
        @c_city     char(20),
        @c_state    char(2),
        @c_zip      char(9),
        @c_phone    char(16),
        @c_since    datetime,
        @c_credit   char(2),
        @c_credit_lim numeric(12,2),
        @c_balance  numeric(12,2),
        @c_discount numeric(4,4),
        @data       char(500),
        @c_data     char(500),
        @datetime   datetime,
        @w_ytd      numeric(12,2),
```

## Appendix B - Database Design

```
@d_ytd          numeric(12,2),
@cnt            smallint,
@val           smallint,
@screen_data   char(200),
               @d_id_local   tinyint,
               @w_id_local   smallint,
               @c_id_local   int

select @screen_data = ""

begin tran p

-- get payment date

select @datetime = getdate()

if (@c_id = 0)
begin

-- get customer id and info using last name

select @cnt = count(*)
from customer (repeatableread)
where c_last = @c_last and
      c_w_id = @c_w_id and
      c_d_id = @c_d_id

select @val = (@cnt + 1) / 2
set rowcount @val

select @c_id = c_id
from customer (repeatableread)
where c_last = @c_last and
      c_w_id = @c_w_id and
      c_d_id = @c_d_id
order by c_last, c_first

set rowcount 0

end

-- get customer info and update balances

update customer set
  @c_balance      = c_balance = c_balance - @h_amount,
  c_payment_cnt   = c_payment_cnt + 1,
  c_ytd_payment   = c_ytd_payment + @h_amount,
  @c_first        = c_first,
  @c_middle       = c_middle,
  @c_last         = c_last,
  @c_street_1     = c_street_1,
  @c_street_2     = c_street_2,
  @c_city         = c_city,
  @c_state        = c_state,
  @c_zip          = c_zip,
  @c_phone        = c_phone,
  @c_credit       = c_credit,
  @c_credit_lim   = c_credit_lim,
  @c_discount     = c_discount,
  @c_since        = c_since,
  @data          = c_data,
  @c_id_local     = c_id
where c_id = @c_id and

      c_w_id = @c_w_id and
      c_d_id = @c_d_id

-- if customer has bad credit get some more info

if (@c_credit = "BC")
begin

-- compute new info

select @c_data = convert(char(5),@c_id) +
              convert(char(4),@c_d_id) +
              convert(char(5),@c_w_id) +
              convert(char(4),@d_id) +
              convert(char(5),@w_id) +
              convert(char(19),@h_amount) +
              substring(@data, 1, 458)

-- update customer info

update customer set
  c_data = @c_data
where c_id = @c_id and
      c_w_id = @c_w_id and
      c_d_id = @c_d_id

select @screen_data = substring (@c_data,1,200)

end

-- get district data and update year-to-date

update district
set d_ytd = d_ytd + @h_amount,
    @d_street_1 = d_street_1,
    @d_street_2 = d_street_2,
    @d_city = d_city,
    @d_state = d_state,
    @d_zip = d_zip,
    @d_name = d_name,
    @d_id_local = d_id
where d_w_id = @w_id and
      d_id = @d_id

-- get warehouse data and update year-to-date

update warehouse
set w_ytd = w_ytd + @h_amount,
    @w_street_1 = w_street_1,
    @w_street_2 = w_street_2,
    @w_city = w_city,
    @w_state = w_state,
    @w_zip = w_zip,
    @w_name = w_name,
    @w_id_local = w_id
where w_id = @w_id

-- create history record

insert into history values (@c_id_local,
                           @c_d_id,
                           @c_w_id,
                           @d_id_local,
```

## Appendix B - Database Design

```
@w_id_local,
@datetime,
@h_amount,
+ " " + @d_name)
@w_name
commit tran p
-- return data to client
select @c_id,
@c_last,
@datetime,
@w_street_1,
@w_street_2,
@w_city,
@w_state,
@w_zip,
@d_street_1,
@d_street_2,
@d_city,
@d_state,
@d_zip,
@c_first,
@c_middle,
@c_street_1,
@c_street_2,
@c_city,
@c_state,
@c_zip,
@c_phone,
@c_since,
@c_credit,
@c_credit_lim,
@c_discount,
@c_balance,
@screen_data
go
```

### ordstat.sql

```
-- File: ORDSTAT.SQL
-- Microsoft TPC-C Benchmark Kit Ver. 4.00
-- Copyright Microsoft, 1996
-- Purpose: Creates order status transaction stored procedure
use tpcc
go
if exists ( select name from sysobjects where name = "tpcc_orderstatus" )
drop procedure tpcc_orderstatus
go
create proc tpcc_orderstatus @w_id smallint,
```

```
tinyint,
int,
= ""
as
declare @c_balance numeric(12,2),
@c_first char(16),
@c_middle char(2),
@o_id int,
@o_entry_d datetime,
@o_carrier_id smallint,
@cnt smallint
begin tran o
if (@c_id = 0)
begin
-- get customer id and info using last name
select @cnt = (count(*)+1)/2
from customer (repeatableread)
where c_last = @c_last and
c_w_id = @w_id and
c_d_id = @d_id
set rowcount @cnt
select @c_id = c_id,
@c_balance = c_balance,
@c_first = c_first,
@c_last = c_last,
@c_middle = c_middle
from customer (repeatableread)
where c_last = @c_last and
c_w_id = @w_id and
c_d_id = @d_id
order by c_w_id, c_d_id, c_last, c_first
set rowcount 0
end
else
begin
-- get customer info if by id
select @c_balance = c_balance,
@c_first = c_first,
@c_middle = c_middle,
@c_last = c_last
from customer (repeatableread)
where c_id = @c_id and
c_d_id = @d_id and
c_w_id = @w_id
select @cnt = @@rowcount
end
```

## Appendix B - Database Design

```
-- if no such customer
    if (@cnt = 0)
    begin
        raiserror("Customer not found",18,1)
        goto custnotfound
    end
-- get order info
    select @o_id = o_id,
           @o_entry_d = o_entry_d,
           @o_carrier_id = o_carrier_id
    from orders (serializable)
    where o_c_id = @c_id and
          o_d_id = @d_id and
          o_w_id = @w_id
    order by o_id asc
-- select order lines for the current order
    select ol_supply_w_id,
           ol_i_id,
           ol_quantity,
           ol_amount,
           ol_delivery_d
    from order_line (repeatable)
    where ol_o_id = @o_id and
          ol_d_id = @d_id and
          ol_w_id = @w_id

custnotfound:
commit tran o
-- return data to client
select @c_id,
       @c_last,
       @c_first,
       @c_middle,
       @o_entry_d,
       @o_carrier_id,
       @c_balance,
       @o_id

go
```

### delivery.sql

```
-- File:      DELIVERY.SQL
--           Microsoft TPC-C Benchmark Kit Ver. 4.00
--           Copyright Microsoft, 1996
-- Purpose:   Creates delivery transaction stored procedure
```

```
use tpcc
go
if exists (select name from sysobjects where name = "tpcc_delivery" )
    drop procedure tpcc_delivery
go
create proc tpcc_delivery    @w_id            smallint,
                             @o_carrier_id  smallint
as
declare @d_id tinyint,
        @o_id int,
        @c_id int,
        @total numeric(12,2),
        @oid1 int,
        @oid2 int,
        @oid3 int,
        @oid4 int,
        @oid5 int,
        @oid6 int,
        @oid7 int,
        @oid8 int,
        @oid9 int,
        @oid10 int

select @d_id = 0

begin tran d

    while (@d_id < 10)
    begin

        select @d_id = @d_id + 1,
               @total = 0,
               @o_id = 0

                select top 1 @o_id = no_o_id
                from new_order (serializable uplock)
                where no_w_id = @w_id and
                      no_d_id = @d_id
                order by no_o_id asc

        if (@@rowcount <> 0)
        begin

-- claim the order for this district

            delete new_order
            where no_w_id = @w_id and
                  no_d_id = @d_id and
                  no_o_id = @o_id

-- set carrier_id on this order (and get customer id)

            update orders
            set o_carrier_id = @o_carrier_id,
                @c_id = o_c_id
            where o_w_id = @w_id and
                  o_d_id = @d_id and
                  o_id = @o_id
```

## Appendix B - Database Design

```
-- set date in all lineitems for this order (and sum amounts)

update order_line
    set ol_delivery_d = getdate(),
        @total        = @total + ol_amount
where ol_w_id = @w_id and
    ol_d_id = @d_id and
        ol_o_id = @o_id

-- accumulate lineitem amounts for this order into customer

update customer
    set c_balance      = c_balance + @total,
        c_delivery_cnt = c_delivery_cnt + 1
where c_w_id = @w_id and
    c_d_id = @d_id and
        c_id = @c_id

end

select @oid1 = case @d_id when 1 then @o_id else @oid1 end,
    @oid2 = case @d_id when 2 then @o_id else @oid2 end,
    @oid3 = case @d_id when 3 then @o_id else @oid3 end,
    @oid4 = case @d_id when 4 then @o_id else @oid4 end,
    @oid5 = case @d_id when 5 then @o_id else @oid5 end,
    @oid6 = case @d_id when 6 then @o_id else @oid6 end,
    @oid7 = case @d_id when 7 then @o_id else @oid7 end,
    @oid8 = case @d_id when 8 then @o_id else @oid8 end,
    @oid9 = case @d_id when 9 then @o_id else @oid9 end,
    @oid10 = case @d_id when 10 then @o_id else @oid10 end

end

commit tran d

-- return delivery data to client

select @oid1,
    @oid2,
    @oid3,
    @oid4,
    @oid5,
    @oid6,
    @oid7,
    @oid8,
    @oid9,
    @oid10

go
```

### stocklev.sql

```
-- File:      STOCKLEV.SQL
--            Microsoft TPC-C Benchmark Kit Ver. 4.00
--            Copyright Microsoft, 1996
-- Purpose:   Creates stock level transaction stored procedure

use tpcc
go
```

```
if exists (select name from sysobjects where name = "tpcc_stocklevel" )
    drop procedure tpcc_stocklevel
go

create proc tpcc_stocklevel @w_id          smallint,
                           @d_id          tinyint,
                           @threshold    smallint

as

    declare @o_id_low int,
            @o_id_high int

    select @o_id_low = (d_next_o_id - 20),
           @o_id_high = (d_next_o_id - 1)
    from district
    where d_w_id = @w_id and
          d_id = @d_id

    select count(distinct(s_i_id))
    from stock, order_line
    where ol_w_id = @w_id and
          ol_d_id = @d_id and
          ol_o_id between @o_id_low and @o_id_high and
          s_w_id = ol_w_id and
          s_i_id = ol_i_id and
          s_quantity < @threshold

go
```

### Loader Source Code

#### tpcc.h

```
// File:      TPCC.H
//            Microsoft TPC-C Kit Ver. 4.00
//            Copyright Microsoft, 1996, 1997, 1998

// Purpose:   Header file for TPC-C database loader

// Build number of TPC Benchmark Kit
#define TPCKIT_VER "4.00"

// General headers
#include <windows.h>
#include <winbase.h>
#include <stdlib.h>
#include <stdio.h>
#include <process.h>
#include <stddef.h>
#include <stdarg.h>
#include <string.h>
```

## Appendix B - Database Design

```

#include <time.h>
#include <sys\timeb.h>
#include <sys\types.h>

// ODBC headers
#include <sql.h>
#include <sqllex.h>
#include <odbcss.h>

// General constants
#define MILLI 1000
#define FALSE 0
#define TRUE 1
#define UNDEF -1
#define MINPRINTASCII 32
#define MAXPRINTASCII 126

// Default environment constants
#define SERVER ""
#define DATABASE "tpcc"
#define USER "sa"
#define PASSWORD ""

// Default loader arguments
#define BATCH 10000
#define DEFLOADPACKSIZE 32768
#define ORDERS_PER_DIST 3000
#define LOADER_RES_FILE "logs\\load.out"
#define LOADER_NURAND_C 123
#define DEF_STARTING_WAREHOUSE 1
#define BUILD_INDEX 1 // build both data
and indexes
#define INDEX_ORDER 1 // build indexes
before load
#define SCALE_DOWN 0 // build a normal scale
database
#define INDEX_SCRIPT_PATH "scripts"

typedef struct
{
    char *server;
    char *database;
    char *user;
    char *password;
    BOOL tables_all;
    // set if loading all tables
    BOOL table_item;
    // set if loading ITEM table specifically
    BOOL table_warehouse; // set if loading
WAREHOUSE, DISTRICT, and STOCK
    BOOL table_customer; // set if
loading CUSTOMER and HISTORY
    BOOL table_orders; // set if
loading NEW-ORDER, ORDERS, ORDER-LINE
    long num_warehouses;
    long batch;
    long verbose;
    long pack_size;
    char *loader_res_file;
    char *synch_servername;
    long case_sensitivity;
    long starting_warehouse;
    long build_index;

```

```

    long index_order;
    long scale_down;
    char *index_script_path;
} TPCCCLR_ARGS;

// String length constants
#define SERVER_NAME_LEN 20
#define DATABASE_NAME_LEN 20
#define USER_NAME_LEN 20
#define PASSWORD_LEN 20
#define TABLE_NAME_LEN 20
#define I_DATA_LEN 50
#define I_NAME_LEN 24
#define BRAND_LEN 1
#define LAST_NAME_LEN 16
#define W_NAME_LEN 10
#define ADDRESS_LEN 20
#define STATE_LEN 2
#define ZIP_LEN 9
#define S_DIST_LEN 24
#define S_DATA_LEN 50
#define D_NAME_LEN 10
#define FIRST_NAME_LEN 16
#define MIDDLE_NAME_LEN 2
#define PHONE_LEN 16
#define CREDIT_LEN 2
#define C_DATA_LEN 500
#define H_DATA_LEN 24
#define DIST_INFO_LEN 24
#define MAX_OL_NEW_ORDER_ITEMS 15
#define MAX_OL_ORDER_STATUS_ITEMS 15
#define STATUS_LEN 25
#define OL_DIST_INFO_LEN 24
#define C_SINCE_LEN 23
#define H_DATE_LEN 23
#define OL_DELIVERY_D_LEN 23
#define O_ENTRY_D_LEN 23

// Functions in random.c
void seed();
long irand();
double drand();
void WUcreate();
short WURand();
long RandomNumber(long lower, long upper);

// Functions in getargs.c
void GetArgsLoader();
void GetArgsLoaderUsage();

// Functions in time.c
long TimeNow();

// Functions in strings.c
void MakeAddress();
void LastName();
int MakeAlphaString();
int MakeOriginalAlphaString();
int MakeNumberString();
int MakeZipNumberString();
void InitString();
void InitAddress();

```

# Appendix B - Database Design

```
void PaddString();
```

## tpccldr.c

```
// File: TPCCLDR.C
// Microsoft TPC-C Kit Ver. 4.00
// Copyright Microsoft, 1996, 1997, 1998
// Purpose: Source file for TPC-C database loader

// Includes
#include "tpcc.h"
#include "search.h"

// Defines
#define MAXITEMS 100000
#define MAXITEMS_SCALE_DOWN 100
#define CUSTOMERS_PER_DISTRICT 3000
#define CUSTOMERS_SCALE_DOWN 30
#define DISTRICT_PER_WAREHOUSE 10
#define ORDERS_PER_DISTRICT 3000
#define ORDERS_SCALE_DOWN 30
#define MAX_CUSTOMER_THREADS 2
#define MAX_ORDER_THREADS 3
#define MAX_MAIN_THREADS 4

// Functions declarations

void HandleErrorDBC (SQLHDBC hdbc1);

long NURand();
void LoadItem();
void LoadWarehouse();

void Stock();
void District();

void LoadCustomer();
void CustomerBufInit();
void CustomerBufLoad();
void LoadCustomerTable();
void LoadHistoryTable();

void LoadOrders();
void OrdersBufInit();
void OrdersBufLoad();
void LoadOrdersTable();
void LoadNewOrderTable();
void LoadOrderLineTable();
void GetPermutation();
void CheckForCommit();
void OpenConnections();
void BuildIndex();
void FormatDate ();
```

```
// Shared memory structures
```

```
typedef struct
{
    long ol;
    long ol_i_id;
    short ol_supply_w_id;
    short ol_quantity;
    double ol_amount;
    char ol_dist_info[DIST_INFO_LEN+1];
    char ol_delivery_d[OL_DELIVERY_D_LEN+1];
} ORDER_LINE_STRUCT;

typedef struct
{
    long o_id;
    short o_d_id;
    short o_w_id;
    long o_c_id;
    short o_carrier_id;
    short o_ol_cnt;
    short o_all_local;
    ORDER_LINE_STRUCT o_ol[15];
} ORDERS_STRUCT;

typedef struct
{
    long c_id;
    short c_d_id;
    short c_w_id;
    char c_first[FIRST_NAME_LEN+1];
    char c_middle[MIDDLE_NAME_LEN+1];
    char c_last[LAST_NAME_LEN+1];
    char c_street_1[ADDRESS_LEN+1];
    char c_street_2[ADDRESS_LEN+1];
    char c_city[ADDRESS_LEN+1];
    char c_state[STATE_LEN+1];
    char c_zip[ZIP_LEN+1];
    char c_phone[PHONE_LEN+1];
    char c_credit[CREDIT_LEN+1];
    double c_credit_lim;
    double c_discount;
    // fix to avoid ODBC float to numeric conversion problem.
    // double c_balance;
    char c_balance[6];

    double c_ytd_payment;
    short c_payment_cnt;
    short c_delivery_cnt;
    char c_data[C_DATA_LEN+1];
    double h_amount;
    char h_data[H_DATA_LEN+1];
} CUSTOMER_STRUCT;

typedef struct
{
    char c_last[LAST_NAME_LEN+1];
    char c_first[FIRST_NAME_LEN+1];
    long c_id;
} CUSTOMER_SORT_STRUCT;

typedef struct
{
```

## Appendix B - Database Design

```
    long          time_start;
} LOADER_TIME_STRUCT;

// Global variables

char          szLastError[300];

HENV          henv;

HDBC          i_hdbc1;          // for ITEM table
HDBC          w_hdbc1;          // for WAREHOUSE, DISTRICT,
STOCK
HDBC          c_hdbc1;          // for CUSTOMER
HDBC          c_hdbc2;          // for HISTORY
HDBC          o_hdbc1;          // for ORDERS
HDBC          o_hdbc2;          // for NEW-ORDER

HDBC          o_hdbc3;          // for ORDER-LINE

HSTMT         i_hstmt1;
HSTMT         w_hstmt1;
HSTMT         c_hstmt1, c_hstmt2;
HSTMT         o_hstmt1, o_hstmt2, o_hstmt3;

ORDERS_STRUCT orders_buf[ORDERS_PER_DISTRICT];
CUSTOMER_STRUCT customer_buf[CUSTOMERS_PER_DISTRICT];
long          orders_rows_loaded;
long          new_order_rows_loaded;
long          order_line_rows_loaded;
long          history_rows_loaded;
long          customer_rows_loaded;
long          stock_rows_loaded;
long          district_rows_loaded;
long          item_rows_loaded;
long          warehouse_rows_loaded;
long          main_time_start;
long          main_time_end;
long          max_items;
long          customers_per_district;
long          orders_per_district;
long          first_new_order;
long          last_new_order;

TPCC_LDR_ARGS *aptr, args;

//=====
//
// Function name: main
//
//=====

int main(int argc, char **argv)
{
    DWORD          dwThreadId[MAX_MAIN_THREADS];
    HANDLE          hThread[MAX_MAIN_THREADS];
    FILE           *fLoader;
    char           buffer[255];
    int            i;
```

```
    for (i=0; i<MAX_MAIN_THREADS; i++)
        hThread[i] = NULL;

    printf("\n*****");
    printf("\n*                               **");
    printf("\n*   Microsoft SQL Server         **");
    printf("\n*                               **");
    printf("\n*   TPC-C BENCHMARK KIT:  Database loader   **");
    printf("\n*   Version %s                  *", TPCKIT_VER);
    printf("\n*                               **");
    printf("\n*****\n\n");

    // process command line arguments

    aptr = &args;
    GetArgsLoader(argc, argv, aptr);

    printf("Build interface is ODBC.\n");

    if (aptr->build_index == 0)
        printf("Data load only - no index creation.\n");
    else
        printf("Data load and index creation.\n");

    if (aptr->index_order == 0)
        printf("Clustered indexes will be created after bulk load.\n");
    else
        printf("Clustered indexes will be created before bulk load.\n");

    // set database scale values
    if (aptr->scale_down == 1)
    {
        printf("*** Scaled Down Database ***\n");
        max_items = MAXITEMS_SCALE_DOWN;
        customers_per_district = CUSTOMERS_SCALE_DOWN;
        orders_per_district = ORDERS_SCALE_DOWN;
        first_new_order = 0;
        last_new_order = 30;
    }
    else
    {
        max_items = MAXITEMS;
        customers_per_district = CUSTOMERS_PER_DISTRICT;
        orders_per_district = ORDERS_PER_DISTRICT;
        first_new_order = 2100;
        last_new_order = 3000;
    }

    // open connections to SQL Server
    OpenConnections();

    // open file for loader results
    fLoader = fopen(aptr->loader_res_file, "w");

    if (fLoader == NULL)
    {
        printf("Error, loader result file open failed.");
        exit(-1);
    }

    // start loading data
```

## Appendix B - Database Design

```
    sprintf(buffer,"TPC-C load started for %ld warehouses.\n",aptr->num_warehouses);
    printf("%s",buffer);
    fprintf(fLoader,"%s",buffer);
    main_time_start = (TimeNow() / MILLI);
    // start parallel load threads

    if (aptr->tables_all || aptr->table_item)
    {
        fprintf(fLoader, "\nStarting loader threads for: item\n");
        hThread[0] = CreateThread(NULL,
                                0,
                                (LPTHREAD_START_ROUTINE) LoadItem,
                                NULL,
                                0,
                                &dwThreadID[0]);
        if (hThread[0] == NULL)
        {
            printf("Error, failed in creating creating thread = 0.\n");
            exit(-1);
        }
    }
    if (aptr->tables_all || aptr->table_warehouse)
    {
        fprintf(fLoader, "Starting loader threads for: warehouse\n");
        hThread[1] = CreateThread(NULL,
                                0,
                                (LPTHREAD_START_ROUTINE) LoadWarehouse,
                                NULL,
                                0,
                                &dwThreadID[1]);
        if (hThread[1] == NULL)
        {
            printf("Error, failed in creating creating thread = 1.\n");
            exit(-1);
        }
    }
    if (aptr->tables_all || aptr->table_customer)
    {
        fprintf(fLoader, "Starting loader threads for: customer\n");
        hThread[2] = CreateThread(NULL,
                                0,
                                (LPTHREAD_START_ROUTINE) LoadCustomer,
                                NULL,
                                0,
                                &dwThreadID[2]);
    }
```

```
    if (hThread[2] == NULL)
    {
        printf("Error, failed in creating creating main thread =
2.\n");
        exit(-1);
    }
    if (aptr->tables_all || aptr->table_orders)
    {
        fprintf(fLoader, "Starting loader threads for: orders\n");
        hThread[3] = CreateThread(NULL,
                                0,
                                (LPTHREAD_START_ROUTINE) LoadOrders,
                                NULL,
                                0,
                                &dwThreadID[3]);
        if (hThread[3] == NULL)
        {
            printf("Error, failed in creating creating main thread =
3.\n");
            exit(-1);
        }
    }
    // Wait for threads to finish...
    for (i=0; i<MAX_MAIN_THREADS; i++)
    {
        if (hThread[i] != NULL)
        {
            WaitForSingleObject( hThread[i], INFINITE );
            CloseHandle(hThread[i]);
            hThread[i] = NULL;
        }
    }
    main_time_end = (TimeNow() / MILLI);
    sprintf(buffer,"\nTPC-C load completed successfully in %ld minutes.\n",
            (main_time_end - main_time_start)/60);
    printf("%s",buffer);
    fprintf(fLoader, "%s", buffer);
    fclose(fLoader);
    SQLFreeEnv(henv);
    exit(0);
    return 0;
}
//=====
//
// Function name: LoadItem
//
//=====
```

## Appendix B - Database Design

```
void LoadItem()
{
    long          i_id;
    long          i_im_id;
    char          i_name[I_NAME_LEN+1];
    double        i_price;
    char          i_data[I_DATA_LEN+1];
    char          name[20];
    long          time_start;
    RETCODE       rc;
    DBINT         rcint;
    char          bcphint[128];

    // Seed with unique number
    seed(1);

    printf("Loading item table...\n");

    // if build index before load
    if ((aptr->build_index == 1) && (aptr->index_order == 1))
        BuildIndex("idxitm1");

    InitString(i_name, I_NAME_LEN+1);
    InitString(i_data, I_DATA_LEN+1);

    sprintf(name, "%s..%s", aptr->database, "item");

    rc = bcp_init(i_hdbc1, name, NULL, "logs\\item.err", DB_IN);
    if (rc != SUCCEED)
        HandleErrorDBC(i_hdbc1);

    if ((aptr->build_index == 1) && (aptr->index_order == 1))
    {
        sprintf(bcphint, "tablock, order (i_id), ROWS_PER_BATCH = 100000");
        rc = bcp_control(i_hdbc1, BCPHINTS, (void*) bcphint);
        if (rc != SUCCEED)
            HandleErrorDBC(i_hdbc1);
    }

1);
    rc = bcp_bind(i_hdbc1, (BYTE *) &i_id, 0, SQL_VARLEN_DATA, NULL, 0, SQLINT4,
    if (rc != SUCCEED)
        HandleErrorDBC(i_hdbc1);

2);
    rc = bcp_bind(i_hdbc1, (BYTE *) &i_im_id, 0, SQL_VARLEN_DATA, NULL, 0, SQLINT4,
    if (rc != SUCCEED)
        HandleErrorDBC(i_hdbc1);

    rc = bcp_bind(i_hdbc1, (BYTE *) i_name, 0, I_NAME_LEN, NULL, 0, 0, 3);
    if (rc != SUCCEED)
        HandleErrorDBC(i_hdbc1);

4);
    rc = bcp_bind(i_hdbc1, (BYTE *) &i_price, 0, SQL_VARLEN_DATA, NULL, 0, SQLFLT8,
    if (rc != SUCCEED)
        HandleErrorDBC(i_hdbc1);

    rc = bcp_bind(i_hdbc1, (BYTE *) i_data, 0, I_DATA_LEN, NULL, 0, 0, 5);
    if (rc != SUCCEED)
        HandleErrorDBC(i_hdbc1);
```

```
time_start = (TimeNow() / MILLI);

item_rows_loaded = 0;

for (i_id = 1; i_id <= max_items; i_id++)
{
    i_im_id = RandomNumber(1L, 10000L);

    MakeAlphaString(14, 24, I_NAME_LEN, i_name);

    i_price = ((float) RandomNumber(100L, 10000L))/100.0;

    MakeOriginalAlphaString(26, 50, I_DATA_LEN, i_data, 10);

    rc = bcp_sendrow(i_hdbc1);
    if (rc != SUCCEED)
        HandleErrorDBC(i_hdbc1);

    item_rows_loaded++;
    CheckForCommit(i_hdbc1, i_hstmt1, item_rows_loaded, "item",
&time_start);
}

rcint = bcp_done(i_hdbc1);
if (rcint < 0)
    HandleErrorDBC(i_hdbc1);

printf("Finished loading item table.\n");

SQLFreeStmt(i_hstmt1, SQL_DROP);
SQLDisconnect(i_hdbc1);
SQLFreeConnect(i_hdbc1);

// if build index after load
if ((aptr->build_index == 1) && (aptr->index_order == 0))
    BuildIndex("idxitm1");
}

//=====
//
// Function : LoadWarehouse
//
// Loads WAREHOUSE table and loads Stock and District as Warehouses are created
//
//=====

void LoadWarehouse()
{
    short w_id;
    char w_name[W_NAME_LEN+1];
    char w_street_1[ADDRESS_LEN+1];
    char w_street_2[ADDRESS_LEN+1];
    char w_city[ADDRESS_LEN+1];
    char w_state[STATE_LEN+1];
    char w_zip[ZIP_LEN+1];
    double w_tax;
    double w_ytd;
    char name[20];
    long time_start;
    RETCODE rc;
    DBINT rcint;
```

## Appendix B - Database Design

```
char    bcphint[128];

// Seed with unique number
seed(2);

printf("Loading warehouse table...\n");

// if build index before load...
if ((aptr->build_index == 1) && (aptr->index_order == 1))
    BuildIndex("idxwarcl");

InitString(w_name, W_NAME_LEN+1);
InitAddress(w_street_1, w_street_2, w_city, w_state, w_zip);

sprintf(name, "%s.%s", aptr->database, "warehouse");

rc = bcp_init(w_hdbc1, name, NULL, "logs\\whouse.err", DB_IN);
if (rc != SUCCEED)
    HandleErrorDBC(w_hdbc1);

if ((aptr->build_index == 1) && (aptr->index_order == 1))
{
    sprintf(bcphint, "tablock, order (w_id), ROWS_PER_BATCH = %d", aptr-
>num_warehouses);
    rc = bcp_control(w_hdbc1, BCPHINTS, (void*) bcphint);
    if (rc != SUCCEED)
        HandleErrorDBC(w_hdbc1);
}

rc = bcp_bind(w_hdbc1, (BYTE *) &w_id, 0, SQL_VARLEN_DATA, NULL, 0, SQLINT2,
1);
if (rc != SUCCEED)
    HandleErrorDBC(w_hdbc1);

rc = bcp_bind(w_hdbc1, (BYTE *) w_name, 0, W_NAME_LEN, NULL, 0, 0, 2);
if (rc != SUCCEED)
    HandleErrorDBC(w_hdbc1);

rc = bcp_bind(w_hdbc1, (BYTE *) w_street_1, 0, ADDRESS_LEN, NULL, 0, 0, 3);
if (rc != SUCCEED)
    HandleErrorDBC(w_hdbc1);

rc = bcp_bind(w_hdbc1, (BYTE *) w_street_2, 0, ADDRESS_LEN, NULL, 0, 0, 4);
if (rc != SUCCEED)
    HandleErrorDBC(w_hdbc1);

rc = bcp_bind(w_hdbc1, (BYTE *) w_city, 0, ADDRESS_LEN, NULL, 0, 0, 5);
if (rc != SUCCEED)
    HandleErrorDBC(w_hdbc1);

rc = bcp_bind(w_hdbc1, (BYTE *) w_state, 0, STATE_LEN, NULL, 0, 0, 6);
if (rc != SUCCEED)
    HandleErrorDBC(w_hdbc1);

rc = bcp_bind(w_hdbc1, (BYTE *) w_zip, 0, ZIP_LEN, NULL, 0, 0, 7);
if (rc != SUCCEED)
    HandleErrorDBC(w_hdbc1);

8);
rc = bcp_bind(w_hdbc1, (BYTE *) &w_tax, 0, SQL_VARLEN_DATA, NULL, 0, SQLFLT8,
if (rc != SUCCEED)
    HandleErrorDBC(w_hdbc1);
```

```
9);
rc = bcp_bind(w_hdbc1, (BYTE *) &w_ytd, 0, SQL_VARLEN_DATA, NULL, 0, SQLFLT8,
if (rc != SUCCEED)
    HandleErrorDBC(w_hdbc1);

time_start = (TimeNow() / MILLI);

warehouse_rows_loaded = 0;

for (w_id = (short)aptr->starting_warehouse; w_id <= aptr->num_warehouses;
w_id++)
{
    MakeAlphaString(6,10, W_NAME_LEN, w_name);
    MakeAddress(w_street_1, w_street_2, w_city, w_state, w_zip);
    w_tax = ((float) RandomNumber(0L,2000L))/10000.00;
    w_ytd = 300000.00;

    rc = bcp_sendrow(w_hdbc1);
    if (rc != SUCCEED)
        HandleErrorDBC(w_hdbc1);

    warehouse_rows_loaded++;
    CheckForCommit(w_hdbc1, i_hstmt1, warehouse_rows_loaded, "warehouse",
&time_start);
}

rcint = bcp_done(w_hdbc1);
if (rcint < 0)
    HandleErrorDBC(w_hdbc1);

printf("Finished loading warehouse table.\n");

// if build index after load...
if ((aptr->build_index == 1) && (aptr->index_order == 0))
    BuildIndex("idxwarcl");

stock_rows_loaded = 0;
district_rows_loaded = 0;

District();
Stock();

}

//=====
//
// Function : District
//
//=====

void District()
{
    short d_id;
    short d_w_id;
    char d_name[D_NAME_LEN+1];
    char d_street_1[ADDRESS_LEN+1];
    char d_street_2[ADDRESS_LEN+1];
    char d_city[ADDRESS_LEN+1];
```

## Appendix B - Database Design

```
char d_state[STATE_LEN+1];
char d_zip[ZIP_LEN+1];
double d_tax;
double d_ytd;
char name[20];
long d_next_o_id;
long time_start;
int w_id;
RETCODE rc;
DBINT rcint;
char bcp hint[128];

// Seed with unique number
seed(4);

printf("Loading district table...\n");

// build index before load
if ((aptr->build_index == 1) && (aptr->index_order == 1))
    BuildIndex("idxdiscl");

InitString(d_name, D_NAME_LEN+1);
InitAddress(d_street_1, d_street_2, d_city, d_state, d_zip);
sprintf(name, "%s.%s", aptr->database, "district");

rc = bcp_init(w_hdbc1, name, NULL, "logs\\district.err", DB_IN);
if (rc != SUCCEED)
    HandleErrorDBC(w_hdbc1);

if ((aptr->build_index == 1) && (aptr->index_order == 1))
{
    sprintf(bcp hint, "tablock, order (d_w_id, d_id), ROWS_PER_BATCH =
%u", (aptr->num_warehouses * 10));
    rc = bcp_control(w_hdbc1, BCPHINTS, (void*) bcp hint);
    if (rc != SUCCEED)
        HandleErrorDBC(w_hdbc1);
}

1); rc = bcp_bind(w_hdbc1, (BYTE *) &d_id, 0, SQL_VARLEN_DATA, NULL, 0, SQLINT2,
if (rc != SUCCEED)
    HandleErrorDBC(w_hdbc1);

2); rc = bcp_bind(w_hdbc1, (BYTE *) &d_w_id, 0, SQL_VARLEN_DATA, NULL, 0, SQLINT2,
if (rc != SUCCEED)
    HandleErrorDBC(w_hdbc1);

rc = bcp_bind(w_hdbc1, (BYTE *) d_name, 0, D_NAME_LEN, NULL, 0, 0, 3);
if (rc != SUCCEED)
    HandleErrorDBC(w_hdbc1);

rc = bcp_bind(w_hdbc1, (BYTE *) d_street_1, 0, ADDRESS_LEN, NULL, 0, 0, 4);
if (rc != SUCCEED)
    HandleErrorDBC(w_hdbc1);

rc = bcp_bind(w_hdbc1, (BYTE *) d_street_2, 0, ADDRESS_LEN, NULL, 0, 0, 5);
if (rc != SUCCEED)
    HandleErrorDBC(w_hdbc1);

rc = bcp_bind(w_hdbc1, (BYTE *) d_city, 0, ADDRESS_LEN, NULL, 0, 0, 6);
if (rc != SUCCEED)
    HandleErrorDBC(w_hdbc1);
```

```
rc = bcp_bind(w_hdbc1, (BYTE *) d_state, 0, STATE_LEN, NULL, 0, 0, 7);
if (rc != SUCCEED)
    HandleErrorDBC(w_hdbc1);

rc = bcp_bind(w_hdbc1, (BYTE *) d_zip, 0, ZIP_LEN, NULL, 0, 0, 8);
if (rc != SUCCEED)
    HandleErrorDBC(w_hdbc1);

9); rc = bcp_bind(w_hdbc1, (BYTE *) &d_tax, 0, SQL_VARLEN_DATA, NULL, 0, SQLFLT8,
if (rc != SUCCEED)
    HandleErrorDBC(w_hdbc1);

10); rc = bcp_bind(w_hdbc1, (BYTE *) &d_ytd, 0, SQL_VARLEN_DATA, NULL, 0, SQLFLT8,
if (rc != SUCCEED)
    HandleErrorDBC(w_hdbc1);

SQLINT4, 11); rc = bcp_bind(w_hdbc1, (BYTE *) &d_next_o_id, 0, SQL_VARLEN_DATA, NULL, 0,
if (rc != SUCCEED)
    HandleErrorDBC(w_hdbc1);

d_ytd = 30000.0;
d_next_o_id = orders_per_district+1;
time_start = (TimeNow() / MILLI);

for (w_id = aptr->starting_warehouse; w_id <= aptr->num_warehouses; w_id++)
{
    d_w_id = w_id;
    for (d_id = 1; d_id <= DISTRICT_PER_WAREHOUSE; d_id++)
    {
        MakeAlphaString(6,10,D_NAME_LEN, d_name);
        MakeAddress(d_street_1, d_street_2, d_city, d_state,
        d_tax = ((float) RandomNumber(0L,2000L))/10000.00;
        rc = bcp_sendrow(w_hdbc1);
        if (rc != SUCCEED)
            HandleErrorDBC(w_hdbc1);
        district_rows_loaded++;
        CheckForCommit(w_hdbc1, w_hstmt1, district_rows_loaded,
        "district", &time_start);
    }
}

rcint = bcp_done(w_hdbc1);
if (rcint < 0)
    HandleErrorDBC(w_hdbc1);

printf("Finished loading district table.\n");

// if build index after load...
if ((aptr->build_index == 1) && (aptr->index_order == 0))
    BuildIndex("idxdiscl");
```

## Appendix B - Database Design

```
    return;
}

//=====
//
// Function   : Stock
//
//=====

void Stock()
{
    long s_i_id;
    short s_w_id;
    short s_quantity;
    char s_dist_01[S_DIST_LEN+1];
    char s_dist_02[S_DIST_LEN+1];
    char s_dist_03[S_DIST_LEN+1];
    char s_dist_04[S_DIST_LEN+1];
    char s_dist_05[S_DIST_LEN+1];
    char s_dist_06[S_DIST_LEN+1];
    char s_dist_07[S_DIST_LEN+1];
    char s_dist_08[S_DIST_LEN+1];
    char s_dist_09[S_DIST_LEN+1];
    char s_dist_10[S_DIST_LEN+1];
    long s_ytd;
    short s_order_cnt;
    short s_remote_cnt;
    char s_data[S_DATA_LEN+1];
    short len;
    char name[20];
    long time_start;
    RETCODE rc;
    DBINT rcint;
    char bcp[128];

    // Seed with unique number
    seed(3);

    // if build index before load...
    if ((aptr->build_index == 1) && (aptr->index_order == 1))
        BuildIndex("idxstkcl");

    sprintf(name, "%s.%s", aptr->database, "stock");

    rc = bcp_init(w_hdbc1, name, NULL, "logs\\stock.err", DB_IN);
    if (rc != SUCCEED)
        HandleErrorDBC(w_hdbc1);

    if ((aptr->build_index == 1) && (aptr->index_order == 1))
    {
        sprintf(bcp, "tablock, order (s_i_id, s_w_id), ROWS_PER_BATCH =
%u", (aptr->num_warehouses * 100000));
        rc = bcp_control(w_hdbc1, BCPHINTS, (void*) bcp);
        if (rc != SUCCEED)
            HandleErrorDBC(w_hdbc1);
    }

    rc = bcp_bind(w_hdbc1, (BYTE *) &s_i_id, 0, SQL_VARLEN_DATA, NULL, 0, SQLINT4,
1);
    if (rc != SUCCEED)
        HandleErrorDBC(w_hdbc1);
```

```
        bcp_bind(w_hdbc1, (BYTE *) &s_w_id, 0, SQL_VARLEN_DATA, NULL, 0, SQLINT2, 2);
        if (rc != SUCCEED)
            HandleErrorDBC(w_hdbc1);

        rc = bcp_bind(w_hdbc1, (BYTE *) &s_quantity, 0, SQL_VARLEN_DATA, NULL, 0,
SQLINT2, 3);
        if (rc != SUCCEED)
            HandleErrorDBC(w_hdbc1);

        rc = bcp_bind(w_hdbc1, (BYTE *) s_dist_01, 0, S_DIST_LEN, NULL, 0, 0, 4);
        if (rc != SUCCEED)
            HandleErrorDBC(w_hdbc1);

        rc = bcp_bind(w_hdbc1, (BYTE *) s_dist_02, 0, S_DIST_LEN, NULL, 0, 0, 5);
        if (rc != SUCCEED)
            HandleErrorDBC(w_hdbc1);

        rc = bcp_bind(w_hdbc1, (BYTE *) s_dist_03, 0, S_DIST_LEN, NULL, 0, 0, 6);
        if (rc != SUCCEED)
            HandleErrorDBC(w_hdbc1);

        rc = bcp_bind(w_hdbc1, (BYTE *) s_dist_04, 0, S_DIST_LEN, NULL, 0, 0, 7);
        if (rc != SUCCEED)
            HandleErrorDBC(w_hdbc1);

        rc = bcp_bind(w_hdbc1, (BYTE *) s_dist_05, 0, S_DIST_LEN, NULL, 0, 0, 8);
        if (rc != SUCCEED)
            HandleErrorDBC(w_hdbc1);

        rc = bcp_bind(w_hdbc1, (BYTE *) s_dist_06, 0, S_DIST_LEN, NULL, 0, 0, 9);
        if (rc != SUCCEED)
            HandleErrorDBC(w_hdbc1);

        rc = bcp_bind(w_hdbc1, (BYTE *) s_dist_07, 0, S_DIST_LEN, NULL, 0, 0, 10);
        if (rc != SUCCEED)
            HandleErrorDBC(w_hdbc1);

        rc = bcp_bind(w_hdbc1, (BYTE *) s_dist_08, 0, S_DIST_LEN, NULL, 0, 0, 11);
        if (rc != SUCCEED)
            HandleErrorDBC(w_hdbc1);

        rc = bcp_bind(w_hdbc1, (BYTE *) s_dist_09, 0, S_DIST_LEN, NULL, 0, 0, 12);
        if (rc != SUCCEED)
            HandleErrorDBC(w_hdbc1);

        rc = bcp_bind(w_hdbc1, (BYTE *) s_dist_10, 0, S_DIST_LEN, NULL, 0, 0, 13);
        if (rc != SUCCEED)
            HandleErrorDBC(w_hdbc1);

        rc = bcp_bind(w_hdbc1, (BYTE *) &s_ytd, 0, SQL_VARLEN_DATA, NULL, 0, SQLINT4,
14);
        if (rc != SUCCEED)
            HandleErrorDBC(w_hdbc1);

        rc = bcp_bind(w_hdbc1, (BYTE *) &s_order_cnt, 0, SQL_VARLEN_DATA, NULL, 0,
SQLINT2, 15);
        if (rc != SUCCEED)
            HandleErrorDBC(w_hdbc1);

        rc = bcp_bind(w_hdbc1, (BYTE *) &s_remote_cnt, 0, SQL_VARLEN_DATA, NULL, 0,
SQLINT2, 16);
        if (rc != SUCCEED)
            HandleErrorDBC(w_hdbc1);
```

## Appendix B - Database Design

```
rc = bcp_bind(w_hdbc1, (BYTE *) s_data, 0, S_DATA_LEN, NULL, 0, 0, 17);
if (rc != SUCCEED)
    HandleErrorDBC(w_hdbc1);

s_ytd = s_order_cnt = s_remote_cnt = 0;

time_start = (TimeNow() / MILLI);

printf("...Loading stock table\n");

for (s_i_id=1; s_i_id <= max_items; s_i_id++)
{
    for (s_w_id = (short)aptr->starting_warehouse; s_w_id <= aptr-
>num_warehouses; s_w_id++)
    {
        s_quantity = (short)RandomNumber(10L,100L);
        len = MakeAlphaString(24,24,S_DIST_LEN, s_dist_01);
        len = MakeAlphaString(24,24,S_DIST_LEN, s_dist_02);
        len = MakeAlphaString(24,24,S_DIST_LEN, s_dist_03);
        len = MakeAlphaString(24,24,S_DIST_LEN, s_dist_04);
        len = MakeAlphaString(24,24,S_DIST_LEN, s_dist_05);
        len = MakeAlphaString(24,24,S_DIST_LEN, s_dist_06);
        len = MakeAlphaString(24,24,S_DIST_LEN, s_dist_07);
        len = MakeAlphaString(24,24,S_DIST_LEN, s_dist_08);
        len = MakeAlphaString(24,24,S_DIST_LEN, s_dist_09);
        len = MakeAlphaString(24,24,S_DIST_LEN, s_dist_10);

        len = MakeOriginalAlphaString(26,50, S_DATA_LEN,
s_data,10);

        rc = bcp_sendrow(w_hdbc1);
        if (rc != SUCCEED)
            HandleErrorDBC(w_hdbc1);

        stock_rows_loaded++;
        CheckForCommit(w_hdbc1, w_hstmt1, stock_rows_loaded,
"stock", &time_start);
    }
}

rcint = bcp_done(w_hdbc1);
if (rcint < 0)
    HandleErrorDBC(w_hdbc1);

printf("Finished loading stock table.\n");

SQLFreeStmt(w_hstmt1, SQL_DROP);
SQLDisconnect(w_hdbc1);
SQLFreeConnect(w_hdbc1);

// if build index after load..
if ((aptr->build_index == 1) && (aptr->index_order == 0))
    BuildIndex("idxstkcl");

return;
}

//=====
```

```
//
// Function : LoadCustomer
//
//=====

void LoadCustomer()
{
    LOADER_TIME_STRUCT customer_time_start;
    LOADER_TIME_STRUCT history_time_start;
    short w_id;
    short d_id;
    DWORD dwThreadId[MAX_CUSTOMER_THREADS];
    HANDLE hThread[MAX_CUSTOMER_THREADS];
    char name[20];
    RETCODE rc;
    DBINT rcint;
    char bcphint[128];
    char cmd[256];
    char rc_l;
    // SQLRETURN // SQLSMALLINT // SQLCHAR // SQLINTEGER
    Msg[SQL_MAX_MESSAGE_LENGTH]; // NativeError;

    // Seed with unique number
    seed(5);

    printf("Loading customer and history tables...\n");

    // if build index before load..
    if ((aptr->build_index == 1) && (aptr->index_order == 1))
        BuildIndex("idxcuscl");

    // Initialize bulk copy
    sprintf(name, "%s.%s", aptr->database, "customer");

    rc = bcp_init(c_hdbc1, name, NULL, "logs\\customer.err", DB_IN);
    if (rc != SUCCEED)
        HandleErrorDBC(c_hdbc1);

    if ((aptr->build_index == 1) && (aptr->index_order == 1))
    {
        sprintf(bcphint, "tablock, order (c_w_id, c_d_id, c_id),
ROWS_PER_BATCH = %u", (aptr->num_warehouses * 30000));
        rc = bcp_control(c_hdbc1, BCPHINTS, (void*) bcphint);
        if (rc != SUCCEED)
            HandleErrorDBC(c_hdbc1);
    }

    sprintf(name, "%s.%s", aptr->database, "history");

    rc = bcp_init(c_hdbc2, name, NULL, "logs\\history.err", DB_IN);
    if (rc != SUCCEED)
        HandleErrorDBC(c_hdbc2);

    sprintf(bcphint, "tablock");
    rc = bcp_control(c_hdbc2, BCPHINTS, (void*) bcphint);
    if (rc != SUCCEED)
        HandleErrorDBC(c_hdbc2);

    customer_rows_loaded = 0;
    history_rows_loaded = 0;
}
```

## Appendix B - Database Design

```
CustomerBufInit();

customer_time_start.time_start = (TimeNow() / MILLI);
history_time_start.time_start = (TimeNow() / MILLI);

for (w_id = (short)aptr->starting_warehouse; w_id <= aptr->num_warehouses;
w_id++)
{
    for (d_id = 1; d_id <= DISTRICT_PER_WAREHOUSE; d_id++)
    {
        CustomerBufLoad(d_id, w_id);
        // Start parallel loading threads here...
        // Start customer table thread
        printf("...Loading customer table for: d_id = %d, w_id =
%d\n", d_id, w_id);

        hThread[0] = CreateThread(NULL,
0,
(LPTHREAD_START_ROUTINE) LoadCustomerTable,
&customer_time_start,
0,
&dwThreadID[0]);

        if (hThread[0] == NULL)
        {
            printf("Error, failed in creating creating thread
= 0.\n");
            exit(-1);
        }
        // Start History table thread
        printf("...Loading history table for: d_id = %d, w_id =
%d\n", d_id, w_id);

        hThread[1] = CreateThread(NULL,
0,
(LPTHREAD_START_ROUTINE) LoadHistoryTable,
&history_time_start,
0,
&dwThreadID[1]);

        if (hThread[1] == NULL)
        {
            printf("Error, failed in creating creating thread
= 1.\n");
            exit(-1);
        }
    }
}
```

```
WaitForSingleObject( hThread[0], INFINITE );
WaitForSingleObject( hThread[1], INFINITE );

if (CloseHandle(hThread[0]) == FALSE)
{
    printf("Error, failed in closing customer thread
handle with errno: %d\n", GetLastError());
}

if (CloseHandle(hThread[1]) == FALSE)
{
    printf("Error, failed in closing history thread
handle with errno: %d\n", GetLastError());
}

}

// flush the bulk connection
rcint = bcp_done(c_hdbc1);
if (rcint < 0)
    HandleErrorDBC(c_hdbc1);

rcint = bcp_done(c_hdbc2);
if (rcint < 0)
    HandleErrorDBC(c_hdbc2);

printf("Finished loading customer table.\n");

// if build index after load...
if ((aptr->build_index == 1) && (aptr->index_order == 0))
    BuildIndex("idxcuscl");

// build non-clustered index
if (aptr->build_index == 1)
    BuildIndex("idxcusnc");

// Output the NURAND used for the loader into C_FIRST for C_ID = 1,
// C_W_ID = 1, and C_D_ID = 1
sprintf(cmd, "isql -S%s -U%s -P%s -d%s -e -Q\"update customer set c_first =
'C_LOAD = %d' where c_id = 1 and c_w_id = 1 and c_d_id = 1\" > logs\\nurand_load.log",
aptr->server,
aptr->user,
aptr->password,
aptr->database,
LOADER_NURAND_C);

system(cmd);

SQLFreeStmt(c_hstmt1, SQL_DROP);
SQLDisconnect(c_hdbc1);
SQLFreeConnect(c_hdbc1);

SQLFreeStmt(c_hstmt2, SQL_DROP);
SQLDisconnect(c_hdbc2);
SQLFreeConnect(c_hdbc2);

return;
}
```

## Appendix B - Database Design

```
//=====
//
// Function   : CustomerBufInit
//
//=====

void CustomerBufInit()
{
    int    i;

    for (i=0;i<customers_per_district;i++)
    {
        customer_buf[i].c_id = 0;
        customer_buf[i].c_d_id = 0;
        customer_buf[i].c_w_id = 0;

        strcpy(customer_buf[i].c_first,"");
        strcpy(customer_buf[i].c_middle,"");
        strcpy(customer_buf[i].c_last,"");
        strcpy(customer_buf[i].c_street_1,"");
        strcpy(customer_buf[i].c_street_2,"");
        strcpy(customer_buf[i].c_city,"");
        strcpy(customer_buf[i].c_state,"");
        strcpy(customer_buf[i].c_zip,"");
        strcpy(customer_buf[i].c_phone,"");
        strcpy(customer_buf[i].c_credit,"");

        customer_buf[i].c_credit_lim = 0;
        customer_buf[i].c_discount = (float) 0;

        // fix to avoid ODBC float to numeric conversion problem.
        // customer_buf[i].c_balance = 0;
        strcpy(customer_buf[i].c_balance,"");

        customer_buf[i].c_ytd_payment = 0;
        customer_buf[i].c_payment_cnt = 0;
        customer_buf[i].c_delivery_cnt = 0;

        strcpy(customer_buf[i].c_data,"");

        customer_buf[i].h_amount = 0;

        strcpy(customer_buf[i].h_data,"");

    }
}

//=====
//
// Function   : CustomerBufLoad
//
// Fills shared buffer for HISTORY and CUSTOMER
//=====

void CustomerBufLoad(int d_id, int w_id)
{
    long          i;
    CUSTOMER_SORT_STRUCT  c[CUSTOMERS_PER_DISTRICT];
```

```
for (i=0;i<customers_per_district;i++)
{
    if (i < 1000)
        LastName(i, c[i].c_last);
    else
        LastName(NURand(255,0,999,LOADER_NURAND_C), c[i].c_last);

    MakeAlphaString(8,16,FIRST_NAME_LEN, c[i].c_first);

    c[i].c_id = i+1;
}

printf("...Loading customer buffer for: d_id = %d, w_id = %d\n",
        d_id, w_id);

for (i=0;i<customers_per_district;i++)
{
    customer_buf[i].c_d_id = d_id;
    customer_buf[i].c_w_id = w_id;
    customer_buf[i].h_amount = 10.0;

    customer_buf[i].c_ytd_payment = 10.0;

    customer_buf[i].c_payment_cnt = 1;
    customer_buf[i].c_delivery_cnt = 0;

    // Generate CUSTOMER and HISTORY data

    customer_buf[i].c_id = c[i].c_id;

    strcpy(customer_buf[i].c_first, c[i].c_first);
    strcpy(customer_buf[i].c_last, c[i].c_last);

    customer_buf[i].c_middle[0] = 'O';
    customer_buf[i].c_middle[1] = 'E';

    MakeAddress(customer_buf[i].c_street_1,
                customer_buf[i].c_street_2,
                customer_buf[i].c_city,
                customer_buf[i].c_state,
                customer_buf[i].c_zip);

    MakeNumberString(16, 16, PHONE_LEN, customer_buf[i].c_phone);

    if (RandomNumber(1L, 100L) > 10)
        customer_buf[i].c_credit[0] = 'G';
    else
        customer_buf[i].c_credit[0] = 'B';
    customer_buf[i].c_credit[1] = 'C';

    customer_buf[i].c_credit_lim = 50000.0;
    customer_buf[i].c_discount = ((float) RandomNumber(0L, 5000L)) /
10000.0;

    // fix to avoid ODBC float to numeric conversion problem.
    // customer_buf[i].c_balance = -10.0;
    strcpy(customer_buf[i].c_balance,"-10.0");
```

## Appendix B - Database Design

```
        MakeAlphaString(500, 500, C_DATA_LEN, customer_buf[i].c_data);

        // Generate HISTORY data
        MakeAlphaString(12, 24, H_DATA_LEN, customer_buf[i].h_data);
    }
}

//=====
//
// Function   : LoadCustomerTable
//
//=====

void LoadCustomerTable(LOADER_TIME_STRUCT *customer_time_start)
{
    int         i;
    long        c_id;
    short       c_d_id;
    short       c_w_id;
    char        c_first[FIRST_NAME_LEN+1];
    char        c_middle[MIDDLE_NAME_LEN+1];
    char        c_last[LAST_NAME_LEN+1];
    char        c_street_1[ADDRESS_LEN+1];
    char        c_street_2[ADDRESS_LEN+1];
    char        c_city[ADDRESS_LEN+1];
    char        c_state[STATE_LEN+1];
    char        c_zip[ZIP_LEN+1];
    char        c_phone[PHONE_LEN+1];
    char        c_credit[CREDIT_LEN+1];
    double      c_credit_lim;
    double      c_discount;

    // fix to avoid ODBC float to numeric conversion problem.
    // double      c_balance;
    char        c_balance[6];

    double      c_ytd_payment;
    short       c_payment_cnt;
    short       c_delivery_cnt;
    char        c_data[C_DATA_LEN+1];
    char        c_since[C_SINCE_LEN+1];
    RETCODE     rc;

    rc = bcp_bind(c_hdbc1, (BYTE *) &c_id, 0, SQL_VARLEN_DATA, NULL, 0, SQLINT4, 1);
    if (rc != SUCCEED)
        HandleErrorDBC(c_hdbc1);

    rc = bcp_bind(c_hdbc1, (BYTE *) &c_d_id, 0, SQL_VARLEN_DATA, NULL, 0, SQLINT2, 2);
    if (rc != SUCCEED)
        HandleErrorDBC(c_hdbc1);

    rc = bcp_bind(c_hdbc1, (BYTE *) &c_w_id, 0, SQL_VARLEN_DATA, NULL, 0, SQLINT2,
3);
    if (rc != SUCCEED)
        HandleErrorDBC(c_hdbc1);

    rc = bcp_bind(c_hdbc1, (BYTE *) c_first, 0, FIRST_NAME_LEN, NULL, 0, 0, 4);
    if (rc != SUCCEED)
        HandleErrorDBC(c_hdbc1);

    rc = bcp_bind(c_hdbc1, (BYTE *) c_middle, 0, MIDDLE_NAME_LEN, NULL, 0, 0, 5);
```

```
    if (rc != SUCCEED)
        HandleErrorDBC(c_hdbc1);

    rc = bcp_bind(c_hdbc1, (BYTE *) c_last, 0, LAST_NAME_LEN, NULL, 0, 0, 6);
    if (rc != SUCCEED)
        HandleErrorDBC(c_hdbc1);

    rc = bcp_bind(c_hdbc1, (BYTE *) c_street_1, 0, ADDRESS_LEN, NULL, 0, 0, 7);
    if (rc != SUCCEED)
        HandleErrorDBC(c_hdbc1);

    rc = bcp_bind(c_hdbc1, (BYTE *) c_street_2, 0, ADDRESS_LEN, NULL, 0, 0, 8);
    if (rc != SUCCEED)
        HandleErrorDBC(c_hdbc1);

    rc = bcp_bind(c_hdbc1, (BYTE *) c_city, 0, ADDRESS_LEN, NULL, 0, 0, 9);
    if (rc != SUCCEED)
        HandleErrorDBC(c_hdbc1);

    rc = bcp_bind(c_hdbc1, (BYTE *) c_state, 0, STATE_LEN, NULL, 0, 0, 10);
    if (rc != SUCCEED)
        HandleErrorDBC(c_hdbc1);

    rc = bcp_bind(c_hdbc1, (BYTE *) c_zip, 0, ZIP_LEN, NULL, 0, 0, 11);
    if (rc != SUCCEED)
        HandleErrorDBC(c_hdbc1);

    rc = bcp_bind(c_hdbc1, (BYTE *) c_phone, 0, PHONE_LEN, NULL, 0, 0, 12);
    if (rc != SUCCEED)
        HandleErrorDBC(c_hdbc1);

    rc = bcp_bind(c_hdbc1, (BYTE *) &c_since, 0, C_SINCE_LEN, NULL, 0,
SQLCHARACTER, 13);
    if (rc != SUCCEED)
        HandleErrorDBC(c_hdbc1);

    rc = bcp_bind(c_hdbc1, (BYTE *) c_credit, 0, CREDIT_LEN, NULL, 0, 0, 14);
    if (rc != SUCCEED)
        HandleErrorDBC(c_hdbc1);

    rc = bcp_bind(c_hdbc1, (BYTE *) &c_credit_lim, 0, SQL_VARLEN_DATA, NULL, 0, SQLFLT8,
15);
    if (rc != SUCCEED)
        HandleErrorDBC(c_hdbc1);

    rc = bcp_bind(c_hdbc1, (BYTE *) &c_discount, 0, SQL_VARLEN_DATA, NULL, 0, SQLFLT8,
16);
    if (rc != SUCCEED)
        HandleErrorDBC(c_hdbc1);

    // fix to avoid ODBC float to numeric conversion problem.
    // rc = bcp_bind(c_hdbc1, (BYTE *) &c_balance, 0, SQL_VARLEN_DATA, NULL, 0, SQLFLT8,
17);
    // if (rc != SUCCEED)
    //     HandleErrorDBC(c_hdbc1);
    rc = bcp_bind(c_hdbc1, (BYTE *) c_balance, 0, 5, NULL, 0, SQLCHARACTER, 17);
    if (rc != SUCCEED)
        HandleErrorDBC(c_hdbc1);

    rc = bcp_bind(c_hdbc1, (BYTE *) &c_ytd_payment, 0, SQL_VARLEN_DATA, NULL, 0, SQLFLT8,
18);
```

## Appendix B - Database Design

```
        if (rc != SUCCEEDED)
            HandleErrorDBC(c_hdbc1);

    rc = bcp_bind(c_hdbc1, (BYTE *) &c_payment_cnt, 0, SQL_VARLEN_DATA, NULL, 0, SQLINT2,
19);
    if (rc != SUCCEEDED)
        HandleErrorDBC(c_hdbc1);

    rc = bcp_bind(c_hdbc1, (BYTE *) &c_delivery_cnt, 0, SQL_VARLEN_DATA, NULL, 0, SQLINT2,
20);
    if (rc != SUCCEEDED)
        HandleErrorDBC(c_hdbc1);

    rc = bcp_bind(c_hdbc1, (BYTE *) c_data, 0, 500, NULL, 0, 0, 21);
    if (rc != SUCCEEDED)
        HandleErrorDBC(c_hdbc1);

    for (i = 0; i < customers_per_district; i++)
    {
        c_id = customer_buf[i].c_id;
        c_d_id = customer_buf[i].c_d_id;
        c_w_id = customer_buf[i].c_w_id;

        strcpy(c_first, customer_buf[i].c_first);
        strcpy(c_middle, customer_buf[i].c_middle);
        strcpy(c_last, customer_buf[i].c_last);
        strcpy(c_street_1, customer_buf[i].c_street_1);
        strcpy(c_street_2, customer_buf[i].c_street_2);
        strcpy(c_city, customer_buf[i].c_city);
        strcpy(c_state, customer_buf[i].c_state);
        strcpy(c_zip, customer_buf[i].c_zip);
        strcpy(c_phone, customer_buf[i].c_phone);
        strcpy(c_credit, customer_buf[i].c_credit);

        FormatDate(&c_since);

        c_credit_lim = customer_buf[i].c_credit_lim;
        c_discount = customer_buf[i].c_discount;

        // fix to avoid ODBC float to numeric conversion problem.

        // c_balance = customer_buf[i].c_balance;
        strcpy(c_balance, customer_buf[i].c_balance);

        c_ytd_payment = customer_buf[i].c_ytd_payment;
        c_payment_cnt = customer_buf[i].c_payment_cnt;
        c_delivery_cnt = customer_buf[i].c_delivery_cnt;

        strcpy(c_data, customer_buf[i].c_data);

        // Send data to server
        rc = bcp_sendrow(c_hdbc1);
        if (rc != SUCCEEDED)
            HandleErrorDBC(c_hdbc1);

        customer_rows_loaded++;
        CheckForCommit(c_hdbc1, c_hstmt1, customer_rows_loaded, "customer",
&customer_time_start->time_start);
    }
}
```

```
//=====================================================
//
// Function   : LoadHistoryTable
//
//=====================================================

void LoadHistoryTable(LOADER_TIME_STRUCT *history_time_start)
{
    int         i;
    long        c_id;
    short       c_d_id;
    short       c_w_id;
    double      h_amount;
    char        h_data[H_DATA_LEN+1];
    char        h_date[H_DATE_LEN+1];
    RETCODE     rc;

    rc = bcp_bind(c_hdbc2, (BYTE *) &c_id, 0, SQL_VARLEN_DATA, NULL, 0, SQLINT4, 1);
    if (rc != SUCCEEDED)
        HandleErrorDBC(c_hdbc2);

    rc = bcp_bind(c_hdbc2, (BYTE *) &c_d_id, 0, SQL_VARLEN_DATA, NULL, 0, SQLINT2, 2);
    if (rc != SUCCEEDED)
        HandleErrorDBC(c_hdbc2);

    rc = bcp_bind(c_hdbc2, (BYTE *) &c_w_id, 0, SQL_VARLEN_DATA, NULL, 0, SQLINT2, 3);
    if (rc != SUCCEEDED)
        HandleErrorDBC(c_hdbc2);

    rc = bcp_bind(c_hdbc2, (BYTE *) &c_d_id, 0, SQL_VARLEN_DATA, NULL, 0, SQLINT2, 4);
    if (rc != SUCCEEDED)
        HandleErrorDBC(c_hdbc2);

    rc = bcp_bind(c_hdbc2, (BYTE *) &c_w_id, 0, SQL_VARLEN_DATA, NULL, 0, SQLINT2, 5);
    if (rc != SUCCEEDED)
        HandleErrorDBC(c_hdbc2);

    rc = bcp_bind(c_hdbc2, (BYTE *) &h_date, 0, H_DATE_LEN, NULL, 0, SQLCHARACTER,
6);
    if (rc != SUCCEEDED)
        HandleErrorDBC(c_hdbc2);

    rc = bcp_bind(c_hdbc2, (BYTE *) &h_amount, 0, SQL_VARLEN_DATA, NULL, 0, SQLFLT8, 7);
    if (rc != SUCCEEDED)
        HandleErrorDBC(c_hdbc2);

    rc = bcp_bind(c_hdbc2, (BYTE *) h_data, 0, H_DATA_LEN, NULL, 0, 0, 8);
    if (rc != SUCCEEDED)
        HandleErrorDBC(c_hdbc2);

    for (i = 0; i < customers_per_district; i++)
    {
        c_id = customer_buf[i].c_id;
        c_d_id = customer_buf[i].c_d_id;
        c_w_id = customer_buf[i].c_w_id;
        h_amount = customer_buf[i].h_amount;
        strcpy(h_data, customer_buf[i].h_data);

        FormatDate(&h_date);

        // send to server
        rc = bcp_sendrow(c_hdbc2);
        if (rc != SUCCEEDED)

```

## Appendix B - Database Design

```
        HandleErrorDBC(o_hdbc2);

        history_rows_loaded++;
        CheckForCommit(c_hdbc2, c_hstmt2, history_rows_loaded, "history",
&history_time_start->time_start);
    }
}

//=====
//
// Function   : LoadOrders
//
//=====

void LoadOrders()
{
    LOADER_TIME_STRUCT    orders_time_start;
    LOADER_TIME_STRUCT    new_order_time_start;
    LOADER_TIME_STRUCT    order_line_time_start;
    short                 w_id;
    short                 d_id;
    DWORD                 dwThreadID[MAX_ORDER_THREADS];
    HANDLE                 hThread[MAX_ORDER_THREADS];
    char                  name[20];
    RETCODE                rc;
    char                  bcphint[128];

    // seed with unique number
    seed(6);

    printf("Loading orders...\n");

    // if build index before load...
    if ((aptr->build_index == 1) && (aptr->index_order == 1))
    {
        BuildIndex("idxordcl");
        BuildIndex("idxnodcl");
        BuildIndex("idxodlcl");
    }

    // initialize bulk copy
    sprintf(name, "%s.%s", aptr->database, "orders");

    rc = bcp_init(o_hdbc1, name, NULL, "logs\\orders.err", DB_IN);
    if (rc != SUCCEED)
        HandleErrorDBC(o_hdbc1);

    if ((aptr->build_index == 1) && (aptr->index_order == 1))
    {
        sprintf(bcphint, "tablock, order (o_w_id, o_d_id, o_id),
ROWS_PER_BATCH = %u", (aptr->num_warehouses * 30000));
        rc = bcp_control(o_hdbc1, BCPHINTS, (void*) bcphint);
        if (rc != SUCCEED)
            HandleErrorDBC(o_hdbc1);
    }

    sprintf(name, "%s.%s", aptr->database, "new_order");

    rc = bcp_init(o_hdbc2, name, NULL, "logs\\neword.err", DB_IN);
    if (rc != SUCCEED)
        HandleErrorDBC(o_hdbc2);
```

```
        if ((aptr->build_index == 1) && (aptr->index_order == 1))
        {
            sprintf(bcphint, "tablock, order (no_w_id, no_d_id, no_o_id),
ROWS_PER_BATCH = %u", (aptr->num_warehouses * 9000));
            rc = bcp_control(o_hdbc2, BCPHINTS, (void*) bcphint);
            if (rc != SUCCEED)
                HandleErrorDBC(o_hdbc2);
        }

        sprintf(name, "%s.%s", aptr->database, "order_line");

        rc = bcp_init(o_hdbc3, name, NULL, "logs\\ordline.err", DB_IN);
        if (rc != SUCCEED)
            HandleErrorDBC(o_hdbc3);

        if ((aptr->build_index == 1) && (aptr->index_order == 1))
        {
            sprintf(bcphint, "tablock, order (ol_w_id, ol_d_id, ol_o_id,
ol_number), ROWS_PER_BATCH = %u", (aptr->num_warehouses * 300000));
            rc = bcp_control(o_hdbc3, BCPHINTS, (void*) bcphint);
            if (rc != SUCCEED)
                HandleErrorDBC(o_hdbc3);
        }

        orders_rows_loaded = 0;
        new_order_rows_loaded = 0;
        order_line_rows_loaded = 0;

        OrdersBufInit();

        orders_time_start.time_start = (TimeNow() / MILLI);
        new_order_time_start.time_start = (TimeNow() / MILLI);
        order_line_time_start.time_start = (TimeNow() / MILLI);

        for (w_id = (short)aptr->starting_warehouse; w_id <= aptr->num_warehouses;
w_id++)
        {
            for (d_id = 1; d_id <= DISTRICT_PER_WAREHOUSE; d_id++)
            {
                OrdersBufLoad(d_id, w_id);

                // start parallel loading threads here...

                // start Orders table thread
                printf("...Loading Order Table for: d_id = %d, w_id =
%d\n", d_id, w_id);

                hThread[0] = CreateThread(NULL,
0,
(LPTHREAD_START_ROUTINE) LoadOrdersTable,
&orders_time_start,
0,
&dwThreadID[0]);

                if (hThread[0] == NULL)
```

## Appendix B - Database Design

```
    {
        printf("Error, failed in creating creating thread
= 0.\n");
        exit(-1);
    }
    // start NewOrder table thread
    printf("...Loading New-Order Table for: d_id = %d, w_id =
%d\n", d_id, w_id);
    hThread[1] = CreateThread(NULL,
0,
(LPTHREAD_START_ROUTINE) LoadNewOrderTable,
&new_order_time_start,
0,
&dwThreadID[1]);
    if (hThread[1] == NULL)
    {
        printf("Error, failed in creating creating thread
= 1.\n");
        exit(-1);
    }
    // start Order-Line table thread
    printf("...Loading Order-Line Table for: d_id = %d, w_id =
%d\n", d_id, w_id);
    hThread[2] = CreateThread(NULL,
0,
(LPTHREAD_START_ROUTINE) LoadOrderLineTable,
&order_line_time_start,
0,
&dwThreadID[2]);
    if (hThread[2] == NULL)
    {
        printf("Error, failed in creating creating thread
= 2.\n");
        exit(-1);
    }
    WaitForSingleObject( hThread[0], INFINITE );
    WaitForSingleObject( hThread[1], INFINITE );
    WaitForSingleObject( hThread[2], INFINITE );
    if (CloseHandle(hThread[0]) == FALSE)
    {
        printf("Error, failed in closing Orders thread
handle with errno: %d\n", GetLastError());
    }
}
```

```
        if (CloseHandle(hThread[1]) == FALSE)
        {
            printf("Error, failed in closing NewOrder thread
handle with errno: %d\n", GetLastError());
        }
        if (CloseHandle(hThread[2]) == FALSE)
        {
            printf("Error, failed in closing OrderLine thread
handle with errno: %d\n", GetLastError());
        }
    }
    printf("Finished loading orders.\n");
}
return;
}
//=====
//
// Function   : OrdersBufInit
//
// Clears shared buffer for ORDERS, NEWORDER, and ORDERLINE
//
//=====
void OrdersBufInit()
{
    int    i;
    int    j;
    for (i=0;i<orders_per_district;i++)
    {
        orders_buf[i].o_id = 0;
        orders_buf[i].o_d_id = 0;
        orders_buf[i].o_w_id = 0;
        orders_buf[i].o_c_id = 0;
        orders_buf[i].o_carrier_id = 0;
        orders_buf[i].o_ol_cnt = 0;
        orders_buf[i].o_all_local = 0;
        for (j=0;j<=14;j++)
        {
            orders_buf[i].o_ol[j].ol = 0;
            orders_buf[i].o_ol[j].ol_i_id = 0;
            orders_buf[i].o_ol[j].ol_supply_w_id = 0;
            orders_buf[i].o_ol[j].ol_quantity = 0;
            orders_buf[i].o_ol[j].ol_amount = 0;
            strcpy(orders_buf[i].o_ol[j].ol_dist_info,"");
        }
    }
}
//=====
//
```

## Appendix B - Database Design

```
// Function : OrdersBufLoad
//
// Fills shared buffer for ORDERS, NEWORDER, and ORDERLINE
//
//=====
void OrdersBufLoad(int d_id, int w_id)
{
    int     cust[ORDERS_PER_DIST+1];
    long    o_id;
    short   ol;

    printf("...Loading Order Buffer for: d_id = %d, w_id = %d\n",
           d_id, w_id);

    GetPermutation(cust, ORDERS_PER_DIST);

    for (o_id=0;o_id<orders_per_district;o_id++)
    {
        // Generate ORDER and NEW-ORDER data

        orders_buf[o_id].o_d_id = d_id;
        orders_buf[o_id].o_w_id = w_id;
        orders_buf[o_id].o_id = o_id+1;
        orders_buf[o_id].o_c_id = cust[o_id+1];
        orders_buf[o_id].o_ol_cnt = (short)RandomNumber(5L, 15L);

        if (o_id < first_new_order)
        {
            orders_buf[o_id].o_carrier_id = (short)RandomNumber(1L,
10L);
            orders_buf[o_id].o_all_local = 1;
        }
        else
        {
            orders_buf[o_id].o_carrier_id = 0;
            orders_buf[o_id].o_all_local = 1;
        }

        for (ol=0; ol<orders_buf[o_id].o_ol_cnt; ol++)
        {
            orders_buf[o_id].o_ol[ol].ol = ol+1;
            orders_buf[o_id].o_ol[ol].ol_i_id = RandomNumber(1L,
max_items);
            orders_buf[o_id].o_ol[ol].ol_supply_w_id = w_id;
            orders_buf[o_id].o_ol[ol].ol_quantity = 5;
            MakeAlphaString(24, 24, OL_DIST_INFO_LEN,
&orders_buf[o_id].o_ol[ol].ol_dist_info);

            // Generate ORDER-LINE data
            if (o_id < first_new_order)
            {
                orders_buf[o_id].o_ol[ol].ol_amount = 0;
                // Added to insure ol_delivery_d set properly

                during load

                FormatDate(&orders_buf[o_id].o_ol[ol].ol_delivery_d);
            }
        }
    }
}
```

```
else
{
    orders_buf[o_id].o_ol[ol].ol_amount =
RandomNumber(1,999999)/100.0;
// Added to insure ol_delivery_d set properly
during load

// odbc datetime format

strcpy(orders_buf[o_id].o_ol[ol].ol_delivery_d,"1899-12-31 12:00:00.000");
}
}
}

//=====
//
// Function : LoadOrdersTable
//
//=====
void LoadOrdersTable(LOADER_TIME_STRUCT *orders_time_start)
{
    int     i;
    long    o_id;
    short   o_d_id;
    short   o_w_id;
    long    o_c_id;
    short   o_carrier_id;
    short   o_ol_cnt;
    short   o_all_local;
    char    o_entry_d[O_ENTRY_D_LEN+1];
    RETCODE rc;
    DBINT   rcint;

    // bind ORDER data
    rc = bcp_bind(o_hdbc1, (BYTE *) &o_id, 0, SQL_VARLEN_DATA, NULL, 0, SQLINT4, 1);
    if (rc != SUCCEED)
        HandleErrorDBC(o_hdbc1);

    rc = bcp_bind(o_hdbc1, (BYTE *) &o_d_id, 0, SQL_VARLEN_DATA, NULL, 0, SQLINT2, 2);
    if (rc != SUCCEED)
        HandleErrorDBC(o_hdbc1);

    rc = bcp_bind(o_hdbc1, (BYTE *) &o_w_id, 0, SQL_VARLEN_DATA, NULL, 0, SQLINT2, 3);
    if (rc != SUCCEED)
        HandleErrorDBC(o_hdbc1);

    rc = bcp_bind(o_hdbc1, (BYTE *) &o_c_id, 0, SQL_VARLEN_DATA, NULL, 0, SQLINT4, 4);
    if (rc != SUCCEED)
        HandleErrorDBC(o_hdbc1);

    rc = bcp_bind(o_hdbc1, (BYTE *) &o_entry_d, 0, O_ENTRY_D_LEN, NULL, 0,
SQLCHARACTER, 5);
    if (rc != SUCCEED)
        HandleErrorDBC(o_hdbc1);

    rc = bcp_bind(o_hdbc1, (BYTE *) &o_carrier_id, 0, SQL_VARLEN_DATA, NULL, 0, SQLINT2,
6);
    if (rc != SUCCEED)
        HandleErrorDBC(o_hdbc1);
}
```

## Appendix B - Database Design

```
rc = bcp_bind(o_hdbc1, (BYTE *) &o_ol_cnt, 0, SQL_VARLEN_DATA, NULL, 0, SQLINT2, 7);
if (rc != SUCCEEDED)
    HandleErrorDBC(o_hdbc1);

rc = bcp_bind(o_hdbc1, (BYTE *) &o_all_local, 0, SQL_VARLEN_DATA, NULL, 0, SQLINT2,
8);
if (rc != SUCCEEDED)
    HandleErrorDBC(o_hdbc1);

for (i = 0; i < orders_per_district; i++)
{
    o_id      = orders_buf[i].o_id;
    o_d_id   = orders_buf[i].o_d_id;
    o_w_id   = orders_buf[i].o_w_id;
    o_c_id   = orders_buf[i].o_c_id;
    o_carrier_id = orders_buf[i].o_carrier_id;
    o_ol_cnt = orders_buf[i].o_ol_cnt;
    o_all_local = orders_buf[i].o_all_local;

    FormatDate(&o_entry_d);

    // send data to server
    rc = bcp_sendrow(o_hdbc1);
    if (rc != SUCCEEDED)
        HandleErrorDBC(o_hdbc1);

    orders_rows_loaded++;
    CheckForCommit(o_hdbc1, o_hstmt1, orders_rows_loaded, "orders",
&orders_time_start->time_start);
}

// rcint = bcp_batch(o_hdbc1);
// if (rcint < 0)
//     HandleErrorDBC(o_hdbc1);

if ((o_w_id == aptr->num_warehouses) && (o_d_id == 10))
{
    rcint = bcp_done(o_hdbc1);
    if (rcint < 0)
        HandleErrorDBC(o_hdbc1);

    SQLFreeStmt(o_hstmt1, SQL_DROP);
    SQLDisconnect(o_hdbc1);
    SQLFreeConnect(o_hdbc1);

    // if build index after load...
    if ((aptr->build_index == 1) && (aptr->index_order == 0))
        BuildIndex("idxordc1");

    // build non-clustered index
    if (aptr->build_index == 1)
        BuildIndex("idxordnc");
}

}

//=====
//
// Function   : LoadNewOrderTable
//
//=====
```

```
void LoadNewOrderTable(LOADER_TIME_STRUCT *new_order_time_start)
{
    int      i;
    long     o_id;
    short    o_d_id;
    short    o_w_id;

    RETCODE  rc;
    DBINT    rcint;

    // Bind NEW-ORDER data

    rc = bcp_bind(o_hdbc2, (BYTE *) &o_id, 0, SQL_VARLEN_DATA, NULL, 0, SQLINT4, 1);
    if (rc != SUCCEEDED)
        HandleErrorDBC(o_hdbc2);

    rc = bcp_bind(o_hdbc2, (BYTE *) &o_d_id, 0, SQL_VARLEN_DATA, NULL, 0, SQLINT2, 2);
    if (rc != SUCCEEDED)
        HandleErrorDBC(o_hdbc2);

    rc = bcp_bind(o_hdbc2, (BYTE *) &o_w_id, 0, SQL_VARLEN_DATA, NULL, 0, SQLINT2, 3);
    if (rc != SUCCEEDED)
        HandleErrorDBC(o_hdbc2);

    for (i = first_new_order; i < last_new_order; i++)
    {
        o_id = orders_buf[i].o_id;
        o_d_id = orders_buf[i].o_d_id;
        o_w_id = orders_buf[i].o_w_id;

        rc = bcp_sendrow(o_hdbc2);
        if (rc != SUCCEEDED)
            HandleErrorDBC(o_hdbc2);

        new_order_rows_loaded++;
        CheckForCommit(o_hdbc2, o_hstmt2, new_order_rows_loaded, "new_order",
&new_order_time_start->time_start);
    }

    // rcint = bcp_batch(o_hdbc2);
    // if (rcint < 0)
    //     HandleErrorDBC(o_hdbc2);

    if ((o_w_id == aptr->num_warehouses) && (o_d_id == 10))
    {
        rcint = bcp_done(o_hdbc2);
        if (rcint < 0)
            HandleErrorDBC(o_hdbc2);

        SQLFreeStmt(o_hstmt2, SQL_DROP);
        SQLDisconnect(o_hdbc2);
        SQLFreeConnect(o_hdbc2);

        // if build index after load...
        if ((aptr->build_index == 1) && (aptr->index_order == 0))
            BuildIndex("idxnodc1");
    }

}

//=====
```

## Appendix B - Database Design

```
//
// Function   : LoadOrderLineTable
//
//=====
void LoadOrderLineTable(LOADER_TIME_STRUCT *order_line_time_start)
{
    int          i,j;
    long         o_id;
    short        o_d_id;
    short        o_w_id;
    long         ol;
    long         ol_i_id;
    short        ol_supply_w_id;
    short        ol_quantity;
    double       ol_amount;
    char         ol_dist_info[DIST_INFO_LEN+1];
    char         ol_delivery_d[OL_DELIVERY_D_LEN+1];
    RETCODE      rc;
    DBINT        rcint;

    // bind ORDER-LINE data
    rc = bcp_bind(o_hdbc3, (BYTE *) &o_id, 0, SQL_VARLEN_DATA, NULL, 0, SQLINT4, 1);
    if (rc != SUCCEED)
        HandleErrorDBC(o_hdbc3);

    rc = bcp_bind(o_hdbc3, (BYTE *) &o_d_id, 0, SQL_VARLEN_DATA, NULL, 0, SQLINT2, 2);
    if (rc != SUCCEED)
        HandleErrorDBC(o_hdbc3);

    rc = bcp_bind(o_hdbc3, (BYTE *) &o_w_id, 0, SQL_VARLEN_DATA, NULL, 0, SQLINT2, 3);
    if (rc != SUCCEED)
        HandleErrorDBC(o_hdbc3);

    rc = bcp_bind(o_hdbc3, (BYTE *) &ol, 0, SQL_VARLEN_DATA, NULL, 0, SQLINT4, 4);
    if (rc != SUCCEED)
        HandleErrorDBC(o_hdbc3);

    rc = bcp_bind(o_hdbc3, (BYTE *) &ol_i_id, 0, SQL_VARLEN_DATA, NULL, 0, SQLINT4, 5);
    if (rc != SUCCEED)
        HandleErrorDBC(o_hdbc3);

    rc = bcp_bind(o_hdbc3, (BYTE *) &ol_supply_w_id, 0, SQL_VARLEN_DATA, NULL, 0,
SQLINT2, 6);
    if (rc != SUCCEED)
        HandleErrorDBC(o_hdbc3);

    rc = bcp_bind(o_hdbc3, (BYTE *) &ol_delivery_d, 0, OL_DELIVERY_D_LEN, NULL, 0,
SQLCHARACTER, 7);
    if (rc != SUCCEED)
        HandleErrorDBC(o_hdbc3);

    rc = bcp_bind(o_hdbc3, (BYTE *) &ol_quantity, 0, SQL_VARLEN_DATA, NULL, 0, SQLINT2,
8);
    if (rc != SUCCEED)
        HandleErrorDBC(o_hdbc3);

    rc = bcp_bind(o_hdbc3, (BYTE *) &ol_amount, 0, SQL_VARLEN_DATA, NULL, 0, SQLFLT8, 9);
    if (rc != SUCCEED)
        HandleErrorDBC(o_hdbc3);

    rc = bcp_bind(o_hdbc3, (BYTE *) ol_dist_info, 0, DIST_INFO_LEN, NULL, 0, 0, 10);
    if (rc != SUCCEED)
```

```
        HandleErrorDBC(o_hdbc3);

    for (i = 0; i < orders_per_district; i++)
    {
        o_id   = orders_buf[i].o_id;
        o_d_id = orders_buf[i].o_d_id;
        o_w_id = orders_buf[i].o_w_id;

        for (j=0; j < orders_buf[i].o_ol_cnt; j++)
        {
            ol         = orders_buf[i].o_ol[j].ol;
            ol_i_id   = orders_buf[i].o_ol[j].ol_i_id;
            ol_supply_w_id = orders_buf[i].o_ol[j].ol_supply_w_id;
            ol_quantity = orders_buf[i].o_ol[j].ol_quantity;
            ol_amount  = orders_buf[i].o_ol[j].ol_amount;

            strcpy(ol_delivery_d,orders_buf[i].o_ol[j].ol_delivery_d);
            strcpy(ol_dist_info,orders_buf[i].o_ol[j].ol_dist_info);

            rc = bcp_sendrow(o_hdbc3);
            if (rc != SUCCEED)
                HandleErrorDBC(o_hdbc3);

            order_line_rows_loaded++;
            CheckForCommit(o_hdbc3, o_hstmt3, order_line_rows_loaded,
"order_line", &order_line_time_start->time_start);
        }
    }

    // rcint = bcp_batch(o_hdbc3);
    // if (rcint < 0)
    //     HandleErrorDBC(o_hdbc3);

    if ((o_w_id == aptr->num_warehouses) && (o_d_id == 10))
    {
        rcint = bcp_done(o_hdbc3);
        if (rcint < 0)
            HandleErrorDBC(o_hdbc3);

        SQLFreeStmt(o_hstmt3, SQL_DROP);
        SQLDisconnect(o_hdbc3);
        SQLFreeConnect(o_hdbc3);

        // if build index after load...
        if ((aptr->build_index == 1) && (aptr->index_order == 0))
            BuildIndex("idxodlcl");
    }
}

//=====
//
// Function   : GetPermutation
//
//=====
void GetPermutation(int perm[], int n)
{
    int i, r, t;
```

## Appendix B - Database Design

```
for (i=1;i<=n;i++)
    perm[i] = i;

for (i=1;i<=n;i++)
{
    r = RandomNumber(i,n);
    t = perm[i];
    perm[i] = perm[r];
    perm[r] = t;
}

}

//=====
//
// Function   : CheckForCommit
//
//=====

void CheckForCommit(HDBC hdbc,
                   HSTMT hstmt,
                   int rows_loaded,
                   char *table_name,
                   long *time_start)
{
    long time_end, time_diff;
    // DBINT rcint;

    if ( !(rows_loaded % aptr->batch) )
    {
        // rcint = bcp_batch(hdbc);
        // if (rcint < 0)
        //     HandleErrorDBC(hdbc);

        time_end = (TimeNow() / MILLI);
        time_diff = time_end - *time_start;

        printf("-> Loaded %ld rows into %s in %ld sec - Total = %d (%.2f
rps)\n",
               aptr->batch,
               table_name,
               time_diff,
               rows_loaded,
               (float) aptr->batch / (time_diff ? time_diff :
1L));

        *time_start = time_end;
    }

    return;
}

//=====
//
// Function   : OpenConnections
//
//=====
```

```
void OpenConnections()
{
    RETCODE      rc;

    char          szDriverString[300];
    char          szDriverStringOut[1024];
    SQLSMALLINT  cbDriverStringOut;

    SQLAllocHandle(SQL_HANDLE_ENV, SQL_NULL_HANDLE, &henv );

    SQLSetEnvAttr(henv, SQL_ATTR_ODBC_VERSION, (void*)SQL_OV_ODBC3, 0 );

    SQLAllocHandle(SQL_HANDLE_DBC, henv , &i_hdbc1);
    SQLAllocHandle(SQL_HANDLE_DBC, henv , &w_hdbc1);
    SQLAllocHandle(SQL_HANDLE_DBC, henv , &c_hdbc1);
    SQLAllocHandle(SQL_HANDLE_DBC, henv , &c_hdbc2);
    SQLAllocHandle(SQL_HANDLE_DBC, henv , &o_hdbc1);
    SQLAllocHandle(SQL_HANDLE_DBC, henv , &o_hdbc2);
    SQLAllocHandle(SQL_HANDLE_DBC, henv , &o_hdbc3);

    SQLSetConnectAttr(i_hdbc1, SQL_COPT_SS_BCP, (void *)SQL_BCP_ON, SQL_IS_INTEGER
);
    SQLSetConnectAttr(w_hdbc1, SQL_COPT_SS_BCP, (void *)SQL_BCP_ON, SQL_IS_INTEGER
);
    SQLSetConnectAttr(c_hdbc1, SQL_COPT_SS_BCP, (void *)SQL_BCP_ON, SQL_IS_INTEGER
);
    SQLSetConnectAttr(c_hdbc2, SQL_COPT_SS_BCP, (void *)SQL_BCP_ON, SQL_IS_INTEGER
);
    SQLSetConnectAttr(o_hdbc1, SQL_COPT_SS_BCP, (void *)SQL_BCP_ON, SQL_IS_INTEGER
);
    SQLSetConnectAttr(o_hdbc2, SQL_COPT_SS_BCP, (void *)SQL_BCP_ON, SQL_IS_INTEGER
);
    SQLSetConnectAttr(o_hdbc3, SQL_COPT_SS_BCP, (void *)SQL_BCP_ON, SQL_IS_INTEGER
);

    // Open connections to SQL Server
    // Connection 1

    sprintf( szDriverString , "DRIVER={SQL
Server};SERVER=%s;UID=%s;PWD=%s;DATABASE=%s" ,
            aptr->server,
            aptr->user,
            aptr->password,
            aptr->database );

    rc = SQLSetConnectOption (i_hdbc1, SQL_PACKET_SIZE, aptr->pack_size);
    if (rc != SUCCEED)
        HandleErrorDBC(i_hdbc1);

    rc = SQLDriverConnect ( i_hdbc1,
                            NULL,
                            (SQLCHAR*)&szDriverString[0],
                            SQL_NTS,
                            (SQLCHAR*)&szDriverStringOut[0],
                            sizeof(szDriverStringOut),
                            &cbDriverStringOut,
                            SQL_DRIVER_NOPROMPT );

    if (rc != SUCCEED)
```

## Appendix B - Database Design

```
        HandleErrorDBC(i_hdbc1);
// Connection 2
    sprintf( szDriverString , "DRIVER={SQL
Server};SERVER=%s;UID=%s;PWD=%s;DATABASE=%s" ,
        aptr->server,
        aptr->user,
        aptr->password,
        aptr->database );

    rc = SQLSetConnectOption (w_hdbc1, SQL_PACKET_SIZE, aptr->pack_size);
    if (rc != SUCCEED)
        HandleErrorDBC(w_hdbc1);

    rc = SQLDriverConnect ( w_hdbc1,
        NULL,
        (SQLCHAR*)&szDriverString[0] ,
        SQL_NTS,
        (SQLCHAR*)&szDriverStringOut[0],
        sizeof(szDriverStringOut),
        &cbDriverStringOut,
        SQL_DRIVER_NOPROMPT
    );
    if (rc != SUCCEED)
        HandleErrorDBC(w_hdbc1);
// Connection 3
    sprintf( szDriverString , "DRIVER={SQL
Server};SERVER=%s;UID=%s;PWD=%s;DATABASE=%s" ,
        aptr->server,
        aptr->user,
        aptr->password,
        aptr->database );

    rc = SQLSetConnectOption (c_hdbc1, SQL_PACKET_SIZE, aptr->pack_size);
    if (rc != SUCCEED)
        HandleErrorDBC(c_hdbc1);

    rc = SQLDriverConnect ( c_hdbc1,
        NULL,
        (SQLCHAR*)&szDriverString[0] ,
        SQL_NTS,
        (SQLCHAR*)&szDriverStringOut[0],
        sizeof(szDriverStringOut),
        &cbDriverStringOut,
        SQL_DRIVER_NOPROMPT
    );
    if (rc != SUCCEED)
        HandleErrorDBC(c_hdbc1);
// Connection 4
    sprintf( szDriverString , "DRIVER={SQL
Server};SERVER=%s;UID=%s;PWD=%s;DATABASE=%s" ,
        aptr->server,
        aptr->user,
        aptr->password,
        aptr->database );

    rc = SQLSetConnectOption (c_hdbc2, SQL_PACKET_SIZE, aptr->pack_size);
    if (rc != SUCCEED)
        HandleErrorDBC(c_hdbc2);

    rc = SQLDriverConnect ( c_hdbc2,
        NULL,
        (SQLCHAR*)&szDriverString[0] ,
        SQL_NTS,
        (SQLCHAR*)&szDriverStringOut[0],
        sizeof(szDriverStringOut),
        &cbDriverStringOut,
        SQL_DRIVER_NOPROMPT
    );
    if (rc != SUCCEED)
        HandleErrorDBC(c_hdbc2);
// Connection 5
    sprintf( szDriverString , "DRIVER={SQL
Server};SERVER=%s;UID=%s;PWD=%s;DATABASE=%s" ,
        aptr->server,
        aptr->user,
        aptr->password,
        aptr->database );

    rc = SQLSetConnectOption (o_hdbc1, SQL_PACKET_SIZE, aptr->pack_size);
    if (rc != SUCCEED)
        HandleErrorDBC(o_hdbc1);

    rc = SQLDriverConnect ( o_hdbc1,
        NULL,
        (SQLCHAR*)&szDriverString[0] ,
        SQL_NTS,
        (SQLCHAR*)&szDriverStringOut[0],
        sizeof(szDriverStringOut),
        &cbDriverStringOut,
        SQL_DRIVER_NOPROMPT
    );
    if (rc != SUCCEED)
        HandleErrorDBC(o_hdbc1);
// Connection 6
    sprintf( szDriverString , "DRIVER={SQL
Server};SERVER=%s;UID=%s;PWD=%s;DATABASE=%s" ,
        aptr->server,
        aptr->user,
        aptr->password,
        aptr->database );

    rc = SQLSetConnectOption (o_hdbc2, SQL_PACKET_SIZE, aptr->pack_size);
    if (rc != SUCCEED)
        HandleErrorDBC(o_hdbc2);
```

## Appendix B - Database Design

```
rc = SQLDriverConnect ( o_hdbc2,
                        NULL,
                        (SQLCHAR*)&szDriverString[0] ,
                        SQL_NTS,
                        (SQLCHAR*)&szDriverStringOut[0],
                        sizeof(szDriverStringOut),
                        &cbDriverStringOut,
                        SQL_DRIVER_NOPROMPT
);
if (rc != SUCCEED)
    HandleErrorDBC(o_hdbc2);
// Connection 7
sprintf( szDriverString , "DRIVER={SQL
Server};SERVER=%s;UID=%s;PWD=%s;DATABASE=%s" ,
        aptr->server,
        aptr->user,
        aptr->password,
        aptr->database );
rc = SQLSetConnectOption (o_hdbc3, SQL_PACKET_SIZE, aptr->pack_size);
if (rc != SUCCEED)
    HandleErrorDBC(o_hdbc3);
rc = SQLDriverConnect ( o_hdbc3,
                        NULL,
                        (SQLCHAR*)&szDriverString[0] ,
                        SQL_NTS,
                        (SQLCHAR*)&szDriverStringOut[0],
                        sizeof(szDriverStringOut),
                        &cbDriverStringOut,
                        SQL_DRIVER_NOPROMPT
);
if (rc != SUCCEED)
    HandleErrorDBC(o_hdbc3);
}
//=====
//
// Function name: BuildIndex
//
//=====
void BuildIndex(char      *index_script)
{
    char      cmd[256];

    printf("Starting index creation:  %s\n",index_script);

    sprintf(cmd, "isql -S%s -U%s -P%s -e -i%s\\%s.sql > logs\\%s.log",
            aptr->server,
            aptr->user,
            aptr->password,
            aptr->index_script_path,
            index_script,
            index_script);

    system(cmd);

    printf("Finished index creation:  %s\n",index_script);
}

void HandleErrorDBC (SQLHDBC  hdbc1)
{
    SQLCHAR      SqlState[6], Msg[SQL_MAX_MESSAGE_LENGTH];
    SQLINTEGER   NativeError;
    SQLSMALLINT  i, MsgLen;
    SQLRETURN    rc2;
    char         timebuf[128];
    char         datebuf[128];
    FILE         *fp1;

    i = 1;
    while (( rc2 = SQLGetDiagRec(SQL_HANDLE_DBC , hdbc1, i, SqlState ,
    &NativeError,
                                Msg, sizeof(Msg) , &MsgLen )) != SQL_NO_DATA )
    {
        sprintf( szLastError , "%s" , Msg );
        _strtime(timebuf);
        _strdate(datebuf);

        printf( "[%s : %s] %s\n" , datebuf, timebuf, szLastError);

        fp1 = fopen("logs\\tpccldr.err","w");
        if (fp1 == NULL)
            printf("ERROR:  Unable to open errorlog file.\n");
        else
        {
            fprintf(fp1, "[%s : %s] %s\n" , datebuf, timebuf,
            szLastError);

            fclose(fp1);
        }

        i++;
    }
}

void FormatDate ( char* szTimeCOutput )
{
    struct tm when;
    time_t now;

    time( &now );
    when = *localtime( &now );

    mktime( &when );

    // odbc datetime format
    strftime( szTimeCOutput , 30 , "%Y-%m-%d %H:%M:%S.000", &when );
}
```

## Appendix B - Database Design

```
        return;
    }
}
```

### getargs.c

```
//      File:          GETARGS.C
//
//      Microsoft TPC-C Kit Ver. 4.00
//      Copyright Microsoft, 1996, 1997, 1998
//      Purpose: Source file for command line processing

// Includes
#include "tpcc.h"

//=====
//
// Function name: GetArgsLoader
//
//=====

void GetArgsLoader(int argc, char **argv, TPCC_LDR_ARGS *pargs)
{
    int    i;
    char *ptr;

#ifdef DEBUG
    printf("[%d]DBG: Entering GetArgsLoader()\n", (int) GetCurrentThreadId());
#endif

    /* init args struct with some useful values */
    pargs->server      = SERVER;
    pargs->user         = USER;
    pargs->password     = PASSWORD;
    pargs->database     = DATABASE;
    pargs->batch        = BATCH;
    pargs->num_warehouses = UNDEF;
    pargs->tables_all   = TRUE;
    pargs->table_item   = FALSE;
    pargs->table_warehouse = FALSE;
    pargs->table_customer = FALSE;
```

```
    pargs->table_orders      = FALSE;
    pargs->loader_res_file   = LOADER_RES_FILE;
    pargs->pack_size         = DEFLDPACKSIZE;
    pargs->starting_warehouse = DEF_STARTING_WAREHOUSE;
    pargs->build_index       = BUILD_INDEX;
    pargs->index_order       = INDEX_ORDER;
    pargs->index_script_path = INDEX_SCRIPT_PATH;
    pargs->scale_down        = SCALE_DOWN;

    /* check for zero command line args */
    if ( argc == 1 )
        GetArgsLoaderUsage();

    for ( i = 1; i < argc; ++i)
    {
        if (argv[i][0] != '-' && argv[i][0] != '/')
        {
            printf("\nUnrecognized command");
            GetArgsLoaderUsage();
            exit(1);
        }

        ptr = argv[i];

        switch (ptr[1])
        {
            case 'h': /* Fall throught */
            case 'H':
                GetArgsLoaderUsage();
                break;

            case 'D':
                pargs->database = ptr+2;
                break;

            case 'P':
                pargs->password = ptr+2;
                break;

            case 'S':
                pargs->server = ptr+2;
                break;

            case 'U':
                pargs->user = ptr+2;
                break;

            case 'b':
                pargs->batch = atol(ptr+2);
                break;

            case 'W':
                pargs->num_warehouses = atol(ptr+2);
                break;

            case 's':
                pargs->starting_warehouse = atol(ptr+2);
                break;

            case 't':
                {
                    pargs->tables_all = FALSE;
                    if (strcmp(ptr+2,"item") == 0)
```

## Appendix B - Database Design

```
0)
TRUE;

        pargs->table_item = TRUE;
    else if (strcmp(ptr+2,"warehouse") ==
        pargs->table_warehouse =
    else if (strcmp(ptr+2,"customer") == 0)
        pargs->table_customer = TRUE;
    else if (strcmp(ptr+2,"orders") == 0)
        pargs->table_orders = TRUE;
    else
    {
        printf("\nUnrecognized command");
        GetArgsLoaderUsage();
        exit(1);
    }
    break;

case 'f':
    pargs->loader_res_file = ptr+2;
    break;

case 'p':
    pargs->pack_size = atol(ptr+2);
    break;

case 'i':
    pargs->build_index = atol(ptr+2);
    break;

case 'o':
    pargs->index_order = atol(ptr+2);
    break;

case 'c':
    pargs->scale_down = atol(ptr+2);
    break;

case 'd':
    pargs->index_script_path = ptr+2;
    break;

default:
    GetArgsLoaderUsage();
    exit(-1);
    break;
}

/* check for required args */
if (pargs->num_warehouses == UNDEF )
{
    printf("Number of Warehouses is required\n");
    exit(-2);
}

return;
}

//=====
//
```

```
// Function name: GetArgsLoaderUsage
//
//=====
void GetArgsLoaderUsage()
{
#ifdef DEBUG
    printf("[%ld]DBG: Entering GetArgsLoaderUsage()\n", (int) GetCurrentThreadId());
#endif

    printf("TPCCCLR:\n\n");
    printf("Parameter                                     Default\n");
    printf("-----\n");
    printf("-W Number of Warehouses to Load                Required \n");
    printf("-S Server                                         %s\n, SERVER);
    printf("-U Username                                       %s\n, USER);
    printf("-P Password                                       %s\n, PASSWORD);
    printf("-D Database                                       %s\n, DATABASE);
    printf("-b Batch Size                                     %ld\n", (long)
BATCH);
    printf("-p TDS packet size                               %ld\n", (long)
DEFLDPACKSIZE);
    printf("-f Loader Results Output Filename             %s\n",
LOADER_RES_FILE);
    printf("-s Starting Warehouse                           %ld\n", (long)
DEF_STARTING_WAREHOUSE);
    printf("-i Build Option (data = 0, data and index = 1) %ld\n", (long)
BUILD_INDEX);
    printf("-o Cluster Index Build Order (before = 1, after = 0) %ld\n", (long)
INDEX_ORDER);
    printf("-c Build Scaled Database (normal = 0, tiny = 1) %ld\n", (long)
SCALE_DOWN);
    printf("-d Index Script Path                           %s\n",
INDEX_SCRIPT_PATH);
    printf("-t Table to Load                                 all tables \n");
    printf("    [item|warehouse|customer|orders]\n");
    printf("    Notes: \n");
    printf("    - the '-t' parameter may be included multiple times to \n");
    printf("    specify multiple tables to be loaded \n");
    printf("    - 'item' loads ITEM table \n");
    printf("    - 'warehouse' loads WAREHOUSE, DISTRICT, and STOCK tables \n");
    printf("    - 'customer' loads CUSTOMER and HISTORY tables \n");
    printf("    - 'orders' load NEW-ORDER, ORDERS, ORDER-LINE tables \n");

    printf("\nNote: Command line switches are case sensitive.\n");

    exit(0);
}

}

random.c

//      File:          RANDOM.C
//
//      Microsoft TPC-C Kit Ver. 4.00
//      Copyright Microsoft, 1996, 1997, 1998
```

## Appendix B - Database Design

```
// Purpose: Random number generation routines for database loader

// Includes
#include "tpcc.h"
#include "math.h"

// Defines
#define A 16807
#define M 2147483647
#define Q 127773 /* M div A */
#define R 2836 /* M mod A */
#define Thread __declspec(thread)

// Globals
long Thread Seed = 0; /* thread local seed */

/*****
 * random -
 * Implements a GOOD pseudo random number generator. This generator
 * will/should? run the complete period before repeating.
 *
 * Copied from:
 * Random Numbers Generators: Good Ones Are Hard to Find.
 * Communications of the ACM - October 1988 Volume 31 Number 10
 *
 * Machine Dependencies:
 * long must be 2 ^ 31 - 1 or greater.
 *****/

/*****
 * seed - load the Seed value used in irand and drand. Should be used before
 * first call to irand or drand.
 *****/

void seed(long val)
{
#ifdef DEBUG
    printf("[%ld]DBG: Entering seed()...\n", (int) GetCurrentThreadId());
    printf("Old Seed %ld New Seed %ld\n",Seed, val);
#endif

    if ( val < 0 )
        val = abs(val);

    Seed = val;
}

/*****
 *
 * irand - returns a 32 bit integer pseudo random number with a period of
 * 1 to 2 ^ 32 - 1.
 *
 * parameters:
 * none.
 *
 * returns:
 * 32 bit integer - defined as long ( see above ).
 *****/
```

```
*
* side effects:
* seed get recomputed.
*****/

long irand()
{
    register long s; /* copy of seed */
    register long test; /* test flag */
    register long hi; /* tmp value for speed */
    register long lo; /* tmp value for speed */

#ifdef DEBUG
    printf("[%ld]DBG: Entering irand()...\n", (int) GetCurrentThreadId());
#endif

    s = Seed;
    hi = s / Q;
    lo = s % Q;

    test = A * lo - R * hi;
    if ( test > 0 )
        Seed = test;
    else
        Seed = test + M;

    return( Seed );
}

/*****
 *
 * drand - returns a double pseudo random number between 0.0 and 1.0.
 * See irand.
 *****/

double drand()
{
#ifdef DEBUG
    printf("[%ld]DBG: Entering drand()...\n", (int) GetCurrentThreadId());
#endif

    return( (double)irand() / 2147483647.0 );
}

//=====
// Function : RandomNumber
//
// Description:
//=====
long RandomNumber(long lower, long upper)
{
    long rand_num;

#ifdef DEBUG
    printf("[%ld]DBG: Entering RandomNumber()...\n", (int) GetCurrentThreadId());
#endif

    if ( upper == lower ) /* pgd 08-13-96 perf enhancement */
        return lower;

    upper++;
```

## Appendix B - Database Design

---

```
    if ( upper <= lower )
        rand_num = upper;
    else
        rand_num = lower + irand() % (upper - lower); /* pgd 08-13-96 perf
enhancement */

#ifdef DEBUG
    printf("[%ld]DBG: RandomNumber between %ld & %ld ==> %ld\n",
           (int) GetCurrentThreadId(), lower, upper,
           rand_num);
#endif

    return rand_num;
}

#if 0
//Original code pgd 08/13/96
long RandomNumber(long lower,
                  long upper)
{
    long rand_num;

#ifdef DEBUG
    printf("[%ld]DBG: Entering RandomNumber()...\n", (int) GetCurrentThreadId());
#endif

    upper++;

    if ((upper <= lower))
        rand_num = upper;
    else
        rand_num = lower + irand() % ((upper > lower) ? upper - lower :
upper);

#ifdef DEBUG
    printf("[%ld]DBG: RandomNumber between %ld & %ld ==> %ld\n",
           (int) GetCurrentThreadId(), lower, upper,
           rand_num);
#endif

    return rand_num;
}
#endif

//=====
// Function : NURand
//
// Description:
//=====
long NURand(int iConst,
            long x,
            long y,
            long C)
{
    long rand_num;
```

```
#ifdef DEBUG
    printf("[%ld]DBG: Entering NURand()...\n", (int) GetCurrentThreadId());
#endif

    rand_num = (((RandomNumber(0,iConst) | RandomNumber(x,y)) + C) % (y-x+1))+x;

#ifdef DEBUG
    printf("[%ld]DBG: NURand: num = %d\n", (int) GetCurrentThreadId(), rand_num);
#endif

    return rand_num;
}
```

### strings.c

```
// File: STRINGS.C
// Microsoft TPC-C Kit Ver. 4.00
// Copyright Microsoft, 1996, 1997, 1998
// Purpose: Source file for database loader string functions

// Includes
#include "tpcc.h"
#include <string.h>
#include <ctype.h>

//=====
//
// Function name: MakeAddress
//
//=====

void MakeAddress(char *street_1,
                 char *street_2,
                 char *city,
                 char *state,
                 char *zip)
{
#ifdef DEBUG
    printf("[%ld]DBG: Entering MakeAddress()\n", (int) GetCurrentThreadId());
#endif

    MakeAlphaString (10, 20, ADDRESS_LEN, street_1);
    MakeAlphaString (10, 20, ADDRESS_LEN, street_2);
    MakeAlphaString (10, 20, ADDRESS_LEN, city);
    MakeAlphaString ( 2,  2, STATE_LEN, state);
    MakeZipNumberString( 9,  9, ZIP_LEN, zip);

#ifdef DEBUG
    printf("[%ld]DBG: MakeAddress: street_1: %s, street_2: %s, city: %s, state: %s, zip:
%s\n",
           (int) GetCurrentThreadId(), street_1, street_2, city,
           state, zip);
#endif
}
```

## Appendix B - Database Design

```
return;
}

//=====
//
// Function name: LastName
//
//=====
void LastName(int num,
             char *name)
{
    static char *n[] =
    {
        "BAR" , "OUGHT" , "ABLE" , "PRI" , "PRES",
        "ESE" , "ANTI" , "CALLY" , "ATION" , "EING"
    };

#ifdef DEBUG
    printf("[%ld]DBG: Entering LastName()\n", (int) GetCurrentThreadId());
#endif

    if ((num >= 0) && (num < 1000))
    {
        strcpy(name, n[(num/100)%10]);
        strcat(name, n[(num/10)%10]);
        strcat(name, n[(num/1)%10]);

        if (strlen(name) < LAST_NAME_LEN)
        {
            PaddString(LAST_NAME_LEN, name);
        }
    }
    else
    {
        printf("\nError in LastName()... num < %ld> out of range (0,999)\n",
            num);
        exit(-1);
    }

#ifdef DEBUG
    printf("[%ld]DBG: LastName: num = [%d] ==> [%d][%d][%d]\n",
        (int) GetCurrentThreadId(), num, num/100, (num/10)%10,
        num%10);
    printf("[%ld]DBG: LastName: String = %s\n", (int) GetCurrentThreadId(), name);
#endif

    return;
}

//=====
//
// Function name: MakeAlphaString
//
//=====
```

```
//philipdu 08/13/96 Changed MakeAlphaString to use A-Z, a-z, and 0-9 in
//accordance with spec see below:
//The spec says:
//4.3.2.2 The notation random a-string [x .. y]
//(respectively, n-string [x .. y]) represents a string of random alphanumeric
//(respectively, numeric) characters of a random length of minimum x, maximum y,
//and mean (y+x)/2. Alphanumerics are A..Z, a..z, and 0..9. The only other
//requirement is that the character set used "must be able to represent a minimum
//of 128 different characters". We are using 8-bit chars, so this is a non issue.
//It is completely unreasonable to stuff non-printing chars into the text fields.
//-CLevine 08/13/96

int MakeAlphaString( int x, int y, int z, char *str)
{
    int len;
    int i;
    static char chArray[] =
    "0123456789ABCDEFGHIJKLMNOPQRSTUVWXYZabcdefghijklmnopqrstuvwxyz";
    static int chArrayMax = 61;

#ifdef DEBUG
    printf("[%ld]DBG: Entering MakeAlphaString()\n", (int) GetCurrentThreadId());
#endif

    len= RandomNumber(x, y);

    for (i=0; i<len; i++)
        str[i] = chArray[RandomNumber(0, chArrayMax)];
    if ( len < z )
        memset(str+len, ' ', z - len);
    str[len] = 0;

    return len;
}

//=====
//
// Function name: MakeOriginalAlphaString
//
//=====
int MakeOriginalAlphaString(int x,
                           int y,
                           int z,
                           char *str,
                           int percent)
{
    int len;
    int val;
    int start;

#ifdef DEBUG
    printf("[%ld]DBG: Entering MakeOriginalAlphaString()\n", (int) GetCurrentThreadId());
#endif

    // verify percentage is valid
    if ((percent < 0) || (percent > 100))
    {
        printf("MakeOrigianlAlphaString: Invalid percentage: %d\n", percent);
        exit(-1);
    }
}
```

## Appendix B - Database Design

```
// verify string is at least 8 chars in length
if ((x + y) <= 8)
{
    printf("MakeOriginalAlphaString: string length must be >= 8\n");
    exit(-1);
}

// Make Alpha String
len = MakeAlphaString(x,y, z, str);

val = RandomNumber(1,100);
if (val <= percent)
{
    start = RandomNumber(0, len - 8);
    strncpy(str + start, "ORIGINAL", 8);
}

#ifdef DEBUG
printf("[%ld]DBG: MakeOriginalAlphaString: : %s\n",
      (int) GetCurrentThreadId(), str);
#endif

return strlen(str);
}

//=====
//
// Function name: MakeNumberString
//
//=====
int MakeNumberString(int x, int y, int z, char *str)
{
    char tmp[16];

    //MakeNumberString is always called MakeZipNumberString(16, 16, 16, string)

    memset(str, '0', 16);
    itoa(RandomNumber(0, 99999999), tmp, 10);
    memcpy(str, tmp, strlen(tmp));

    itoa(RandomNumber(0, 99999999), tmp, 10);
    memcpy(str+8, tmp, strlen(tmp));

    str[16] = 0;

return 16;
}

//=====
//
// Function name: MakeZipNumberString
//
//=====
int MakeZipNumberString(int x, int y, int z, char *str)
{
    char tmp[16];

    //MakeZipNumberString is always called MakeZipNumberString(9, 9, 9, string)

    strcpy(str, "000011111");
```

```
    itoa(RandomNumber(0, 9999), tmp, 10);
    memcpy(str, tmp, strlen(tmp));

return 9;
}

//=====
//
// Function name: InitString
//
//=====
void InitString(char *str, int len)
{
#ifdef DEBUG
printf("[%ld]DBG: Entering InitString()\n", (int) GetCurrentThreadId());
#endif

    memset(str, ' ', len);
    str[len] = 0;
}

//=====
// Function name: InitAddress
//
// Description:
//
//=====
void InitAddress(char *street_1, char *street_2, char *city, char *state, char *zip)
{
    memset(street_1, ' ', ADDRESS_LEN+1);
    memset(street_2, ' ', ADDRESS_LEN+1);
    memset(city, ' ', ADDRESS_LEN+1);

    street_1[ADDRESS_LEN+1] = 0;
    street_2[ADDRESS_LEN+1] = 0;
    city[ADDRESS_LEN+1] = 0;

    memset(state, ' ', STATE_LEN+1);
    state[STATE_LEN+1] = 0;

    memset(zip, ' ', ZIP_LEN+1);
    zip[ZIP_LEN+1] = 0;
}

//=====
//
// Function name: PaddString
//
//=====
void PaddString(int max, char *name)
{
    int len;

    len = strlen(name);
    if ( len < max )
        memset(name+len, ' ', max - len);
    name[max] = 0;
}
```

## Appendix B - Database Design

---

```
        return;  
    }
```

### time.c

```
//      File:          TIME.C  
//      Microsoft TPC-C Kit Ver. 4.00  
//      Copyright Microsoft, 1996, 1997, 1998  
//      Purpose: Source file for time functions  
  
// Includes  
#include "tpcc.h"  
  
// Globals  
static long start_sec;  
  
//=====  
//  
// Function name: TimeNow  
//  
//=====  
  
long TimeNow()  
{  
    long        time_now;  
    struct _timeb el_time;  
  
#ifdef DEBUG  
    printf("[%ld]DBG: Entering TimeNow()\n", (int) GetCurrentThreadId());  
#endif  
  
    _ftime(&el_time);  
  
    time_now = ((el_time.time - start_sec) * 1000) + el_time.millitm;  
  
    return time_now;  
}
```

# Appendix C – Tunable Parameters

---

## Appendix C - Tunable Parameters

### *Server Configuration Parameters*

#### Microsoft Windows 2000 Advanced Server Parameters

The following registry key was added to disable the kernel counters for Global and Per-Process I/Os:

```
[HKEY_LOCAL_MACHINE\SYSTEM\CurrentControlSet\Control\Session Manager\I/O System]
"CountOperations"=dword:00000000
```

#### Microsoft Windows 2000 Advanced Server Configuration

The following services were disabled on the server:

- Alerter
- Computer Browser
- DHCP Client
- Distributed File System
- Distributed Link Tracking Client
- DNS Client
- Global Array Manager Server
- IPSEC Policy Agent
- License Logging Service
- Messenger
- Microsoft Search
- Print Spooler
- Process Control Service
- Remote Registry Service
- Removable Storage
- Run as Service
- System Event Notification
- Task Scheduler

#### Microsoft SQL Server 2000 Startup Parameters

Microsoft SQL Server was started with the following command line options

**sqlservr -c -x -T3502 -g100**

where

-c	Start SQL Server independently of the Microsoft Windows NT Service Control Manager.
-x	Disable the keeping of CPU time and cache-hit ratio statistics.
-T3502	Prints a message to the log at the beginning and end of each checkpoint.
-g100	Reserve 100 MB for non-buffer pool allocations

## Appendix C – Tunable Parameters

---

### Microsoft SQL Server Stack Size

The default stack size of Microsoft SQL Server was changed using the EDITBIN utility. The EDITBIN utility ships with Microsoft Visual C++ V5.0. The command used was editbin /stack:131072 sqlservr.exe.

### Mylex Device Drivers and Firmware

The following device drivers were added:

- Mylex BIOS: 6:00-05
- Mylex Firmware: 6.00-02 bld 127
- Miniport driver : 6.00-03 (dac2w2k.sys)
- Accelerated Driver : 5.50-20 (macdw2k.sys)

### Mylex Registry Key

```
[HKEY_LOCAL_MACHINE\SYSTEM\CurrentControlSet\Services\dac2w2k\Parameters\Device]
"DriverParameter"="ConfigureSIR=16"
```

### Microsoft SQL Server 2000 Configuration Parameters

name	minimum	maximum	config_value	run_value
affinity mask	0	2147483647	15	15
allow updates	0	1	1	1
c2 audit mode	0	1	0	0
cost threshold for parallelism	0	32767	5	5
cursor threshold	-1	2147483647	-1	-1
default full-text language	0	2147483647	1033	1033
default language	0	9999	0	0
fill factor (%)	0	100	0	0
index create memory (KB)	704	1600000	0	0
language in cache	3	100	3	3
lightweight pooling	0	1	1	1
locks	5000	2147483647	0	0
max degree of parallelism	0	32	1	1
max server memory (MB)	4	2147483647	7000	7000
max text repl size (B)	0	2147483647	65536	65536
max worker threads	10	1024	220	220
media retention	0	365	0	0
min memory per query (KB)	512	2147483647	1024	1024
min server memory (MB)	0	2147483647	100	100
nested triggers	0	1	1	1
network packet size (B)	512	65535	4096	4096
open objects	0	2147483647	0	0
priority boost	0	1	1	1
query governor cost limit	0	2147483647	0	0
query wait (s)	-1	2147483647	-1	-1
recovery interval (min)	0	32767	40	40
remote access	0	1	0	0
remote login timeout (s)	0	2147483647	5	5
remote proc trans	0	1	0	0
remote query timeout (s)	0	2147483647	0	0
scan for startup procs	0	1	0	0
set working set size	0	1	0	0
show advanced options	0	1	1	1
two digit year cutoff	1753	9999	2049	2049
user connections	0	32767	0	0
user options	0	16383	0	0

## Appendix C – Tunable Parameters

---

### Windows 2000 Advanced Server System Information Report For PE6400

System Information report written at: 10/15/2000 05:02:39 PM  
[System Information]

[ Following are sub-categories of this main category ]

[System Summary]

Item Value

OS Name Microsoft Windows 2000 Advanced Server  
Version 5.0.2195 Service Pack 1 Build 2195  
OS Manufacturer Microsoft Corporation  
System Name PE6400\_01  
System Manufacturer Dell Computer Corporation  
System Model PowerEdge 6400/700  
System Type X86-based PC  
Processor x86 Family 6 Model 10 Stepping 0 GenuineIntel ~700 Mhz  
Processor x86 Family 6 Model 10 Stepping 0 GenuineIntel ~700 Mhz  
Processor x86 Family 6 Model 10 Stepping 0 GenuineIntel ~700 Mhz  
Processor x86 Family 6 Model 10 Stepping 0 GenuineIntel ~700 Mhz  
BIOS Version Phoenix ROM BIOS PLUS Version 1.10 X27  
Windows Directory C:\WINNT  
System Directory C:\WINNT\System32  
Boot Device \Device\Harddisk0\Partition1  
Locale United States  
User Name PE6400\_01\Administrator  
Time Zone Central Daylight Time  
Total Physical Memory 7,318,888 KB  
Available Physical Memory 7,145,812 KB  
Total Virtual Memory 16,597,708 KB  
Available Virtual Memory 16,366,996 KB  
Page File Space 9,278,820 KB  
Page File C:\pagefile.sys

[Hardware Resources]

[ Following are sub-categories of this main category ]

[Conflicts/Sharing]

Resource Device  
No conflicted/shared resources

[DMA]

Channel	Device	Status
4	Direct memory access controller	OK
2	Standard floppy disk controller	OK

[Forced Hardware]

## Appendix C – Tunable Parameters

---

Device PNP Device ID  
No Forced Hardware

[I/O]

Address Range	Device	Status
0x0000-0x03AF	PCI bus	OK
0x0000-0x03AF	Direct memory access controller	OK
0x03B0-0x03DF	PCI bus	OK
0x03B0-0x03DF	ATI Technologies Inc. 3D RAGE IIC PCI	OK
0x03E0-0x0FFF	PCI bus	OK
0xE000-0xFFFF	PCI bus	OK
0xFC00-0xFCFF	ATI Technologies Inc. 3D RAGE IIC PCI	OK
0x03C0-0x03DF	ATI Technologies Inc. 3D RAGE IIC PCI	OK
0xF800-0xF8FF	Adaptec AIC-7899 Ultra160/m PCI SCSI Card	OK
0xF400-0xF4FF	Adaptec AIC-7899 Ultra160/m PCI SCSI Card	OK
0xF0E0-0xF0FF	Intel(R) PRO/100+ PCI Adapter	OK
0x0A79-0x0A79	ISAPNP Read Data Port	OK
0x0279-0x0279	ISAPNP Read Data Port	OK
0x02F4-0x02F7	ISAPNP Read Data Port	OK
0x0080-0x009F	Direct memory access controller	OK
0x00C0-0x00DF	Direct memory access controller	OK
0x00F0-0x00FF	Numeric data processor	OK
0x0020-0x003F	Programmable interrupt controller	OK
0x00A0-0x00BF	Programmable interrupt controller	OK
0x04D0-0x04D1	Programmable interrupt controller	OK
0x0061-0x0061	System speaker	OK
0x0040-0x005F	System timer	OK
0x03F0-0x03F5	Standard floppy disk controller	OK
0x03F7-0x03F7	Standard floppy disk controller	OK
0x0060-0x0060	Standard 101/102-Key or Microsoft Natural PS/2	
Keyboard	OK	
0x0064-0x0064	Standard 101/102-Key or Microsoft Natural PS/2	
Keyboard	OK	
0x03F8-0x03FF	Communications Port (COM1)	OK
0x02F8-0x02FF	Communications Port (COM2)	OK
0x0378-0x037F	ECP Printer Port (LPT1)	OK
0x0778-0x077F	ECP Printer Port (LPT1)	OK
0x0070-0x007F	System CMOS/real time clock	OK
0x0814-0x085B	System board	OK
0x08A0-0x08AF	System board	OK
0x0C00-0x0CD7	System board	OK
0x0F50-0x0F58	System board	OK
0x00E0-0x00EF	System board	OK
0x8000-0xDFFF	PCI bus	OK
0xD000-0xDFFF	DEC 21154 PCI to PCI bridge	OK
0xDC80-0xDCFF	Mylex eXtremeRAID 2000 Disk Array Controller	OK
0xC000-0xCFFF	DEC 21154 PCI to PCI bridge	OK
0xCC80-0xCCFF	Mylex eXtremeRAID 2000 Disk Array Controller	OK
0xB000-0xBFFF	DEC 21154 PCI to PCI bridge	OK
0xBC80-0xBCFF	Mylex eXtremeRAID 2000 Disk Array Controller	OK
0xA000-0xAFFF	DEC 21154 PCI to PCI bridge	OK
0xAC80-0xACFF	Mylex eXtremeRAID 2000 Disk Array Controller	OK
0x6000-0x7FFF	PCI bus	OK

## Appendix C – Tunable Parameters

---

### [IRQs]

IRQ Number	Device
9	Microsoft ACPI-Compliant System
17	Adaptec AIC-7899 Ultra160/m PCI SCSI Card
18	Adaptec AIC-7899 Ultra160/m PCI SCSI Card
21	Intel(R) PRO/100+ PCI Adapter
13	Numeric data processor
6	Standard floppy disk controller
1	Standard 101/102-Key or Microsoft Natural PS/2 Keyboard
12	PS/2 Compatible Mouse
4	Communications Port (COM1)
3	Communications Port (COM2)
8	System CMOS/real time clock
15	System board
22	Mylex eXtremeRAID 2000 Disk Array Controller
23	Mylex eXtremeRAID 2000 Disk Array Controller
24	Mylex eXtremeRAID 2000 Disk Array Controller
25	Mylex eXtremeRAID 2000 Disk Array Controller

### [Memory]

Range	Device	Status
0xA0000-0xBFFFF	PCI bus	OK
0xA0000-0xBFFFF	ATI Technologies Inc. 3D RAGE IIC PCI	OK
0xDC000-0xEFFFF	PCI bus	OK
0xFAD00000-0xFBFFFFFFF	PCI bus	OK
0xFC000000-0xFD4FFFFFFF	PCI bus	OK
0xFC000000-0xFD4FFFFFFF	ATI Technologies Inc. 3D RAGE IIC PCI	OK
0xFE000000-0xFFFFFFFF	PCI bus	OK
0xFBEFF000-0xFBEFFFFFFF	ATI Technologies Inc. 3D RAGE IIC PCI	OK
0xFBEFE000-0xFBEFFFFFFF	Adaptec AIC-7899 Ultra160/m PCI SCSI Card	OK
0xFBEFD000-0xFBEFDFFF	Adaptec AIC-7899 Ultra160/m PCI SCSI Card	OK
0xFD4FF000-0xFD4FFFFFFF	Intel(R) PRO/100+ PCI Adapter	OK
0xFBD00000-0xFBDFFFFFFF	Intel(R) PRO/100+ PCI Adapter	OK
0x0000-0x9FFFF	System board	OK
0x100000-0xBFFFFFFF	System board	OK
0xF0000-0xFFFFF	System board	OK
0xFEC00000-0xFEC0FFFFF	System board	OK
0xFEE00000-0xFEE0FFFFF	System board	OK
0xFFE00000-0xFFFFFFFF	System board	OK
0xDE000000-0xEFFFFFFF	PCI bus	OK
0xF0000000-0xF9FFFFFFF	PCI bus	OK
0xF0000000-0xF9FFFFFFF	DEC 21154 PCI to PCI bridge	OK
0xF0000000-0xF9FFFFFFF	Mylex eXtremeRAID 2000 Disk Array Controller	OK
0xEC000000-0xEFFFFFFF	DEC 21154 PCI to PCI bridge	OK
0xEC000000-0xEFFFFFFF	Mylex eXtremeRAID 2000 Disk Array Controller	OK
0xF4000000-0xF7FFFFFFF	DEC 21154 PCI to PCI bridge	OK
0xF6000000-0xF7FFFFFFF	Mylex eXtremeRAID 2000 Disk Array Controller	OK
0xE8000000-0xEBFFFFFFF	DEC 21154 PCI to PCI bridge	OK

## Appendix C – Tunable Parameters

---

```

0xE8000000-0xEBFFFFFF Mylex eXtremeRAID 2000 Disk Array Controller
      OK
0xF8000000-0xF9FFFFFF DEC 21154 PCI to PCI bridge      OK
0xF8000000-0xF9FFFFFF Mylex eXtremeRAID 2000 Disk Array Controller
      OK
0xE4000000-0xE7FFFFFF DEC 21154 PCI to PCI bridge      OK
0xE4000000-0xE7FFFFFF Mylex eXtremeRAID 2000 Disk Array Controller
      OK
0xF2000000-0xF3FFFFFF DEC 21154 PCI to PCI bridge      OK
0xF2000000-0xF3FFFFFF Mylex eXtremeRAID 2000 Disk Array Controller
      OK
0xE0000000-0xE3FFFFFF DEC 21154 PCI to PCI bridge      OK
0xE0000000-0xE3FFFFFF Mylex eXtremeRAID 2000 Disk Array Controller
      OK
0xDC000000-0xDDFFFFFF PCI bus      OK
0xFDC00000-0xFDFFFFFF PCI bus      OK

```

[Components]

[ Following are sub-categories of this main category ]

[Multimedia]

[ Following are sub-categories of this main category ]

[Audio Codecs]

Codec	Manufacturer	Description	Status	File	Version	Size
c:\winnt\system32\iac25_32.ax	Intel Corporation	Indeo® audio software	OK	C:\WINNT\System32\IAC25_32.AX	2.05.53	195.00 KB (199,680 bytes)
c:\winnt\system32\imaadp32.acm	Microsoft Corporation		OK	C:\WINNT\System32\IMAADP32.ACM	5.00.2134.1	16.27 KB (16,656 bytes)
c:\winnt\system32\msg723.acm	Microsoft Corporation		OK	C:\WINNT\System32\MSG723.ACM	4.4.3385	106.77 KB (109,328 bytes)
c:\winnt\system32\msgsm32.acm	Microsoft Corporation		OK	C:\WINNT\System32\MSGSM32.ACM	5.00.2134.1	22.27 KB (22,800 bytes)
c:\winnt\system32\tssoft32.acm	DSP GROUP, INC.		OK	C:\WINNT\System32\TSSOFT32.ACM	1.01	9.27 KB (9,488 bytes)
c:\winnt\system32\lhacm.acm	Microsoft Corporation		OK	C:\WINNT\System32\LHACM.ACM	4.4.3385	33.27 KB (34,064 bytes)
c:\winnt\system32\msg711.acm	Microsoft Corporation		OK	C:\WINNT\System32\MSG711.ACM	5.00.2134.1	10.27 KB (10,512 bytes)
c:\winnt\system32\msadp32.acm	Microsoft Corporation		OK	C:\WINNT\System32\MSADP32.ACM	5.00.2134.1	14.77 KB (15,120 bytes)

[Video Codecs]

## Appendix C – Tunable Parameters

---

Codec	Manufacturer	Description	Status	File	Version	Size
c:\winnt\system32\ir50_32.dll	Intel Corporation	Indeo® video	5.10	OK		
	C:\WINNT\System32\IR50_32.DLL	R.5.10.15.2.55			737.50	KB
(755,200 bytes)		12/7/1999 6:00:00 AM				
c:\winnt\system32\msh261.drv	Microsoft Corporation			OK		
	C:\WINNT\System32\MSH261.DRV	4.4.3385			163.77	KB (167,696 bytes)
		9/13/2000 11:18:04 AM				
c:\winnt\system32\msh263.drv	Microsoft Corporation			OK		
	C:\WINNT\System32\MSH263.DRV	4.4.3385			252.27	KB (258,320 bytes)
		9/13/2000 11:17:41 AM				
c:\winnt\system32\msvidc32.dll	Microsoft Corporation			OK		
	C:\WINNT\System32\MSVIDC32.DLL	5.00.2134.1			27.27	KB (27,920 bytes)
		12/7/1999 6:00:00 AM				
c:\winnt\system32\ir32_32.dll	Intel(R) Corporation			OK		
	C:\WINNT\System32\IR32_32.DLL	Not Available			194.50	KB
(199,168 bytes)		12/7/1999 6:00:00 AM				
c:\winnt\system32\iccvid.dll	Radius Inc.			OK		
	C:\WINNT\System32\ICCVID.DLL	1.10.0.6			108.00	KB (110,592 bytes)
		12/7/1999 6:00:00 AM				
c:\winnt\system32\msrle32.dll	Microsoft Corporation			OK		
	C:\WINNT\System32\MSRLE32.DLL	5.00.2134.1			10.77	KB (11,024 bytes)
		12/7/1999 6:00:00 AM				

### [CD-ROM]

Item Value  
No CD-ROM drives

### [Sound Device]

Item Value  
No sound devices

### [Display]

Item Value  
Name ATI Technologies Inc. 3D RAGE IIC PCI  
PNP Device ID  
PCI\VEN\_1002&DEV\_4759&SUBSYS\_00000000&REV\_7A\3&13C0B0C5&0&20  
Adapter Type ATI 3D RAGE IIC PCI (A21), ATI Technologies Inc. compatible  
Adapter Description ATI Technologies Inc. 3D RAGE IIC PCI  
Adapter RAM 4.00 MB (4,194,304 bytes)  
Installed Drivers atiraged.dll  
Driver Version 5.00.2174.1  
INF File display.inf (atirage section)  
Color Planes 1  
Color Table Entries 256  
Resolution 1024 x 768 x 60 hertz  
Bits/Pixel 8

### [Infrared]

## Appendix C – Tunable Parameters

---

Item Value  
No infrared devices

[Input]

[ Following are sub-categories of this main category ]

[Keyboard]

Item Value  
Description Standard 101/102-Key or Microsoft Natural PS/2 Keyboard  
Name Enhanced (101- or 102-key)  
Layout 00000409  
PNP Device ID ACPI\PNP0303\4&3B8C0623&0  
NumberOfFunctionKeys 12

[Pointing Device]

Item Value  
Hardware Type PS/2 Compatible Mouse  
Number of Buttons 2  
Status OK  
PNP Device ID ACPI\PNP0F13\4&3B8C0623&0  
Power Management Supported False  
Double Click Threshold 6  
Handedness Right Handed Operation

[Modem]

Item Value  
No modems

[Network]

[ Following are sub-categories of this main category ]

[Adapter]

Item Value  
Name [00000000] RAS Async Adapter  
Adapter Type Not Available  
Product Name RAS Async Adapter  
Installed True  
PNP Device ID Not Available  
Last Reset 10/12/2000 6:49:26 AM  
Index 0  
Service Name AsyncMac  
IP Address Not Available  
IP Subnet Not Available  
Default IP Gateway Not Available  
DHCP Enabled False  
DHCP Server Not Available

## Appendix C – Tunable Parameters

---

DHCP Lease Expires Not Available  
DHCP Lease Obtained Not Available  
MAC Address Not Available  
Service Name Not Available

Name [00000001] WAN Miniport (L2TP)  
Adapter Type Not Available  
Product Name WAN Miniport (L2TP)  
Installed True  
PNP Device ID ROOT\MS\_L2TPMINIPOINT\0000  
Last Reset 10/12/2000 6:49:26 AM  
Index 1  
Service Name Rasl2tp  
IP Address Not Available  
IP Subnet Not Available  
Default IP Gateway Not Available  
DHCP Enabled False  
DHCP Server Not Available  
DHCP Lease Expires Not Available  
DHCP Lease Obtained Not Available  
MAC Address Not Available  
Service Name Rasl2tp  
Driver c:\winnt\system32\drivers\rasl2tp.sys (50800, 5.00.2179.1)

Name [00000002] WAN Miniport (PPTP)  
Adapter Type Wide Area Network (WAN)  
Product Name WAN Miniport (PPTP)  
Installed True  
PNP Device ID ROOT\MS\_PPTPMINIPOINT\0000  
Last Reset 10/12/2000 6:49:26 AM  
Index 2  
Service Name PptpMiniport  
IP Address Not Available  
IP Subnet Not Available  
Default IP Gateway Not Available  
DHCP Enabled False  
DHCP Server Not Available  
DHCP Lease Expires Not Available  
DHCP Lease Obtained Not Available  
MAC Address 50:50:54:50:30:30  
Service Name PptpMiniport  
Driver c:\winnt\system32\drivers\raspptp.sys (47856, 5.00.2160.1)

Name [00000003] Direct Parallel  
Adapter Type Not Available  
Product Name Direct Parallel  
Installed True  
PNP Device ID ROOT\MS\_PTIMINIPOINT\0000  
Last Reset 10/12/2000 6:49:26 AM  
Index 3  
Service Name Raspti  
IP Address Not Available  
IP Subnet Not Available  
Default IP Gateway Not Available  
DHCP Enabled False

## Appendix C – Tunable Parameters

---

DHCP Server Not Available  
DHCP Lease Expires Not Available  
DHCP Lease Obtained Not Available  
MAC Address Not Available  
Service Name Raspti  
Driver c:\winnt\system32\drivers\raspti.sys (16880, 5.00.2146.1)

Name [00000004] WAN Miniport (IP)  
Adapter Type Not Available  
Product Name WAN Miniport (IP)  
Installed True  
PNP Device ID ROOT\MS\_NDISWANIP\0000  
Last Reset 10/12/2000 6:49:26 AM  
Index 4  
Service Name NdisWan  
IP Address Not Available  
IP Subnet Not Available  
Default IP Gateway Not Available  
DHCP Enabled False  
DHCP Server Not Available  
DHCP Lease Expires Not Available  
DHCP Lease Obtained Not Available  
MAC Address Not Available  
Service Name NdisWan  
Driver c:\winnt\system32\drivers\ndiswan.sys (90768, 5.00.2184.1)

Name [00000005] Intel(R) PRO/100+ PCI Adapter  
Adapter Type Ethernet 802.3  
Product Name Intel(R) PRO/100+ PCI Adapter  
Installed True  
PNP Device ID  
PCI\VEN\_8086&DEV\_1229&SUBSYS\_00098086&REV\_05\3&13C0B0C5&0&38  
Last Reset 10/12/2000 6:49:26 AM  
Index 5  
Service Name E100B  
IP Address 192.1.1.100  
IP Subnet 255.255.255.0  
Default IP Gateway Not Available  
DHCP Enabled False  
DHCP Server Not Available  
DHCP Lease Expires Not Available  
DHCP Lease Obtained Not Available  
MAC Address 00:90:27:5C:D1:CC  
Service Name E100B  
IRQ Number 21  
I/O Port 0xF0E0-0xF0FF  
Driver c:\winnt\system32\drivers\e100bnt5.sys (85776,  
4.02.38.0000)

[Protocol]

Item Value  
Name MSAFD Tcpi [TCP/IP]  
ConnectionlessService False

## Appendix C – Tunable Parameters

---

GuaranteesDelivery True  
GuaranteesSequencing True  
MaximumAddressSize 16 bytes  
MaximumMessageSize 0 bytes  
MessageOriented False  
MinimumAddressSize 16 bytes  
PseudoStreamOriented False  
SupportsBroadcasting False  
SupportsConnectData False  
SupportsDisconnectData False  
SupportsEncryption False  
SupportsExpeditedData True  
SupportsGracefulClosing True  
SupportsGuaranteedBandwidth False  
SupportsMulticasting False

Name MSAFD Tcpi [UDP/IP]  
ConnectionlessService True  
GuaranteesDelivery False  
GuaranteesSequencing False  
MaximumAddressSize 16 bytes  
MaximumMessageSize 65467 bytes  
MessageOriented True  
MinimumAddressSize 16 bytes  
PseudoStreamOriented False  
SupportsBroadcasting True  
SupportsConnectData False  
SupportsDisconnectData False  
SupportsEncryption False  
SupportsExpeditedData False  
SupportsGracefulClosing False  
SupportsGuaranteedBandwidth False  
SupportsMulticasting True

Name RSVP UDP Service Provider  
ConnectionlessService True  
GuaranteesDelivery False  
GuaranteesSequencing False  
MaximumAddressSize 16 bytes  
MaximumMessageSize 65467 bytes  
MessageOriented True  
MinimumAddressSize 16 bytes  
PseudoStreamOriented False  
SupportsBroadcasting True  
SupportsConnectData False  
SupportsDisconnectData False  
SupportsEncryption True  
SupportsExpeditedData False  
SupportsGracefulClosing False  
SupportsGuaranteedBandwidth False  
SupportsMulticasting True

Name RSVP TCP Service Provider  
ConnectionlessService False  
GuaranteesDelivery True

## Appendix C – Tunable Parameters

---

GuaranteesSequencing True  
MaximumAddressSize 16 bytes  
MaximumMessageSize 0 bytes  
MessageOriented False  
MinimumAddressSize 16 bytes  
PseudoStreamOriented False  
SupportsBroadcasting False  
SupportsConnectData False  
SupportsDisconnectData False  
SupportsEncryption True  
SupportsExpeditedData True  
SupportsGracefulClosing True  
SupportsGuaranteedBandwidth False  
SupportsMulticasting False

Name MSAFD NetBIOS [\Device\NetBT\_Tcpip\_{0DC866E6-EF58-4EFA-B115-9F3BC62E1FD2}] SEQPACKET 0

ConnectionlessService False  
GuaranteesDelivery True  
GuaranteesSequencing True  
MaximumAddressSize 20 bytes  
MaximumMessageSize 64000 bytes  
MessageOriented True  
MinimumAddressSize 20 bytes  
PseudoStreamOriented False  
SupportsBroadcasting False  
SupportsConnectData False  
SupportsDisconnectData False  
SupportsEncryption False  
SupportsExpeditedData False  
SupportsGracefulClosing False  
SupportsGuaranteedBandwidth False  
SupportsMulticasting False

Name MSAFD NetBIOS [\Device\NetBT\_Tcpip\_{0DC866E6-EF58-4EFA-B115-9F3BC62E1FD2}] DATAGRAM 0

ConnectionlessService True  
GuaranteesDelivery False  
GuaranteesSequencing False  
MaximumAddressSize 20 bytes  
MaximumMessageSize 64000 bytes  
MessageOriented True  
MinimumAddressSize 20 bytes  
PseudoStreamOriented False  
SupportsBroadcasting True  
SupportsConnectData False  
SupportsDisconnectData False  
SupportsEncryption False  
SupportsExpeditedData False  
SupportsGracefulClosing False  
SupportsGuaranteedBandwidth False  
SupportsMulticasting False

Name MSAFD NetBIOS [\Device\NetBT\_Tcpip\_{C83532C1-86E8-4FFC-BC86-889C649D4A9A}] SEQPACKET 1

## Appendix C – Tunable Parameters

---

ConnectionlessService False  
GuaranteesDelivery True  
GuaranteesSequencing True  
MaximumAddressSize 20 bytes  
MaximumMessageSize 64000 bytes  
MessageOriented True  
MinimumAddressSize 20 bytes  
PseudoStreamOriented False  
SupportsBroadcasting False  
SupportsConnectData False  
SupportsDisconnectData False  
SupportsEncryption False  
SupportsExpeditedData False  
SupportsGracefulClosing False  
SupportsGuaranteedBandwidth False  
SupportsMulticasting False

Name MSAFD NetBIOS [\Device\NetBT\_Tcpip\_{C83532C1-86E8-4FFC-BC86-889C649D4A9A}] DATAGRAM 1

ConnectionlessService True  
GuaranteesDelivery False  
GuaranteesSequencing False  
MaximumAddressSize 20 bytes  
MaximumMessageSize 64000 bytes  
MessageOriented True  
MinimumAddressSize 20 bytes  
PseudoStreamOriented False  
SupportsBroadcasting True  
SupportsConnectData False  
SupportsDisconnectData False  
SupportsEncryption False  
SupportsExpeditedData False  
SupportsGracefulClosing False  
SupportsGuaranteedBandwidth False  
SupportsMulticasting False

Name MSAFD NetBIOS [\Device\NetBT\_Tcpip\_{E063AE69-22A9-49A3-B09C-693FC911F157}] SEQPACKET 2

ConnectionlessService False  
GuaranteesDelivery True  
GuaranteesSequencing True  
MaximumAddressSize 20 bytes  
MaximumMessageSize 64000 bytes  
MessageOriented True  
MinimumAddressSize 20 bytes  
PseudoStreamOriented False  
SupportsBroadcasting False  
SupportsConnectData False  
SupportsDisconnectData False  
SupportsEncryption False  
SupportsExpeditedData False  
SupportsGracefulClosing False  
SupportsGuaranteedBandwidth False  
SupportsMulticasting False

## Appendix C – Tunable Parameters

---

Name MSAFD NetBIOS [\\Device\NetBT\_Tcpip\_{E063AE69-22A9-49A3-B09C-693FC911F157}] DATAGRAM 2  
ConnectionlessService True  
GuaranteesDelivery False  
GuaranteesSequencing False  
MaximumAddressSize 20 bytes  
MaximumMessageSize 64000 bytes  
MessageOriented True  
MinimumAddressSize 20 bytes  
PseudoStreamOriented False  
SupportsBroadcasting True  
SupportsConnectData False  
SupportsDisconnectData False  
SupportsEncryption False  
SupportsExpeditedData False  
SupportsGracefulClosing False  
SupportsGuaranteedBandwidth False  
SupportsMulticasting False

### [WinSock]

Item Value  
File c:\winnt\system32\winsock.dll  
Version 3.10  
Size 2.80 KB (2,864 bytes)  
  
File c:\winnt\system32\wsock32.dll  
Version 5.00.2195.1207  
Size 21.27 KB (21,776 bytes)

### [Ports]

[ Following are sub-categories of this main category ]

### [Serial]

Item Value  
Name COM1  
Status OK  
PNP Device ID ACPI\PNP0501\1  
Maximum Input Buffer Size 0  
Maximum Output Buffer Size False  
Settable Baud Rate True  
Settable Data Bits True  
Settable Flow Control True  
Settable Parity True  
Settable Parity Check True  
Settable Stop Bits True  
Settable RLSD True  
Supports RLSD True  
Supports 16 Bit Mode False  
Supports Special Characters False  
Baud Rate 9600

## Appendix C – Tunable Parameters

---

Bits/Byte 8  
Stop Bits 1  
Parity None  
Busy 0  
Abort Read/Write on Error 0  
Binary Mode Enabled -1  
Continue XMit on XOff 0  
CTS Outflow Control 0  
Discard NULL Bytes 0  
DSR Outflow Control 0  
DSR Sensitivity 0  
DTR Flow Control Type Enable  
EOF Character 0  
Error Replace Character 0  
Error Replacement Enabled 0  
Event Character 0  
Parity Check Enabled 0  
RTS Flow Control Type Enable  
XOff Character 19  
XOffXMit Threshold 512  
XOn Character 17  
XOnXMit Threshold 2048  
XOnXOff InFlow Control 0  
XOnXOff OutFlow Control 0  
IRQ Number 4  
I/O Port 0x03F8-0x03FF  
Driver c:\winnt\system32\drivers\serial.sys (62448, 5.00.2134.1)

Name COM2  
Status OK  
PNP Device ID ACPI\PNP0501\2  
Maximum Input Buffer Size 0  
Maximum Output Buffer Size False  
Settable Baud Rate True  
Settable Data Bits True  
Settable Flow Control True  
Settable Parity True  
Settable Parity Check True  
Settable Stop Bits True  
Settable RLSD True  
Supports RLSD True  
Supports 16 Bit Mode False  
Supports Special Characters False  
Baud Rate 9600  
Bits/Byte 8  
Stop Bits 1  
Parity None  
Busy 0  
Abort Read/Write on Error 0  
Binary Mode Enabled -1  
Continue XMit on XOff 0  
CTS Outflow Control 0  
Discard NULL Bytes 0  
DSR Outflow Control 0  
DSR Sensitivity 0

## Appendix C – Tunable Parameters

---

DTR Flow Control Type    Enable  
EOF Character            0  
Error Replace Character 0  
Error Replacement Enabled    0  
Event Character        0  
Parity Check Enabled      0  
RTS Flow Control Type    Enable  
XOff Character          19  
XOffXmit Threshold      512  
XOn Character            17  
XOnXmit Threshold      2048  
XOnXOff InFlow Control 0  
XOnXOff OutFlow Control 0  
IRQ Number            3  
I/O Port            0x02F8-0x02FF  
Driver            c:\winnt\system32\drivers\serial.sys (62448, 5.00.2134.1)

[Parallel]

Item    Value  
Name    LPT1  
PNP Device ID    ACPI\PNP0401\4&3B8C0623&0

[Storage]

[ Following are sub-categories of this main category ]

[Drives]

Item    Value  
Drive A:  
Description 3 1/2 Inch Floppy Drive  
  
Drive C:  
Description Local Fixed Disk  
Compressed    False  
File System NTFS  
Size    8.47 GB (9,097,125,888 bytes)  
Free Space    4.34 GB (4,665,028,608 bytes)  
Volume Name  
Volume Serial Number    886E46A1  
Partition    Disk #0, Partition #0  
Partition Size    8.47 GB (9,097,127,424 bytes)  
Starting Offset    32256 bytes  
Drive Description Disk drive  
Drive Manufacturer    (Standard disk drives)  
Drive Model SEAGATE ST39102LC SCSI Disk Device  
Drive BytesPerSector    512  
Drive MediaLoaded True  
Drive MediaType    Fixed hard disk media  
Drive Partitions    1  
Drive SCSI Bus      0  
Drive SCSI LogicalUnit    0

## Appendix C – Tunable Parameters

---

Drive SCSIPort 0  
Drive SCSTargetId 0  
Drive SectorsPerTrack 63  
Drive Size 9097159680 bytes  
Drive TotalCylinders 1106  
Drive TotalSectors 17767890  
Drive TotalTracks 282030  
Drive TracksPerCylinder 255

### Drive E:

Description Local Fixed Disk  
Compressed Not Available  
File System Not Available  
Size Not Available  
Free Space Not Available  
Volume Name Not Available  
Volume Serial Number Not Available  
Partition Disk #2, Partition #0  
Partition Size 46.50 GB (49,927,417,344 bytes)  
Starting Offset 32256 bytes  
Drive Description \\.\PHYSICALDRIVE2  
Drive Manufacturer Not Available  
Drive Model Not Available  
Drive BytesPerSector 512  
Drive MediaLoaded True  
Drive MediaType Fixed hard disk media  
Drive Partitions 3  
Drive SCSIbus 4  
Drive SCSILogicalUnit 0  
Drive SCSIPort 3  
Drive SCSTargetId 0  
Drive SectorsPerTrack 63  
Drive Size 647765475840 bytes  
Drive TotalCylinders 78753  
Drive TotalSectors 1265166945  
Drive TotalTracks 20082015  
Drive TracksPerCylinder 255

### Drive F:

Description Local Fixed Disk  
Compressed Not Available  
File System Not Available  
Size Not Available  
Free Space Not Available  
Volume Name Not Available  
Volume Serial Number Not Available  
Partition Disk #2, Partition #1  
Partition Size 26.00 GB (27,916,600,320 bytes)  
Starting Offset Not Available  
Drive Description \\.\PHYSICALDRIVE2  
Drive Manufacturer Not Available  
Drive Model Not Available  
Drive BytesPerSector 512  
Drive MediaLoaded True  
Drive MediaType Fixed hard disk media

## Appendix C – Tunable Parameters

---

Drive Partitions 3  
Drive SCSIBus 4  
Drive SCSILogicalUnit 0  
Drive SCSIPort 3  
Drive SCSTargetId 0  
Drive SectorsPerTrack 63  
Drive Size 647765475840 bytes  
Drive TotalCylinders 78753  
Drive TotalSectors 1265166945  
Drive TotalTracks 20082015  
Drive TracksPerCylinder 255

### Drive G:

Description Local Fixed Disk  
Compressed Not Available  
File System Not Available  
Size Not Available  
Free Space Not Available  
Volume Name Not Available  
Volume Serial Number Not Available  
Partition Disk #3, Partition #0  
Partition Size 46.50 GB (49,927,417,344 bytes)  
Starting Offset 32256 bytes  
Drive Description \\.\PHYSICALDRIVE3  
Drive Manufacturer Not Available  
Drive Model Not Available  
Drive BytesPerSector 512  
Drive MediaLoaded True  
Drive MediaType Fixed hard disk media  
Drive Partitions 3  
Drive SCSIBus 4  
Drive SCSILogicalUnit 0  
Drive SCSIPort 4  
Drive SCSTargetId 0  
Drive SectorsPerTrack 63  
Drive Size 647765475840 bytes  
Drive TotalCylinders 78753  
Drive TotalSectors 1265166945  
Drive TotalTracks 20082015  
Drive TracksPerCylinder 255

### Drive H:

Description Local Fixed Disk  
Compressed Not Available  
File System Not Available  
Size Not Available  
Free Space Not Available  
Volume Name Not Available  
Volume Serial Number Not Available  
Partition Disk #3, Partition #1  
Partition Size 26.00 GB (27,916,600,320 bytes)  
Starting Offset Not Available  
Drive Description \\.\PHYSICALDRIVE3  
Drive Manufacturer Not Available  
Drive Model Not Available

## Appendix C – Tunable Parameters

---

Drive BytesPerSector 512  
Drive MediaLoaded True  
Drive MediaType Fixed hard disk media  
Drive Partitions 3  
Drive SCSIbus 4  
Drive SCSILogicalUnit 0  
Drive SCSIPort 4  
Drive SCSTargetId 0  
Drive SectorsPerTrack 63  
Drive Size 647765475840 bytes  
Drive TotalCylinders 78753  
Drive TotalSectors 1265166945  
Drive TotalTracks 20082015  
Drive TracksPerCylinder 255

### Drive I:

Description Local Fixed Disk  
Compressed Not Available  
File System Not Available  
Size Not Available  
Free Space Not Available  
Volume Name Not Available  
Volume Serial Number Not Available  
Partition Disk #4, Partition #0  
Partition Size 46.50 GB (49,927,417,344 bytes)  
Starting Offset 32256 bytes  
Drive Description \\.\PHYSICALDRIVE4  
Drive Manufacturer Not Available  
Drive Model Not Available  
Drive BytesPerSector 512  
Drive MediaLoaded True  
Drive MediaType Fixed hard disk media  
Drive Partitions 3  
Drive SCSIbus 4  
Drive SCSILogicalUnit 0  
Drive SCSIPort 5  
Drive SCSTargetId 0  
Drive SectorsPerTrack 63  
Drive Size 647765475840 bytes  
Drive TotalCylinders 78753  
Drive TotalSectors 1265166945  
Drive TotalTracks 20082015  
Drive TracksPerCylinder 255

### Drive J:

Description Local Fixed Disk  
Compressed Not Available  
File System Not Available  
Size Not Available  
Free Space Not Available  
Volume Name Not Available  
Volume Serial Number Not Available  
Partition Disk #4, Partition #1  
Partition Size 26.00 GB (27,916,600,320 bytes)  
Starting Offset Not Available

## Appendix C – Tunable Parameters

---

Drive Description \\.\PHYSICALDRIVE4  
Drive Manufacturer Not Available  
Drive Model Not Available  
Drive BytesPerSector 512  
Drive MediaLoaded True  
Drive MediaType Fixed hard disk media  
Drive Partitions 3  
Drive SCSIbus 4  
Drive SCSILogicalUnit 0  
Drive SCSIPort 5  
Drive SCsITargetId 0  
Drive SectorsPerTrack 63  
Drive Size 647765475840 bytes  
Drive TotalCylinders 78753  
Drive TotalSectors 1265166945  
Drive TotalTracks 20082015  
Drive TracksPerCylinder 255

Drive S:  
Description Local Fixed Disk  
Compressed Not Available  
File System Not Available  
Size Not Available  
Free Space Not Available  
Volume Name Not Available  
Volume Serial Number Not Available  
Partition Disk #1, Partition #0  
Partition Size 54.00 GB (57,979,966,464 bytes)  
Starting Offset 32256 bytes  
Drive Description \\.\PHYSICALDRIVE1  
Drive Manufacturer Not Available  
Drive Model Not Available  
Drive BytesPerSector 512  
Drive MediaLoaded True  
Drive MediaType Fixed hard disk media  
Drive Partitions 1  
Drive SCSIbus 4  
Drive SCSILogicalUnit 0  
Drive SCSIPort 2  
Drive SCsITargetId 0  
Drive SectorsPerTrack 63  
Drive Size 89959887360 bytes  
Drive TotalCylinders 10937  
Drive TotalSectors 175702905  
Drive TotalTracks 2788935  
Drive TracksPerCylinder 255

Drive U:  
Description Local Fixed Disk  
Compressed False  
File System NTFS  
Size 530.78 GB (569,921,372,160 bytes)  
Free Space 470.58 GB (505,279,741,952 bytes)  
Volume Name  
Volume Serial Number C46C90D7

## Appendix C – Tunable Parameters

---

Partition Disk #4, Partition #2  
Partition Size 530.78 GB (569,921,425,920 bytes)  
Starting Offset Not Available  
Drive Description \\.\PHYSICALDRIVE4  
Drive Manufacturer Not Available  
Drive Model Not Available  
Drive BytesPerSector 512  
Drive MediaLoaded True  
Drive MediaType Fixed hard disk media  
Drive Partitions 3  
Drive SCSIbus 4  
Drive SCSILogicalUnit 0  
Drive SCSIPort 5  
Drive SCSTargetId 0  
Drive SectorsPerTrack 63  
Drive Size 647765475840 bytes  
Drive TotalCylinders 78753  
Drive TotalSectors 1265166945  
Drive TotalTracks 20082015  
Drive TracksPerCylinder 255

### Drive X:

Description Local Fixed Disk  
Compressed False  
File System NTFS  
Size 530.78 GB (569,921,372,160 bytes)  
Free Space 470.58 GB (505,279,741,952 bytes)  
Volume Name  
Volume Serial Number 8C54BE1A  
Partition Disk #2, Partition #2  
Partition Size 530.78 GB (569,921,425,920 bytes)  
Starting Offset Not Available  
Drive Description \\.\PHYSICALDRIVE2  
Drive Manufacturer Not Available  
Drive Model Not Available  
Drive BytesPerSector 512  
Drive MediaLoaded True  
Drive MediaType Fixed hard disk media  
Drive Partitions 3  
Drive SCSIbus 4  
Drive SCSILogicalUnit 0  
Drive SCSIPort 3  
Drive SCSTargetId 0  
Drive SectorsPerTrack 63  
Drive Size 647765475840 bytes  
Drive TotalCylinders 78753  
Drive TotalSectors 1265166945  
Drive TotalTracks 20082015  
Drive TracksPerCylinder 255

### Drive Y:

Description Local Fixed Disk  
Compressed False  
File System NTFS  
Size 530.78 GB (569,921,372,160 bytes)

## Appendix C – Tunable Parameters

---

Free Space 470.58 GB (505,279,741,952 bytes)  
Volume Name  
Volume Serial Number C4600A11  
Partition Disk #3, Partition #2  
Partition Size 530.78 GB (569,921,425,920 bytes)  
Starting Offset Not Available  
Drive Description \\.\PHYSICALDRIVE3  
Drive Manufacturer Not Available  
Drive Model Not Available  
Drive BytesPerSector 512  
Drive MediaLoaded True  
Drive MediaType Fixed hard disk media  
Drive Partitions 3  
Drive SCSIbus 4  
Drive SCSILogicalUnit 0  
Drive SCSIPort 4  
Drive SCSTargetId 0  
Drive SectorsPerTrack 63  
Drive Size 647765475840 bytes  
Drive TotalCylinders 78753  
Drive TotalSectors 1265166945  
Drive TotalTracks 20082015  
Drive TracksPerCylinder 255

[SCSI]

Item Value  
Name Adaptec AIC-7899 Ultra160/m PCI SCSI Card  
Caption Adaptec AIC-7899 Ultra160/m PCI SCSI Card  
Driver adpul60m  
Status OK  
PNP Device ID  
PCI\VEN\_9005&DEV\_00CF&SUBSYS\_009C1028&REV\_01\3&13C0B0C5&0&28  
Device ID  
PCI\VEN\_9005&DEV\_00CF&SUBSYS\_009C1028&REV\_01\3&13C0B0C5&0&28  
Device Map Not Available  
Index Not Available  
Max Number Controlled Not Available  
IRQ Number 17  
I/O Port 0xF800-0xF8FF  
Driver c:\winnt\system32\drivers\adpul60m.sys (64432, v3.10a)

Name Adaptec AIC-7899 Ultra160/m PCI SCSI Card  
Caption Adaptec AIC-7899 Ultra160/m PCI SCSI Card  
Driver adpul60m  
Status OK  
PNP Device ID  
PCI\VEN\_9005&DEV\_00CF&SUBSYS\_009C1028&REV\_01\3&13C0B0C5&0&29  
Device ID  
PCI\VEN\_9005&DEV\_00CF&SUBSYS\_009C1028&REV\_01\3&13C0B0C5&0&29  
Device Map Not Available  
Index Not Available  
Max Number Controlled Not Available  
IRQ Number 18

## Appendix C – Tunable Parameters

---

I/O Port 0xF400-0xF4FF  
Driver c:\winnt\system32\drivers\adpu160m.sys (64432, v3.10a)

Name Mylex eXtremeRAID 2000 Disk Array Controller  
Caption Mylex eXtremeRAID 2000 Disk Array Controller  
Driver dac2w2k  
Status OK  
PNP Device ID  
PCI\VEN\_1069&DEV\_BA56&SUBSYS\_00401069&REV\_00\4&254DAD54&0&4040  
Device ID  
PCI\VEN\_1069&DEV\_BA56&SUBSYS\_00401069&REV\_00\4&254DAD54&0&4040  
Device Map Not Available  
Index Not Available  
Max Number Controlled Not Available  
IRQ Number 22  
I/O Port 0xDC80-0xDCFF  
Driver c:\winnt\system32\drivers\dac2w2k.sys (185488, 6.00-03)

Name Mylex eXtremeRAID 2000 Disk Array Controller  
Caption Mylex eXtremeRAID 2000 Disk Array Controller  
Driver dac2w2k  
Status OK  
PNP Device ID  
PCI\VEN\_1069&DEV\_BA56&SUBSYS\_00401069&REV\_00\4&94A037D&0&4048  
Device ID  
PCI\VEN\_1069&DEV\_BA56&SUBSYS\_00401069&REV\_00\4&94A037D&0&4048  
Device Map Not Available  
Index Not Available  
Max Number Controlled Not Available  
IRQ Number 23  
I/O Port 0xCC80-0xCCFF  
Driver c:\winnt\system32\drivers\dac2w2k.sys (185488, 6.00-03)

Name Mylex eXtremeRAID 2000 Disk Array Controller  
Caption Mylex eXtremeRAID 2000 Disk Array Controller  
Driver dac2w2k  
Status OK  
PNP Device ID  
PCI\VEN\_1069&DEV\_BA56&SUBSYS\_00401069&REV\_00\4&15BEFF34&0&4050  
Device ID  
PCI\VEN\_1069&DEV\_BA56&SUBSYS\_00401069&REV\_00\4&15BEFF34&0&4050  
Device Map Not Available  
Index Not Available  
Max Number Controlled Not Available  
IRQ Number 24  
I/O Port 0xBC80-0xBCFF  
Driver c:\winnt\system32\drivers\dac2w2k.sys (185488, 6.00-03)

Name Mylex eXtremeRAID 2000 Disk Array Controller  
Caption Mylex eXtremeRAID 2000 Disk Array Controller  
Driver dac2w2k  
Status OK  
PNP Device ID  
PCI\VEN\_1069&DEV\_BA56&SUBSYS\_00401069&REV\_00\4&18D8B19D&0&4058

## Appendix C – Tunable Parameters

---

Device ID  
PCI\VEN\_1069&DEV\_BA56&SUBSYS\_00401069&REV\_00\4&18D8B19D&0&4058  
Device Map Not Available  
Index Not Available  
Max Number Controlled Not Available  
IRQ Number 25  
I/O Port 0xAC80-0xACFF  
Driver c:\winnt\system32\drivers\dac2w2k.sys (185488, 6.00-03)

[Printing]

Name Port Name Server Name  
No printing information

[Problem Devices]

Device	PNP Device ID	Error Code
Dell 12 BAY U2W CU SCSI Processor Device	SCSI\PROCESSOR&VEN_DELL&PROD_12_BAY_U2W_CU&REV_0209\5&2D708BC0&0&0F0	28
Dell 12 BAY U2W CU SCSI Processor Device	SCSI\PROCESSOR&VEN_DELL&PROD_12_BAY_U2W_CU&REV_0209\5&2D708BC0&0&1F0	28
Dell 12 BAY U2W CU SCSI Processor Device	SCSI\PROCESSOR&VEN_DELL&PROD_12_BAY_U2W_CU&REV_0209\5&2CB960EC&0&0F0	28
Dell 12 BAY U2W CU SCSI Processor Device	SCSI\PROCESSOR&VEN_DELL&PROD_12_BAY_U2W_CU&REV_0209\5&2CB960EC&0&1F0	28
Dell 12 BAY U2W CU SCSI Processor Device	SCSI\PROCESSOR&VEN_DELL&PROD_12_BAY_U2W_CU&REV_0209\5&2CB960EC&0&3F0	28
Dell 12 BAY U2W CU SCSI Processor Device	SCSI\PROCESSOR&VEN_DELL&PROD_12_BAY_U2W_CU&REV_0209\5&3CAF76E&0&0F0	28
Dell 12 BAY U2W CU SCSI Processor Device	SCSI\PROCESSOR&VEN_DELL&PROD_12_BAY_U2W_CU&REV_0209\5&3CAF76E&0&1F0	28
Dell 12 BAY U2W CU SCSI Processor Device	SCSI\PROCESSOR&VEN_DELL&PROD_12_BAY_U2W_CU&REV_0209\5&3CAF76E&0&3F0	28
Dell 12 BAY U2W CU SCSI Processor Device	SCSI\PROCESSOR&VEN_DELL&PROD_12_BAY_U2W_CU&REV_0209\5&84D9F80&0&0F0	28
Dell 12 BAY U2W CU SCSI Processor Device	SCSI\PROCESSOR&VEN_DELL&PROD_12_BAY_U2W_CU&REV_0209\5&84D9F80&0&1F0	28
Dell 12 BAY U2W CU SCSI Processor Device	SCSI\PROCESSOR&VEN_DELL&PROD_12_BAY_U2W_CU&REV_0209\5&84D9F80&0&3F0	28

[USB]

Device	PNP Device ID
--------	---------------

## Appendix C – Tunable Parameters

---

No USB Devices

[Software Environment]

[ Following are sub-categories of this main category ]

[Drivers]

Name	Description	File	Type	Started	Start Mode	State	Status
	Error Control		Accept	Pause		Accept	Stop
abiosdsk	Abiosdsk		Not Available		Kernel Driver		False
	Disabled	Stopped	OK	Ignore	False	False	
abp480n5	abp480n5		Not Available		Kernel Driver		False
	Disabled	Stopped	OK	Normal	False	False	
acpi	Microsoft ACPI Driver	c:\winnt\system32\drivers\acpi.sys					
	Kernel Driver	True	Boot	Running	OK	Normal	False
	True						
acpiec	ACPIEC	c:\winnt\system32\drivers\acpiec.sys					
	Kernel Driver	False	Disabled	Stopped	OK	Normal	
	False	False					
adpu160m	adpu160m	c:\winnt\system32\drivers\adpu160m.sys					
	Kernel Driver	True	Boot	Running	OK	Normal	False
	True						
afd	AFD Networking Support Environment						
	c:\winnt\system32\drivers\afd.sys		Kernel Driver		True	Auto	
	Running	OK	Normal	False	True		
aha154x	Aha154x		Not Available		Kernel Driver		False
	Disabled	Stopped	OK	Normal	False	False	
aic116x	aic116x		Not Available		Kernel Driver		False
	Disabled	Stopped	OK	Normal	False	False	
aic78u2	aic78u2		Not Available		Kernel Driver		False
	Disabled	Stopped	OK	Normal	False	False	
aic78xx	aic78xx	c:\winnt\system32\drivers\aic78xx.sys					
	Kernel Driver	True	Boot	Running	OK	Normal	False
	True						
ami0nt	ami0nt		Not Available		Kernel Driver		False
	Disabled	Stopped	OK	Normal	False	False	
amsint	amsint		Not Available		Kernel Driver		False
	Disabled	Stopped	OK	Normal	False	False	
asc	asc		Not Available		Kernel Driver	False	Disabled
	Stopped	OK	Normal	False	False		
asc3350p	asc3350p		Not Available		Kernel Driver		False
	Disabled	Stopped	OK	Normal	False	False	
asc3550	asc3550		Not Available		Kernel Driver		False
	Disabled	Stopped	OK	Normal	False	False	
asyncmac	RAS Asynchronous Media Driver						
	c:\winnt\system32\drivers\asyncmac.sys		Kernel Driver			False	
	Manual	Stopped	OK	Normal	False	False	
atapi	atapi	c:\winnt\system32\drivers\atapi.sys			Kernel Driver		False
	Disabled	Stopped	OK	Normal	False	False	
atdisk	Atdisk		Not Available		Kernel Driver		False
	Disabled	Stopped	OK	Ignore	False	False	
atirage	atirage	c:\winnt\system32\drivers\atiragem.sys					
	Kernel Driver	True	Manual	Running	OK	Ignore	
	False	True					

## Appendix C – Tunable Parameters

---

```

atmarpc      ATM ARP Client Protocol
             c:\winnt\system32\drivers\atmarpc.sys      Kernel Driver      False
             Manual      Stopped      OK      Normal      False False
audstub      Audio Stub Driver c:\winnt\system32\drivers\audstub.sys
             Kernel Driver      True Manual      Running      OK      Normal
             False True
beep         Beep c:\winnt\system32\drivers\beep.sys  Kernel Driver      True
             System      Running      OK      Normal      False True
buslogic     BusLogic Not Available Kernel Driver      False
             Disabled Stopped      OK      Normal      False False
cd20xrnt     cd20xrnt Not Available Kernel Driver      False
             Disabled Stopped      OK      Normal      False False
cdaudio      Cdaudio c:\winnt\system32\drivers\cdaudio.sys
             Kernel Driver      False System      Stopped      OK      Ignore
             False False
cdfs         Cdfs c:\winnt\system32\drivers\cdfs.sys  File System Driver
             False Disabled Stopped      OK      Normal      False False
cdrom        CD-ROM Driver c:\winnt\system32\drivers\cdrom.sys Kernel
Driver      False System      Stopped      OK      Normal      False False
changer      Changer Not Available Kernel Driver      False
             System      Stopped      OK      Ignore      False False
cpqarray     Cpqarray Not Available Kernel Driver      False
             Disabled Stopped      OK      Normal      False False
cpqarray2    cpqarray2 Not Available Kernel Driver      False
             Disabled Stopped      OK      Normal      False False
cpqfcalm     cpqfcalm Not Available Kernel Driver      False
             Disabled Stopped      OK      Normal      False False
cpqfws2e     cpqfws2e Not Available Kernel Driver      False
             Disabled Stopped      OK      Normal      False False
dac2w2k      dac2w2k c:\winnt\system32\drivers\dac2w2k.sys
             Kernel Driver      True Boot Running      OK      Normal      False
             True
dac960nt     dac960nt Not Available Kernel Driver      False
             Disabled Stopped      OK      Normal      False False
deckzpsx     deckzpsx Not Available Kernel Driver      False
             Disabled Stopped      OK      Normal      False False
dfsdriver    DfsDriver c:\winnt\system32\drivers\dfs.sys  File System
Driver      True Boot Running      OK      Normal      False True
disk         Disk Driver c:\winnt\system32\drivers\disk.sys  Kernel Driver
             True Boot Running      OK      Normal      False True
diskperf     Diskperf c:\winnt\system32\drivers\diskperf.sys
             Kernel Driver      False Disabled Stopped      OK      Normal
             False False
dmboot       dmboot c:\winnt\system32\drivers\dmboot.sys
             Kernel Driver      False Disabled Stopped      OK      Normal
             False False
dmio         Logical Disk Manager Driver c:\winnt\system32\drivers\dmio.sys
             Kernel Driver      True Boot Running      OK      Normal      False
             True
dmload       dmload c:\winnt\system32\drivers\dmload.sys
             Kernel Driver      True Boot Running      OK      Normal      False
             True
e1000        Intel(R) PRO/1000 Gigabit Server Adapter Driver
             c:\winnt\system32\drivers\e1000nt5.sys  Kernel Driver      False
             Manual      Stopped      OK      Normal      False False

```

## Appendix C – Tunable Parameters

---

```

e100b Intel PRO Adapter Driver
      c:\winnt\system32\drivers\e100bnt5.sys   Kernel Driver   True
      Manual      Running      OK      Normal      False True
efs    EFS      c:\winnt\system32\drivers\efs.sys   File System Driver
      True Disabled      Running      OK      Normal      False True
fastfat Fastfat      c:\winnt\system32\drivers\fastfat.sys   File
System Driver      True Disabled      Running      OK      Normal      False
True
fd16_700 Fd16_700      Not Available      Kernel Driver      False
      Disabled      Stopped      OK      Normal      False False
fdc    Floppy Disk Controller Driver c:\winnt\system32\drivers\fdc.sys
      Kernel Driver      True Manual      Running      OK      Normal
      False True
fireport fireport      Not Available      Kernel Driver      False
      Disabled      Stopped      OK      Normal      False False
flashpnt flashpnt      Not Available      Kernel Driver      False
      Disabled      Stopped      OK      Normal      False False
flpydisk Floppy Disk Driver
      c:\winnt\system32\drivers\flpydisk.sys   Kernel Driver      True
      Manual      Running      OK      Normal      False True
ftdisk Volume Manager Driver
      c:\winnt\system32\drivers\ftdisk.sys     Kernel Driver      True
      Boot Running      OK      Normal      False True
gamdrv gamdrv      c:\winnt\system32\drivers\gamdrv.sys
      Kernel Driver      True Boot Running      OK      Normal      False
      True
gnindis cLAN NDIS Driver c:\winnt\system32\drivers\gnindis.sys
      Kernel Driver      False Auto Stopped      OK      Normal      False
      False
gnivia cLAN VIA Driver c:\winnt\system32\drivers\gnivia.sys
      Kernel Driver      True Auto Running      OK      Normal      False
      True
gpc    Generic Packet Classifier      c:\winnt\system32\drivers\msgpc.sys
      Kernel Driver      True Manual      Running      OK      Normal
      False True
i8042prt i8042 Keyboard and PS/2 Mouse Port Driver
      c:\winnt\system32\drivers\i8042prt.sys   Kernel Driver      True
      System Running      OK      Normal      False True
ini910u ini910u      Not Available      Kernel Driver      False
      Disabled      Stopped      OK      Normal      False False
intelide IntelIde      Not Available      Kernel Driver      False
      Disabled      Stopped      OK      Normal      False False
ipfilterdriver IP Traffic Filter Driver
      c:\winnt\system32\drivers\ipfltdrv.sys   Kernel Driver      False
      Manual      Stopped      OK      Normal      False False
ipinip IP in IP Tunnel Driver
      c:\winnt\system32\drivers\ipinip.sys     Kernel Driver      False
      Manual      Stopped      OK      Normal      False False
ipnat IP Network Address Translator c:\winnt\system32\drivers\ipnat.sys
      Kernel Driver      False Manual      Stopped      OK      Normal
      False False
ipsec IPSEC driver      c:\winnt\system32\drivers\ipsec.sys Kernel
Driver      False Manual      Stopped      OK      Normal      False False
ipsraidn ipsraidn      Not Available      Kernel Driver      False
      Disabled      Stopped      OK      Normal      False False

```

## Appendix C – Tunable Parameters

---

```

isapnp      PnP ISA/EISA Bus Driver
            c:\winnt\system32\drivers\isapnp.sys      Kernel Driver      True
            Boot Running      OK      Critical      False True
kbdclass    Keyboard Class Driver
            c:\winnt\system32\drivers\kbdclass.sys    Kernel Driver      True
            System      Running      OK      Normal      False True
ksecdd      KSecDD      c:\winnt\system32\drivers\ksecdd.sys
            Kernel Driver      True Boot Running      OK      Normal      False
            True
lbrtfdc     lbrtfdc     Not Available      Kernel Driver      False
            System      Stopped      OK      Ignore      False False
lp6nds35    lp6nds35    Not Available      Kernel Driver      False
            Disabled      Stopped      OK      Normal      False False
macdisk     macdisk     c:\winnt\system32\drivers\mac2w2k.sys
            Kernel Driver      True Boot Running      OK      Normal      False
            True
mnmdd       mnmdd      c:\winnt\system32\drivers\mnmdd.sys Kernel Driver      True
            System      Running      OK      Ignore      False True
modem       Modem      c:\winnt\system32\drivers\modem.sys Kernel Driver      False
            Manual      Stopped      OK      Ignore      False False
mouclass    Mouse Class Driver
            c:\winnt\system32\drivers\mouclass.sys    Kernel Driver      True
            System      Running      OK      Normal      False True
mountmgr    MountMgr    c:\winnt\system32\drivers\mountmgr.sys
            Kernel Driver      True Boot Running      OK      Normal      False
            True
mraid35x    mraid35x    Not Available      Kernel Driver      False
            Disabled      Stopped      OK      Normal      False False
mrxsmb      MRXSMB      c:\winnt\system32\drivers\mrxsmb.sys      File
            System Driver      True System      Running      OK      Normal      False
            True
msfs        Msfs      c:\winnt\system32\drivers\msfs.sys File System Driver
            True System      Running      OK      Normal      False True
mskssrv     Microsoft Streaming Service Proxy
            c:\winnt\system32\drivers\mskssrv.sys      Kernel Driver      False
            Manual      Stopped      OK      Normal      False False
mspclock    Microsoft Streaming Clock Proxy
            c:\winnt\system32\drivers\mspclock.sys      Kernel Driver      False
            Manual      Stopped      OK      Normal      False False
mspqm       Microsoft Streaming Quality Manager Proxy
            c:\winnt\system32\drivers\mspqm.sys Kernel Driver      False
            Manual      Stopped      OK      Normal      False False
mup         Mup      c:\winnt\system32\drivers\mup.sys File System Driver
            True Boot Running      OK      Normal      False True
ncrc710     Ncrc710    Not Available      Kernel Driver      False
            Disabled      Stopped      OK      Normal      False False
ndis        NDIS System Driver      c:\winnt\system32\drivers\ndis.sys
            Kernel Driver      True Boot Running      OK      Normal      False
            True
ndistapi    Remote Access NDIS TAPI Driver
            c:\winnt\system32\drivers\ndistapi.sys      Kernel Driver      True
            Manual      Running      OK      Normal      False True
ndiswan     Remote Access NDIS WAN Driver
            c:\winnt\system32\drivers\ndiswan.sys      Kernel Driver      True
            Manual      Running      OK      Normal      False True

```

## Appendix C – Tunable Parameters

---

```

ndproxy      NDIS Proxy      c:\winnt\system32\drivers\ndproxy.sys
              Kernel Driver      True Manual      Running      OK      Normal
              False True

netbios      NetBIOS Interface c:\winnt\system32\drivers\netbios.sys
              File System Driver      True System      Running      OK
              Normal      False True

netbt NetBios over Tcpip      c:\winnt\system32\drivers\netbt.sys
              Kernel Driver      True System      Running      OK      Normal
              False True

netdetect NetDetect      c:\winnt\system32\drivers\netdtect.sys
              Kernel Driver      False Manual      Stopped      OK      Normal
              False False

npfs Npfs      c:\winnt\system32\drivers\npfs.sys File System Driver
              True System      Running      OK      Normal      False True

ntfs Ntfs      c:\winnt\system32\drivers\ntfs.sys File System Driver
              True Disabled      Running      OK      Normal      False True

null Null      c:\winnt\system32\drivers\null.sys Kernel Driver      True
              System      Running      OK      Normal      False True

nwlkflt      IPX Traffic Filter Driver
              c:\winnt\system32\drivers\nwlkflt.sys Kernel Driver      False
              Manual      Stopped      OK      Normal      False False

nwlk fwd      IPX Traffic Forwarder Driver
              c:\winnt\system32\drivers\nwlk fwd.sys Kernel Driver      False
              Manual      Stopped      OK      Normal      False False

parallel      Parallel class driver
              c:\winnt\system32\drivers\parallel.sys Kernel Driver      True
              Manual      Running      OK      Normal      False True

parport      Parallel port driver
              c:\winnt\system32\drivers\parport.sys Kernel Driver      True
              System      Running      OK      Ignore      False True

partmgr      PartMgr      c:\winnt\system32\drivers\partmgr.sys
              Kernel Driver      True Boot Running      OK      Normal      False
              True

parvdm      ParVdm      c:\winnt\system32\drivers\parvdm.sys
              Kernel Driver      True Auto Running      OK      Ignore      False
              True

pci PCI Bus Driver      c:\winnt\system32\drivers\pci.sys Kernel
Driver      True Boot Running      OK      Critical      False True

pcidump      PCIDump      Not Available      Kernel Driver      False
              System      Stopped      OK      Ignore      False False

pciide      PCIIDE      Not Available      Kernel Driver      False
              Disabled      Stopped      OK      Normal      False False

pcmcia      Pcmcia      c:\winnt\system32\drivers\pcmcia.sys
              Kernel Driver      False Disabled      Stopped      OK      Normal
              False False

pdcomp      PDCOMP      Not Available      Kernel Driver      False
              Manual      Stopped      OK      Ignore      False False

pdframe      PDFRAME      Not Available      Kernel Driver      False
              Manual      Stopped      OK      Ignore      False False

pdreli      PDRELI      Not Available      Kernel Driver      False
              Manual      Stopped      OK      Ignore      False False

pdrframe      PDRFRAME      Not Available      Kernel Driver      False
              Manual      Stopped      OK      Ignore      False False

```

## Appendix C – Tunable Parameters

---

```

pptpminiport      WAN Miniport (PPTP)
  c:\winnt\system32\drivers\rasppptp.sys  Kernel Driver  True
  Manual      Running      OK      Normal      False True
ptilink          Direct Parallel Link Driver
  c:\winnt\system32\drivers\ptilink.sys    Kernel Driver  True
  Manual      Running      OK      Normal      False True
ql1080          ql1080      Not Available  Kernel Driver  False
  Disabled   Stopped      OK      Normal      False False
ql10wnt        Ql10wnt      Not Available  Kernel Driver  False
  Disabled   Stopped      OK      Normal      False False
ql1240          ql1240      Not Available  Kernel Driver  False
  Disabled   Stopped      OK      Normal      False False
ql2100          ql2100      Not Available  Kernel Driver  False
  Disabled   Stopped      OK      Normal      False False
ql2200          ql2200      c:\winnt\system32\drivers\ql2200.sys
  Kernel Driver  True Boot Running  OK      Normal      False
  True
rasacd          Remote Access Auto Connection Driver
  c:\winnt\system32\drivers\rasacd.sys    Kernel Driver  True
  System      Running      OK      Normal      False True
rasl2tp         WAN Miniport (L2TP)
  c:\winnt\system32\drivers\rasl2tp.sys   Kernel Driver  True
  Manual      Running      OK      Normal      False True
raspti          Direct Parallel  c:\winnt\system32\drivers\raspti.sys
  Kernel Driver  True Manual      Running      OK      Normal
  False True
rca             Microsoft Streaming Network Raw Channel Access
  c:\winnt\system32\drivers\rca.sys       Kernel Driver  False
  Manual      Stopped      OK      Normal      False False
rdbss          Rdbss c:\winnt\system32\drivers\rdbss.sys File System Driver
  True System      Running      OK      Normal      False True
rdpwd          RDPWD c:\winnt\system32\drivers\rdpwd.sys Kernel Driver  False
  Manual      Stopped      OK      Ignore      False False
redbook        Digital CD Audio Playback Filter Driver
  c:\winnt\system32\drivers\redbook.sys   Kernel Driver  False
  System      Stopped      OK      Normal      False False
serenum        Serenum Filter Driver
  c:\winnt\system32\drivers\serenum.sys   Kernel Driver  True
  Manual      Running      OK      Normal      False True
serial         Serial port driver
  c:\winnt\system32\drivers\serial.sys     Kernel Driver  True
  System      Running      OK      Ignore      False True
sfloppy        Sfloppy c:\winnt\system32\drivers\sfloppy.sys
  Kernel Driver  False System      Stopped      OK      Ignore
  False False
sglfb          sglfb Not Available  Kernel Driver  False System
  Stopped      OK      Normal      False False
simbad         Simbad      Not Available  Kernel Driver  False
  Disabled   Stopped      OK      Normal      False False
sparrow        Sparrow      Not Available  Kernel Driver  False
  Disabled   Stopped      OK      Normal      False False
srv            Srv c:\winnt\system32\drivers\srv.sys File System Driver
  True Manual      Running      OK      Normal      False True

```

## Appendix C – Tunable Parameters

---

```

swenum      Software Bus Driver
             c:\winnt\system32\drivers\swenum.sys      Kernel Driver      True
             Manual      Running      OK      Normal      False True
symc810     symc810      Not Available      Kernel Driver      False
             Disabled    Stopped      OK      Normal      False False
symc8xx     symc8xx      Not Available      Kernel Driver      False
             Disabled    Stopped      OK      Normal      False False
sym_hi      sym_hi      Not Available      Kernel Driver      False
             Disabled    Stopped      OK      Normal      False False
tcpip       TCP/IP Protocol Driver  c:\winnt\system32\drivers\tcpip.sys
             Kernel Driver      True System      Running      OK      Normal
             False True
tdasync     TDASYNC      c:\winnt\system32\drivers\tdasync.sys
             Kernel Driver      False Manual      Stopped      OK      Ignore
             False False
tdipx       TDIPX      c:\winnt\system32\drivers\tdipx.sys Kernel Driver      False
             Manual      Stopped      OK      Ignore      False False
tdnetb      TDNETB      c:\winnt\system32\drivers\tdnetb.sys
             Kernel Driver      False Manual      Stopped      OK      Ignore
             False False
tdpipe      TDPIPE      c:\winnt\system32\drivers\tdpipe.sys
             Kernel Driver      False Manual      Stopped      OK      Ignore
             False False
tdspx       TDSPX      c:\winnt\system32\drivers\tdspx.sys Kernel Driver      False
             Manual      Stopped      OK      Ignore      False False
tdtcp       TDTCP      c:\winnt\system32\drivers\tdtcp.sys Kernel Driver      False
             Manual      Stopped      OK      Ignore      False False

termdd      Terminal Device Driver
             c:\winnt\system32\drivers\termdd.sys      Kernel Driver      False
             Disabled    Stopped      OK      Normal      False False
tga         tga      Not Available      Kernel Driver      False System
             Stopped      OK      Ignore      False False
udfs        Udfs      c:\winnt\system32\drivers\udfs.sys File System Driver
             False Disabled    Stopped      OK      Normal      False False
ultra66     ultra66     Not Available      Kernel Driver      False
             Disabled    Stopped      OK      Normal      False False
update      Microcode Update Driver
             c:\winnt\system32\drivers\update.sys      Kernel Driver      True
             Manual      Running      OK      Normal      False True
vgasave    VgaSave      c:\winnt\system32\drivers\vga.sys Kernel
Driver      True System      Running      OK      Ignore      False True
wanarp      Remote Access IP ARP Driver
             c:\winnt\system32\drivers\wanarp.sys      Kernel Driver      True
             Manual      Running      OK      Normal      False True
wdica       WDICA      Not Available      Kernel Driver      False Manual
             Stopped      OK      Ignore      False False

```

### [Environment Variables]

```

Variable    Value User Name
ComSpec     %SystemRoot%\system32\cmd.exe <SYSTEM>
HOME        C:/      <SYSTEM>
NUMBER_OF_PROCESSORS  4      <SYSTEM>
OS          Windows_NT <SYSTEM>

```

## Appendix C – Tunable Parameters

---

```

Os2LibPath %SystemRoot%\system32\os2\dll; <SYSTEM>
Path
    C:\MKS\mksnt;C:\WINNT\system32;C:\WINNT;C:\WINNT\System32\Wbem;C:
\PROGRA~1\MICROS~2\80\Tools\BINN;C:\Program Files\Microsoft SQL
Server\MSSQL\Binn;. ; <SYSTEM>
PATHEXT .COM;.EXE;.BAT;.CMD;.VBS;.VBE;.JS;.JSE;.WSF;.WSH
<SYSTEM>
PROCESSOR_ARCHITECTURE x86 <SYSTEM>
PROCESSOR_IDENTIFIER x86 Family 6 Model 10 Stepping 0, GenuineIntel
<SYSTEM>
PROCESSOR_LEVEL 6 <SYSTEM>
PROCESSOR_REVISION 0a00 <SYSTEM>
ROOTDIR C:/MKS <SYSTEM>
SHELL C:/MKS/mksnt/sh.exe <SYSTEM>
TEMP %SystemRoot%\TEMP <SYSTEM>
TMP %SystemRoot%\TEMP <SYSTEM>
TMPDIR C:/WINNT/TEMP <SYSTEM>
windir %SystemRoot% <SYSTEM>
TEMP %USERPROFILE%\Local Settings\Temp PE6400_01\Administrator
TMP %USERPROFILE%\Local Settings\Temp PE6400_01\Administrator

```

[Jobs]

[ Following are sub-categories of this main category ]

[Print]

Document	Size	Owner	Notify	Status	Time Submitted	Start
Time	Until Time	Elapsed Time	Pages Printed	Job ID	Host	Print
Priority	Parameters	Driver Name	Print Processor	Host	Print	
Queue Data Type	Name					
Unknown	Unknown	Unknown	Unknown	Unknown	Unknown	Unknown
Unknown	Unknown	Unknown	Unknown	Unknown	Unknown	Unknown
Unknown	Unknown	Unknown	Unknown	Unknown	Unknown	Unknown
Unknown	Unknown	Unknown	Unknown	Unknown	Unknown	Unknown

[Network Connections]

Local Name	Remote Name	Type	Status	User Name
No network connections information				

[Running Tasks]

Name	Path	Process ID	Priority	Min Working Set	Max Working Set
Start Time	Version	Size	File Date		
system	idle process	Not Available	0	0	Not Available
Unknown	Not Available	Not Available	Unknown	Unknown	Unknown
system	Not Available	8	8	0	1413120
Available	Unknown	Unknown	Unknown		Not
smss.exe	c:\winnt\system32\smss.exe	172	11	204800	
	1413120	10/12/2000 11:49:47 AM	5.00.2195.31		44.27 KB
	(45,328 bytes)	12/7/1999 6:00:00 AM			
csrss.exe	Not Available	196	13	Not Available	Not
Available	10/12/2000 11:49:51 AM	Unknown	Unknown	Unknown	Unknown

## Appendix C – Tunable Parameters

---

```

winlogon.exe      c:\winnt\system32\winlogon.exe      216  13
                204800      1413120      10/12/2000 11:49:52 AM 5.00.2195.1600
                172.77 KB (176,912 bytes)      12/7/1999 6:00:00 AM
services.exe     c:\winnt\system32\services.exe      244  9
                204800      1413120      10/12/2000 11:49:54 AM 5.00.2134.1 86.77
KB (88,848 bytes) 12/7/1999 6:00:00 AM
lsass.exe        c:\winnt\system32\lsass.exe         256  13      204800
                1413120      10/12/2000 11:49:54 AM 5.00.2195.1620      32.77 KB
(33,552 bytes)   12/7/1999 6:00:00 AM
svchost.exe     c:\winnt\system32\svchost.exe       412  8      204800
                1413120      10/12/2000 11:49:57 AM 5.00.2134.1 7.77 KB (7,952
bytes)           12/7/1999 6:00:00 AM
svchost.exe     c:\winnt\system32\svchost.exe       612  8      204800
                1413120      10/12/2000 11:50:00 AM 5.00.2134.1 7.77 KB (7,952
bytes)           12/7/1999 6:00:00 AM
winmgmt.exe     c:\winnt\system32\wbem\winmgmt.exe  628  8      204800
                1413120      10/12/2000 11:50:01 AM 1.50.1085.0009      192.08 KB
(196,685 bytes) 9/15/2000 3:20:22 PM
explorer.exe    c:\winnt\explorer.exe              732  8      204800
                1413120      10/12/2000 11:50:09 AM 5.00.3103.1000      237.27 KB
(242,960 bytes) 9/15/2000 3:20:20 PM
svchost.exe     c:\winnt\system32\svchost.exe       900  8      204800
                1413120      10/12/2000 11:50:16 AM 5.00.2134.1 7.77 KB (7,952
bytes)           12/7/1999 6:00:00 AM
cmd.exe         c:\winnt\system32\cmd.exe           948  8      204800
                1413120      10/13/2000 6:39:49 PM 5.00.2195.1600      230.77 KB
(236,304 bytes) 12/7/1999 6:00:00 AM
mmc.exe         c:\winnt\system32\mmc.exe           672  8      204800
                1413120      10/15/2000 5:00:53 PM 5.00.2153.1 589.27 KB
(603,408 bytes) 12/7/1999 6:00:00 AM
rsvp.exe        c:\winnt\system32\rsvp.exe          684  8      204800
                1413120      10/15/2000 5:02:14 PM 5.00.2167.1 172.77 KB
(176,912 bytes) 12/7/1999 6:00:00 AM

```

[Loaded Modules]

```

Name Version      Size File Date      Manufacturer      Path
traffic.dll 5.00.2139.1 30.77 KB (31,504 bytes) 12/7/1999 6:00:00 AM
                Microsoft Corporation c:\winnt\system32\traffic.dll
rsvp.exe    5.00.2167.1 172.77 KB (176,912 bytes) 12/7/1999 6:00:00
AM          Microsoft Corporation c:\winnt\system32\rsvp.exe
wbemprox.dll 1.50.1085.0015 40.08 KB (41,040 bytes) 9/15/2000
3:20:23 PM Microsoft Corporation c:\winnt\system32\wbem\wbemprox.dll
mlang.dll 5.00.3103.1000 510.77 KB (523,024 bytes) 9/15/2000
3:20:13 PM Microsoft Corporation c:\winnt\system32\mlang.dll
rassapi.dll 5.00.2188.1 14.27 KB (14,608 bytes) 12/7/1999 6:00:00 AM
                Microsoft Corporation c:\winnt\system32\rassapi.dll
adsnt.dll 5.00.2195.1600 194.27 KB (198,928 bytes) 9/15/2000
3:20:18 PM Microsoft Corporation c:\winnt\system32\adsnt.dll
dbghelp.dll 5.00.2195.1 159.27 KB (163,088 bytes) 12/7/1999 6:00:00
AM          Microsoft Corporation c:\winnt\system32\dbghelp.dll
localsec.dll 5.00.2195.1340 227.27 KB (232,720 bytes)
9/15/2000 3:20:13 PM Microsoft Corporation
                c:\winnt\system32\localsec.dll

```

## Appendix C – Tunable Parameters

---

devmgr.dll 5.00.2166.1 215.77 KB (220,944 bytes) 12/7/1999 6:00:00 AM Microsoft Corporation c:\winnt\system32\devmgr.dll  
filemgmt.dll 5.00.2134.1 287.27 KB (294,160 bytes) 12/7/1999 6:00:00 AM Microsoft Corporation c:\winnt\system32\filemgmt.dll  
pdh.dll 5.00.2195.1600 143.27 KB (146,704 bytes) 9/15/2000 3:20:09 PM Microsoft Corporation c:\winnt\system32\pdh.dll  
smlogcfg.dll 5.00.2163.1 273.27 KB (279,824 bytes) 12/7/1999 6:00:00 AM Microsoft Corporation c:\winnt\system32\smlogcfg.dll  
cabinet.dll 5.00.2147.1 54.77 KB (56,080 bytes) 12/7/1999 6:00:00 AM Microsoft Corporation c:\winnt\system32\cabinet.dll  
msinfo32.dll 5.00.2177.1 312.27 KB (319,760 bytes) 9/13/2000 11:18:01 AM Microsoft Corporation c:\program files\common files\microsoft shared\msinfo\msinfo32.dll  
riched20.dll 5.30.23.1203 421.27 KB (431,376 bytes) 9/15/2000 3:20:08 PM Microsoft Corporation c:\winnt\system32\riched20.dll  
riched32.dll 5.00.2134.1 3.77 KB (3,856 bytes) 12/7/1999 6:00:00 AM Microsoft Corporation c:\winnt\system32\riched32.dll  
els.dll 5.00.2175.1 151.27 KB (154,896 bytes) 12/7/1999 6:00:00 AM Microsoft Corporation c:\winnt\system32\els.dll  
ntmsmgr.dll 1,0,0,1 427.77 KB (438,032 bytes) 12/7/1999 6:00:00 AM Microsoft Corporation and HighGround Systems, Inc. c:\winnt\system32\ntmsmgr.dll  
mmfutil.dll 1.50.1085.0000 32.06 KB (32,829 bytes) 12/7/1999 6:00:00 AM Microsoft Corporation c:\winnt\system32\mmfutil.dll  
logdrive.dll 1.50.1085.0000 200.06 KB (204,863 bytes) 12/7/1999 6:00:00 AM Microsoft Corporation c:\winnt\system32\logdrive.dll  
dfrgres.dll 5.00.2150.1 27.50 KB (28,160 bytes) 12/7/1999 6:00:00 AM Executive Software International, Inc. c:\winnt\system32\dfrgres.dll  
dfrgsnap.dll 5.00.2195.31 41.77 KB (42,768 bytes) 9/15/2000 3:20:16 PM Executive Software International, Inc. c:\winnt\system32\dfrgsnap.dll  
dmdskres.dll 2191.1.296.2 119.00 KB (121,856 bytes) 12/7/1999 6:00:00 AM Microsoft Corp., VERITAS Software c:\winnt\system32\dmdskres.dll  
dmutil.dll 2195.23.297.2 42.27 KB (43,280 bytes) 9/15/2000 3:20:16 PM VERITAS Software Corp. c:\winnt\system32\dmutil.dll  
ntmsapi.dll 5.00.1948.1 50.27 KB (51,472 bytes) 9/15/2000 3:20:09 PM Microsoft Corporation c:\winnt\system32\ntmsapi.dll  
dmdskmgr.dll 2195.1600.297.3 160.27 KB (164,112 bytes) 9/15/2000 3:20:16 PM Microsoft Corp., VERITAS Software c:\winnt\system32\dmdskmgr.dll  
mycomput.dll 5.00.2134.1 107.77 KB (110,352 bytes) 12/7/1999 6:00:00 AM Microsoft Corporation c:\winnt\system32\mycomput.dll  
comdlg32.dll 5.00.3103.1000 236.77 KB (242,448 bytes) 12/7/1999 6:00:00 AM Microsoft Corporation c:\winnt\system32\comdlg32.dll  
mmcndmgr.dll 5.00.2178.1 815.27 KB (834,832 bytes) 12/7/1999 6:00:00 AM Microsoft Corporation c:\winnt\system32\mmcndmgr.dll  
msvcp50.dll 5.00.7051 552.50 KB (565,760 bytes) 12/7/1999 6:00:00 AM Microsoft Corporation c:\winnt\system32\msvcp50.dll  
mfc42u.dll 6.00.8665.0 972.05 KB (995,384 bytes) 12/7/1999 6:00:00 AM Microsoft Corporation c:\winnt\system32\mfc42u.dll

## Appendix C – Tunable Parameters

---

```
mmc.exe      5.00.2153.1 589.27 KB (603,408 bytes)      12/7/1999 6:00:00
AM Microsoft Corporation c:\winnt\system32\mmc.exe
cmd.exe      5.00.2195.1600 230.77 KB (236,304 bytes)      12/7/1999
6:00:00 AM Microsoft Corporation c:\winnt\system32\cmd.exe
tapisrv.dll 5.00.2186.1 168.77 KB (172,816 bytes)      12/7/1999 6:00:00
AM Microsoft Corporation c:\winnt\system32\tapisrv.dll
faxshell.dll 5.00.2134.1 8.27 KB (8,464 bytes)      12/7/1999 6:00:00
AM Microsoft Corporation c:\winnt\system32\faxshell.dll
msacm32.dll 5.00.2134.1 65.27 KB (66,832 bytes) 12/7/1999 6:00:00 AM
Microsoft Corporation c:\winnt\system32\msacm32.dll
avifil32.dll 5.00.2134.1 76.27 KB (78,096 bytes) 12/7/1999 6:00:00
AM Microsoft Corporation c:\winnt\system32\avifil32.dll
msvfw32.dll 5.00.2134.1 113.77 KB (116,496 bytes) 12/7/1999 6:00:00
AM Microsoft Corporation c:\winnt\system32\msvfw32.dll
docprop2.dll 5.00.2178.1 297.77 KB (304,912 bytes) 12/7/1999
6:00:00 AM Microsoft Corporation c:\winnt\system32\docprop2.dll
query.dll 5.00.2195.1600 1.35 MB (1,411,344 bytes) 9/15/2000
3:20:08 PM Microsoft Corporation c:\winnt\system32\query.dll
wininet.dll 5.00.3103.1000 456.77 KB (467,728 bytes) 9/15/2000
3:20:06 PM Microsoft Corporation c:\winnt\system32\wininet.dll
shdoclc.dll 5.00.3103.1000 324.50 KB (332,288 bytes) 9/15/2000
3:20:07 PM Microsoft Corporation c:\winnt\system32\shdoclc.dll
mydocs.dll 5.00.2920.0000 55.77 KB (57,104 bytes) 12/7/1999 6:00:00
AM Microsoft Corporation c:\winnt\system32\mydocs.dll
urlmon.dll 5.00.3103.1000 440.77 KB (451,344 bytes) 9/15/2000
3:20:06 PM Microsoft Corporation c:\winnt\system32\urlmon.dll
ntshrui.dll 5.00.2134.1 46.77 KB (47,888 bytes) 12/7/1999 6:00:00 AM
Microsoft Corporation c:\winnt\system32\ntshrui.dll
linkinfo.dll 5.00.2134.1 15.77 KB (16,144 bytes) 12/7/1999 6:00:00
AM Microsoft Corporation c:\winnt\system32\linkinfo.dll
powrprof.dll 5.00.3103.1000 13.27 KB (13,584 bytes) 9/15/2000
3:20:08 PM Microsoft Corporation c:\winnt\system32\powrprof.dll
batmeter.dll 5.00.2920.0000 20.27 KB (20,752 bytes) 9/15/2000
3:20:18 PM Microsoft Corporation c:\winnt\system32\batmeter.dll
stobject.dll 5.00.2195.1387 79.27 KB (81,168 bytes) 9/15/2000
3:20:07 PM Microsoft Corporation c:\winnt\system32\stobject.dll
webcheck.dll 5.00.3103.1000 251.77 KB (257,808 bytes)
9/15/2000 3:20:06 PM Microsoft Corporation
c:\winnt\system32\webcheck.dll
browselc.dll 5.00.3103.1000 34.50 KB (35,328 bytes) 9/15/2000
3:20:18 PM Microsoft Corporation c:\winnt\system32\browselc.dll
browseui.dll 5.00.3103.1000 788.77 KB (807,696 bytes)
9/15/2000 3:20:18 PM Microsoft Corporation
c:\winnt\system32\browseui.dll
shdocvw.dll 5.00.3103.1000 1.05 MB (1,104,144 bytes) 9/15/2000
3:20:07 PM Microsoft Corporation c:\winnt\system32\shdocvw.dll
explorer.exe 5.00.3103.1000 237.27 KB (242,960 bytes)
9/15/2000 3:20:20 PM Microsoft Corporation
c:\winnt\explorer.exe
netui1.dll 5.00.2134.1 210.27 KB (215,312 bytes) 12/7/1999 6:00:00
AM Microsoft Corporation c:\winnt\system32\netui1.dll
netui0.dll 5.00.2134.1 70.27 KB (71,952 bytes) 12/7/1999 6:00:00 AM
Microsoft Corporation c:\winnt\system32\netui0.dll
ntlanman.dll 5.00.2157.1 35.27 KB (36,112 bytes) 12/7/1999 6:00:00
AM Microsoft Corporation c:\winnt\system32\ntlanman.dll
```

## Appendix C – Tunable Parameters

---

```
wshnetbs.dll      5.00.2134.1 7.77 KB (7,952 bytes) 12/7/1999 6:00:00
AM Microsoft Corporation c:\winnt\system32\wshnetbs.dll
rapilib.dll 5.00.2167.1 25.27 KB (25,872 bytes) 12/7/1999 6:00:00 AM
Microsoft Corporation c:\winnt\system32\rapilib.dll
rsvpsp.dll 5.00.2167.1 74.77 KB (76,560 bytes) 12/7/1999 6:00:00 AM
Microsoft Corporation c:\winnt\system32\rsvpsp.dll
ntmarta.dll 5.00.2158.1 98.77 KB (101,136 bytes) 12/7/1999 6:00:00
AM Microsoft Corporation c:\winnt\system32\ntmarta.dll
provthrd.dll 1.50.1085.0000 68.07 KB (69,708 bytes) 9/13/2000
11:17:53 AM Microsoft Corporation c:\winnt\system32\wbem\provthrd.dll
ntevt.dll 1.50.1085.0000 192.06 KB (196,669 bytes) 12/7/1999
6:00:00 AM Microsoft Corporation c:\winnt\system32\wbem\ntevt.dll
perfos.dll 5.00.2155.1 21.27 KB (21,776 bytes) 12/7/1999 6:00:00 AM
Microsoft Corporation c:\winnt\system32\perfos.dll
psapi.dll 5.00.2134.1 28.27 KB (28,944 bytes) 12/7/1999 6:00:00 AM
Microsoft Corporation c:\winnt\system32\psapi.dll
framedyn.dll 1.50.1085.0000 164.05 KB (167,992 bytes)
12/7/1999 6:00:00 AM Microsoft Corporation
c:\winnt\system32\wbem\framedyn.dll
cimwin32.dll 1.50.1085.0016 1.02 MB (1,073,232 bytes)
9/15/2000 3:20:23 PM Microsoft Corporation
c:\winnt\system32\wbem\cimwin32.dll
wbemsvc.dll 1.50.1085.0007 40.07 KB (41,036 bytes) 9/15/2000 3:20:23
PM Microsoft Corporation c:\winnt\system32\wbem\wbemsvc.dll
wbemess.dll 1.50.1085.0007 364.07 KB (372,804 bytes) 9/15/2000
3:20:23 PM Microsoft Corporation c:\winnt\system32\wbem\wbemess.dll
fastprox.dll 1.50.1085.0007 144.08 KB (147,536 bytes)
9/15/2000 3:20:23 PM Microsoft Corporation
c:\winnt\system32\wbem\fastprox.dll
wbemcore.dll 1.50.1085.0008 628.07 KB (643,140 bytes)
9/15/2000 3:20:23 PM Microsoft Corporation
c:\winnt\system32\wbem\wbemcore.dll
wbemcomn.dll 1.50.1085.0007 692.07 KB (708,675 bytes)
9/15/2000 3:20:23 PM Microsoft Corporation
c:\winnt\system32\wbem\wbemcomn.dll
winmgmt.exe 1.50.1085.0009 192.08 KB (196,685 bytes) 9/15/2000
3:20:22 PM Microsoft Corporation c:\winnt\system32\wbem\winmgmt.exe
ntmsdba.dll 5.00.2195.1600 167.77 KB (171,792 bytes) 9/15/2000
3:20:09 PM Microsoft Corporation c:\winnt\system32\ntmsdba.dll
rasdlg.dll 5.00.2194.1 514.27 KB (526,608 bytes) 12/7/1999 6:00:00
AM Microsoft Corporation c:\winnt\system32\rasdlg.dll
netcfgx.dll 5.00.2195.1618 533.77 KB (546,576 bytes) 9/15/2000
3:20:10 PM Microsoft Corporation c:\winnt\system32\netcfgx.dll
sens.dll 5.00.2163.1 36.77 KB (37,648 bytes) 12/7/1999 6:00:00 AM
Microsoft Corporation c:\winnt\system32\sens.dll
rasmans.dll 5.00.2195.27 146.77 KB (150,288 bytes) 9/15/2000
3:20:08 PM Microsoft Corporation c:\winnt\system32\rasmans.dll
wmi.dll 5.00.2191.1 6.27 KB (6,416 bytes) 12/7/1999 6:00:00 AM
Microsoft Corporation c:\winnt\system32\wmi.dll
netshell.dll 5.00.2195.1600 456.77 KB (467,728 bytes)
9/15/2000 3:20:10 PM Microsoft Corporation
c:\winnt\system32\netshell.dll
netman.dll 5.00.2195.1600 89.27 KB (91,408 bytes) 9/15/2000 3:20:10
PM Microsoft Corporation c:\winnt\system32\netman.dll
```

## Appendix C – Tunable Parameters

---

txfaux.dll	1999.9.3422.24	341.27 KB (349,456 bytes)	9/13/2000
6:15:49 AM	Microsoft Corporation	c:\winnt\system32\txfaux.dll	
es.dll	1999.9.3422.21	231.77 KB (237,328 bytes)	12/7/1999
6:00:00 AM	Microsoft Corporation	c:\winnt\system32\es.dll	
ntmssvc.dll	5.00.2187.1	390.77 KB (400,144 bytes)	12/7/1999 6:00:00
AM	Microsoft Corporation	c:\winnt\system32\ntmssvc.dll	
rasadhlp.dll	5.00.2168.1	7.27 KB (7,440 bytes)	12/7/1999 6:00:00
AM	Microsoft Corporation	c:\winnt\system32\rasadhlp.dll	
winrnr.dll	5.00.2160.1	18.77 KB (19,216 bytes)	12/7/1999 6:00:00 AM
	Microsoft Corporation	c:\winnt\system32\winrnr.dll	
rnr20.dll	5.00.2195.1207	35.77 KB (36,624 bytes)	9/15/2000 3:20:08
PM	Microsoft Corporation	c:\winnt\system32\rnr20.dll	
wshtcpip.dll	5.00.2134.1	17.27 KB (17,680 bytes)	12/7/1999 6:00:00
AM	Microsoft Corporation	c:\winnt\system32\wshtcpip.dll	
dhcpcsvc.dll	5.00.2153.1	88.77 KB (90,896 bytes)	12/7/1999 6:00:00
AM	Microsoft Corporation	c:\winnt\system32\dhcpcsvc.dll	
tapi32.dll	5.00.2182.1	123.27 KB (126,224 bytes)	12/7/1999 6:00:00
AM	Microsoft Corporation	c:\winnt\system32\tapi32.dll	
rasman.dll	5.00.2188.1	54.77 KB (56,080 bytes)	12/7/1999 6:00:00 AM
	Microsoft Corporation	c:\winnt\system32\rasman.dll	
rasapi32.dll	5.00.2188.1	189.77 KB (194,320 bytes)	12/7/1999
6:00:00 AM	Microsoft Corporation	c:\winnt\system32\rasapi32.dll	
iphlpapi.dll	5.00.2173.2	67.77 KB (69,392 bytes)	12/7/1999 6:00:00
AM	Microsoft Corporation	c:\winnt\system32\iphlpapi.dll	
msafd.dll	5.00.2195.1614	102.77 KB (105,232 bytes)	9/15/2000
3:20:13 PM	Microsoft Corporation	c:\winnt\system32\msafd.dll	
rpcss.dll	5.00.2195.1600	229.27 KB (234,768 bytes)	9/15/2000
3:20:08 PM	Microsoft Corporation	c:\winnt\system32\rpcss.dll	
svchost.exe	5.00.2134.1	7.77 KB (7,952 bytes)	12/7/1999 6:00:00 AM
	Microsoft Corporation	c:\winnt\system32\svchost.exe	
scecli.dll	5.00.2191.1	105.27 KB (107,792 bytes)	12/7/1999 6:00:00
AM	Microsoft Corporation	c:\winnt\system32\scecli.dll	
atl.dll	3.00.8449	57.56 KB (58,938 bytes)	12/7/1999 6:00:00 AM
	Microsoft Corporation	c:\winnt\system32\atl.dll	
certcli.dll	5.00.2175.1	132.27 KB (135,440 bytes)	12/7/1999 6:00:00
AM	Microsoft Corporation	c:\winnt\system32\certcli.dll	
mswsock.dll	5.00.2195.1207	62.77 KB (64,272 bytes)	9/15/2000 3:20:10
PM	Microsoft Corporation	c:\winnt\system32\mswsock.dll	
ntdsatq.dll	5.00.2195.1284	31.27 KB (32,016 bytes)	9/15/2000 3:20:09
PM	Microsoft Corporation	c:\winnt\system32\ntdsatq.dll	
ntdsa.dll	5.00.2195.1600	987.27 KB (1,010,960 bytes)	9/15/2000
3:20:09 PM	Microsoft Corporation	c:\winnt\system32\ntdsa.dll	
kdcsvc.dll	5.00.2195.1284	133.77 KB (136,976 bytes)	9/15/2000
3:20:13 PM	Microsoft Corporation	c:\winnt\system32\kdcsvc.dll	
sfmapi.dll	5.00.2134.1	38.77 KB (39,696 bytes)	12/7/1999 6:00:00 AM
	Microsoft Corporation	c:\winnt\system32\sfmapi.dll	
rtutils.dll	5.00.2168.1	43.77 KB (44,816 bytes)	12/7/1999 6:00:00 AM
	Microsoft Corporation	c:\winnt\system32\rtutils.dll	
activeds.dll	5.00.2172.1	172.77 KB (176,912 bytes)	12/7/1999
6:00:00 AM	Microsoft Corporation	c:\winnt\system32\activeds.dll	
mprapi.dll	5.00.2181.1	79.27 KB (81,168 bytes)	12/7/1999 6:00:00 AM
	Microsoft Corporation	c:\winnt\system32\mprapi.dll	
rassfm.dll	5.00.2195.1179	21.27 KB (21,776 bytes)	9/15/2000 3:20:08
PM	Microsoft Corporation	c:\winnt\system32\rassfm.dll	

## Appendix C – Tunable Parameters

---

mpr.dll 5.00.2195.1340 53.27 KB (54,544 bytes) 9/15/2000 3:20:13 PM Microsoft Corporation c:\winnt\system32\mpr.dll  
schannel.dll 5.00.2195.1163 137.27 KB (140,560 bytes) 7/21/2000 12:05:02 PM Microsoft Corporation c:\winnt\system32\schannel.dll  
netlogon.dll 5.00.2195.1600 348.27 KB (356,624 bytes) 9/15/2000 3:20:10 PM Microsoft Corporation c:\winnt\system32\netlogon.dll  
msv1\_0.dll 5.00.2195.1620 92.77 KB (94,992 bytes) 12/7/1999 6:00:00 AM Microsoft Corporation c:\winnt\system32\msv1\_0.dll  
kerberos.dll 5.00.2195.1378 197.77 KB (202,512 bytes) 9/15/2000 3:20:13 PM Microsoft Corporation c:\winnt\system32\kerberos.dll  
msprivs.dll 5.00.2154.1 41.50 KB (42,496 bytes) 12/7/1999 6:00:00 AM Microsoft Corporation c:\winnt\system32\msprivs.dll  
samsrv.dll 5.00.2195.1609 343.27 KB (351,504 bytes) 12/7/1999 6:00:00 AM Microsoft Corporation c:\winnt\system32\samsrv.dll  
lsasrv.dll 5.00.2195.1620 475.27 KB (486,672 bytes) 12/7/1999 6:00:00 AM Microsoft Corporation c:\winnt\system32\lsasrv.dll  
lsass.exe 5.00.2195.1620 32.77 KB (33,552 bytes) 12/7/1999 6:00:00 AM Microsoft Corporation c:\winnt\system32\lsass.exe  
esent.dll 6.0.3940.4 1.08 MB (1,135,888 bytes) 9/15/2000 3:20:15 PM Microsoft Corporation c:\winnt\system32\esent.dll  
msi.dll 1.11.1314.0 1.72 MB (1,798,928 bytes) 9/15/2000 3:20:12 PM Microsoft Corporation c:\winnt\system32\msi.dll  
adslrpc.dll 5.00.2195.1600 125.77 KB (128,784 bytes) 9/15/2000 3:20:18 PM Microsoft Corporation c:\winnt\system32\adslrpc.dll  
apppmgmts.dll 5.00.2168.1 117.77 KB (120,592 bytes) 12/7/1999 6:00:00 AM Microsoft Corporation c:\winnt\system32\apppmgmts.dll  
wmicore.dll 5.00.2178.1 70.77 KB (72,464 bytes) 12/7/1999 6:00:00 AM Microsoft Corporation c:\winnt\system32\wmicore.dll  
psbase.dll 5.00.2195.1600 111.77 KB (114,448 bytes) 9/15/2000 3:20:08 PM Microsoft Corporation c:\winnt\system32\psbase.dll  
cryptsvc.dll 5.00.2181.1 61.77 KB (63,248 bytes) 12/7/1999 6:00:00 AM Microsoft Corporation c:\winnt\system32\cryptsvc.dll  
cryptdll.dll 5.00.2135.1 41.27 KB (42,256 bytes) 12/7/1999 6:00:00 AM Microsoft Corporation c:\winnt\system32\cryptdll.dll  
wkssvc.dll 5.00.2195.1175 95.27 KB (97,552 bytes) 12/7/1999 6:00:00 AM Microsoft Corporation c:\winnt\system32\wkssvc.dll  
srvsvc.dll 5.00.2178.1 79.27 KB (81,168 bytes) 12/7/1999 6:00:00 AM Microsoft Corporation c:\winnt\system32\srvsvc.dll  
cfgmgr32.dll 5.00.2134.1 16.77 KB (17,168 bytes) 12/7/1999 6:00:00 AM Microsoft Corporation c:\winnt\system32\cfgmgr32.dll  
dmserver.dll 2195.23.297.2 11.77 KB (12,048 bytes) 9/15/2000 3:20:16 PM VERITAS Software Corp. c:\winnt\system32\dmserver.dll  
winsta.dll 5.00.2195.32 36.27 KB (37,136 bytes) 9/15/2000 3:20:06 PM Microsoft Corporation c:\winnt\system32\winsta.dll  
icmp.dll 5.00.2134.1 7.27 KB (7,440 bytes) 12/7/1999 6:00:00 AM Microsoft Corporation c:\winnt\system32\icmp.dll  
lmhsvc.dll 5.00.2134.1 9.27 KB (9,488 bytes) 12/7/1999 6:00:00 AM Microsoft Corporation c:\winnt\system32\lmhsvc.dll  
eventlog.dll 5.00.2178.1 43.77 KB (44,816 bytes) 12/7/1999 6:00:00 AM Microsoft Corporation c:\winnt\system32\eventlog.dll  
ntdsapi.dll 5.00.2160.1 56.27 KB (57,616 bytes) 12/7/1999 6:00:00 AM Microsoft Corporation c:\winnt\system32\ntdsapi.dll

## Appendix C – Tunable Parameters

---

scesrv.dll 5.00.2188.1 225.77 KB (231,184 bytes) 12/7/1999 6:00:00 AM Microsoft Corporation c:\winnt\system32\scesrv.dll  
umpnpgmgr.dll 5.00.2182.1 86.27 KB (88,336 bytes) 12/7/1999 6:00:00 AM Microsoft Corporation c:\winnt\system32\umpnpgmgr.dll  
services.exe 5.00.2134.1 86.77 KB (88,848 bytes) 12/7/1999 6:00:00 AM Microsoft Corporation c:\winnt\system32\services.exe  
clbcatq.dll 2000.2.3449.0 496.27 KB (508,176 bytes) 9/15/2000 3:20:17 PM Microsoft Corporation c:\winnt\system32\clbcatq.dll  
oleaut32.dll 2.40.4514 600.27 KB (614,672 bytes) 12/7/1999 6:00:00 AM Microsoft Corporation c:\winnt\system32\oleaut32.dll  
cscui.dll 5.00.2195.1387 227.27 KB (232,720 bytes) 9/15/2000 3:20:17 PM Microsoft Corporation c:\winnt\system32\cscui.dll  
winspool.drv 5.00.2195.1340 109.77 KB (112,400 bytes) 12/7/1999 6:00:00 AM Microsoft Corporation c:\winnt\system32\winspool.drv  
winscard.dll 5.00.2134.1 77.27 KB (79,120 bytes) 12/7/1999 6:00:00 AM Microsoft Corporation c:\winnt\system32\winscard.dll  
wlnotify.dll 5.00.2195.1163 53.27 KB (54,544 bytes) 9/15/2000 3:20:06 PM Microsoft Corporation c:\winnt\system32\wlnotify.dll  
cscdll.dll 5.00.2195.1600 98.27 KB (100,624 bytes) 9/15/2000 3:20:17 PM Microsoft Corporation c:\winnt\system32\cscdll.dll  
lz32.dll 5.00.2134.1 9.77 KB (10,000 bytes) 12/7/1999 6:00:00 AM Microsoft Corporation c:\winnt\system32\lz32.dll  
version.dll 5.00.2134.1 15.77 KB (16,144 bytes) 12/7/1999 6:00:00 AM Microsoft Corporation c:\winnt\system32\version.dll  
rsabase.dll 5.00.2195.1391 129.27 KB (132,368 bytes) 7/21/2000 12:05:02 PM Microsoft Corporation c:\winnt\system32\rsabase.dll  
mscat32.dll 5.131.2134.1 7.77 KB (7,952 bytes) 12/7/1999 6:00:00 AM Microsoft Corporation c:\winnt\system32\mscat32.dll  
ole32.dll 5.00.2195.1607 965.27 KB (988,432 bytes) 9/15/2000 3:20:09 PM Microsoft Corporation c:\winnt\system32\ole32.dll  
imagehlp.dll 5.00.2195.1 125.27 KB (128,272 bytes) 12/7/1999 6:00:00 AM Microsoft Corporation c:\winnt\system32\imagehlp.dll  
msasn1.dll 5.00.2134.1 51.27 KB (52,496 bytes) 12/7/1999 6:00:00 AM Microsoft Corporation c:\winnt\system32\msasn1.dll  
crypt32.dll 5.131.2195.1340 464.77 KB (475,920 bytes) 9/15/2000 3:20:17 PM Microsoft Corporation c:\winnt\system32\crypt32.dll  
wintrust.dll 5.131.2143.1 162.27 KB (166,160 bytes) 12/7/1999 6:00:00 AM Microsoft Corporation c:\winnt\system32\wintrust.dll  
setupapi.dll 5.00.2195.1608 552.77 KB (566,032 bytes) 12/7/1999 6:00:00 AM Microsoft Corporation c:\winnt\system32\setupapi.dll  
winmm.dll 5.00.2161.1 184.77 KB (189,200 bytes) 12/7/1999 6:00:00 AM Microsoft Corporation c:\winnt\system32\winmm.dll  
comctl32.dll 5.81 537.77 KB (550,672 bytes) 12/7/1999 6:00:00 AM Microsoft Corporation c:\winnt\system32\comctl32.dll  
shlwapi.dll 5.00.3103.1000 282.27 KB (289,040 bytes) 9/15/2000 3:20:07 PM Microsoft Corporation c:\winnt\system32\shlwapi.dll  
shell32.dll 5.00.3103.1000 2.25 MB (2,358,032 bytes) 9/15/2000 3:20:07 PM Microsoft Corporation c:\winnt\system32\shell32.dll  
msgina.dll 5.00.2195.1600 323.27 KB (331,024 bytes) 12/7/1999 6:00:00 AM Microsoft Corporation c:\winnt\system32\msgina.dll  
wsock32.dll 5.00.2195.1207 21.27 KB (21,776 bytes) 9/15/2000 3:20:06 PM Microsoft Corporation c:\winnt\system32\wsock32.dll

## Appendix C – Tunable Parameters

---

dnsapi.dll 5.00.2195.1600 127.77 KB (130,832 bytes) 9/15/2000  
3:20:16 PM Microsoft Corporation c:\winnt\system32\dnsapi.dll  
wldap32.dll 5.00.2195.1175 155.27 KB (158,992 bytes) 9/15/2000  
3:20:06 PM Microsoft Corporation c:\winnt\system32\wldap32.dll  
ws2help.dll 5.00.2134.1 17.77 KB (18,192 bytes) 12/7/1999 6:00:00 AM  
Microsoft Corporation c:\winnt\system32\ws2help.dll  
ws2\_32.dll 5.00.2195.1340 68.77 KB (70,416 bytes) 9/15/2000 3:20:06  
PM Microsoft Corporation c:\winnt\system32\ws2\_32.dll  
samlib.dll 5.00.2160.1 46.27 KB (47,376 bytes) 12/7/1999 6:00:00 AM  
Microsoft Corporation c:\winnt\system32\samlib.dll  
netrap.dll 5.00.2134.1 11.27 KB (11,536 bytes) 12/7/1999 6:00:00 AM  
Microsoft Corporation c:\winnt\system32\netrap.dll  
netapi32.dll 5.00.2195.1600 303.27 KB (310,544 bytes)  
9/15/2000 3:20:10 PM Microsoft Corporation  
c:\winnt\system32\netapi32.dll  
profmap.dll 5.00.2181.1 29.27 KB (29,968 bytes) 12/7/1999 6:00:00 AM  
Microsoft Corporation c:\winnt\system32\profmap.dll  
secur32.dll 5.00.2195.1600 47.27 KB (48,400 bytes) 9/15/2000 3:20:07  
PM Microsoft Corporation c:\winnt\system32\secur32.dll  
sfc.dll 5.00.2195.1618 90.05 KB (92,216 bytes) 9/15/2000 3:20:07  
PM Microsoft Corporation c:\winnt\system32\sfc.dll  
nddeapi.dll 5.00.2137.1 15.27 KB (15,632 bytes) 12/7/1999 6:00:00 AM  
Microsoft Corporation c:\winnt\system32\nddeapi.dll  
userenv.dll 5.00.2195.1600 359.27 KB (367,888 bytes) 12/7/1999  
6:00:00 AM Microsoft Corporation c:\winnt\system32\userenv.dll  
user32.dll 5.00.2195.1600 392.77 KB (402,192 bytes) 12/7/1999  
6:00:00 AM Microsoft Corporation c:\winnt\system32\user32.dll  
gdi32.dll 5.00.2195.1340 228.77 KB (234,256 bytes) 12/7/1999  
6:00:00 AM Microsoft Corporation c:\winnt\system32\gdi32.dll  
rpcrt4.dll 5.00.2195.1615 436.27 KB (446,736 bytes) 9/15/2000  
3:20:08 PM Microsoft Corporation c:\winnt\system32\rpcrt4.dll  
advapi32.dll 5.00.2195.1600 349.27 KB (357,648 bytes)  
12/7/1999 6:00:00 AM Microsoft Corporation  
c:\winnt\system32\advapi32.dll  
kernel32.dll 5.00.2195.1600 713.27 KB (730,384 bytes)  
12/7/1999 6:00:00 AM Microsoft Corporation  
c:\winnt\system32\kernel32.dll  
msvcrt.dll 6.10.8637.0 288.09 KB (295,000 bytes) 12/7/1999 6:00:00  
AM Microsoft Corporation c:\winnt\system32\msvcrt.dll  
winlogon.exe 5.00.2195.1600 172.77 KB (176,912 bytes)  
12/7/1999 6:00:00 AM Microsoft Corporation  
c:\winnt\system32\winlogon.exe  
sfcfiles.dll 5.00.2195.1 973.27 KB (996,624 bytes) 12/7/1999  
6:00:00 AM Microsoft Corporation c:\winnt\system32\sfcfiles.dll  
ntdll.dll 5.00.2195.1600 475.27 KB (486,672 bytes) 7/21/2000  
12:05:02 PM Microsoft Corporation c:\winnt\system32\ntdll.dll  
smss.exe 5.00.2195.31 44.27 KB (45,328 bytes) 12/7/1999 6:00:00  
AM Microsoft Corporation c:\winnt\system32\smss.exe

[Services]

Display Name	Name	State	Start	Mode	Service Type	Path	Error
Control	Start Name	Tag	ID				
Alerter	Alerter	Stopped		Manual	Share Process		
	c:\winnt\system32\services.exe				Normal	LocalSystem	0

## Appendix C – Tunable Parameters

---

Application Management	AppMgmt	Running	Manual	Share	
Process	c:\winnt\system32\services.exe		Normal	LocalSystem	0
Computer Browser	Browser	Stopped	Manual	Share	Process
	c:\winnt\system32\services.exe		Normal	LocalSystem	0
Indexing Service	cisvc	Stopped	Manual	Share	Process
	c:\winnt\system32\cisvc.exe		Normal	LocalSystem	0
ClipBook	ClipSrv	Stopped	Manual	Own	Process
	c:\winnt\system32\clipsrv.exe		Normal	LocalSystem	0
Distributed File System	Dfs	Stopped	Manual	Own	Process
	c:\winnt\system32\dfssvc.exe		Normal	LocalSystem	0
DHCP Client	Dhcp	Stopped	Manual	Share	Process
	c:\winnt\system32\services.exe		Normal	LocalSystem	0
Logical Disk Manager	Administrative	Service	dmadmin	Stopped	
	Manual	Share	Process	c:\winnt\system32\dmadmin.exe	/com
	Normal	LocalSystem			0
Logical Disk Manager	dmserver	Running	Auto	Share	Process
	c:\winnt\system32\services.exe		Normal	LocalSystem	0
DNS Client	Dnscache	Stopped	Manual	Share	Process
	c:\winnt\system32\services.exe		Normal	LocalSystem	0
Event Log	Eventlog	Running	Auto	Share	Process
	c:\winnt\system32\services.exe		Normal	LocalSystem	0
COM+ Event System	EventSystem	Stopped	Manual	Share	Process
	c:\winnt\system32\svchost.exe	-k netsvcs	Normal	LocalSystem	0
Fax Service	Fax	Stopped	Manual	Own	Process
	c:\winnt\system32\faxsvc.exe		Normal	LocalSystem	0
Mylex Global Array Manager	Server	gamscm	Stopped	Manual	
	Own Process	c:\winnt\system32\gamserv\gamscm.exe		Normal	LocalSystem
					0
cLAN Connection Manager	GniConMgr	Stopped	Disabled	Own	Process
	c:\winnt\system32\gnconmgr.exe		Normal	LocalSystem	0
Intersite Messaging	IsmServ	Stopped	Disabled	Own	Process
	c:\winnt\system32\ismserv.exe		Normal	LocalSystem	0
Kerberos Key Distribution Center	kdc	Stopped	Disabled	Share	
Process	c:\winnt\system32\lsass.exe		Normal	LocalSystem	0
Server	lanmanserver	Running	Auto	Share	Process
	c:\winnt\system32\services.exe		Normal	LocalSystem	0
Workstation	lanmanworkstation	Running	Auto	Share	Process
	c:\winnt\system32\services.exe		Normal	LocalSystem	0
License Logging Service	LicenseService	Stopped	Manual	Own	
Process	c:\winnt\system32\llssrv.exe		Normal	LocalSystem	0
TCP/IP NetBIOS Helper	Service LmHosts	Stopped	Auto	Share	
Process	c:\winnt\system32\services.exe		Normal	LocalSystem	0
Messenger	Messenger	Stopped	Manual	Share	Process
	c:\winnt\system32\services.exe		Normal	LocalSystem	0
NetMeeting Remote Desktop Sharing	mnmsrvc	Stopped	Manual		
	Own Process	c:\winnt\system32\mnmsrvc.exe		Normal	LocalSystem
					0
Distributed Transaction Coordinator	MSDTC	Stopped	Auto	Own	Process
	c:\winnt\system32\msdtc.exe		Normal	LocalSystem	0
Windows Installer	MSIServer	Stopped	Manual	Share	Process
	c:\winnt\system32\msiexec.exe	/v	Normal	LocalSystem	0

## Appendix C – Tunable Parameters

---

```

MSSQLSERVER MSSQLSERVER Stopped Manual Own Process
c:\progra~1\microso~2\mssql\bin\sqlservr.exe Normal
LocalSystem 0
MSSQLServerADHelper MSSQLServerADHelper Stopped Manual
Own Process c:\program files\microsoft sql
server\80\tools\bin\sqladhlp.exe Normal LocalSystem 0
Network DDE NetDDE Stopped Manual Share Process
c:\winnt\system32\netdde.exe Normal LocalSystem 0
Network DDE DSDM NetDDEdsdm Stopped Manual Share Process
c:\winnt\system32\netdde.exe Normal LocalSystem 0
Net Logon Netlogon Stopped Manual Share Process
c:\winnt\system32\lsass.exe Normal LocalSystem 0
Network Connections Netman Running Manual Share
Process c:\winnt\system32\svchost.exe -k netsvcs Normal
LocalSystem 0
File Replication NtFrs Stopped Manual Own Process
c:\winnt\system32\ntfrs.exe Ignore LocalSystem 0
NT LM Security Support Provider NtLmSsp Stopped Manual
Share Process c:\winnt\system32\lsass.exe Normal
LocalSystem 0
Removable Storage NtmsSvc Stopped Auto Share Process
c:\winnt\system32\svchost.exe -k netsvcs Normal LocalSystem
0
Plug and Play PlugPlay Running Auto Share Process
c:\winnt\system32\services.exe Normal LocalSystem 0
IPSEC Policy Agent PolicyAgent Stopped Manual Share
Process c:\winnt\system32\lsass.exe Normal LocalSystem 0
Protected Storage ProtectedStorage Running Auto Share Process
c:\winnt\system32\services.exe Normal LocalSystem 0
Remote Access Connection Manager RasAuto Stopped
Manual Share Process c:\winnt\system32\svchost.exe -k
netsvcs Normal LocalSystem 0
Remote Access Connection Manager RasMan Stopped Manual
Share Process c:\winnt\system32\svchost.exe -k netsvcs
Normal LocalSystem 0
Routing and Remote Access RemoteAccess Stopped Disabled
Share Process c:\winnt\system32\svchost.exe -k netsvcs
Normal LocalSystem 0
Remote Registry Service RemoteRegistry Stopped Manual Own
Process c:\winnt\system32\regsvc.exe Normal LocalSystem 0
Remote Procedure Call (RPC) Locator RpcLocator Stopped Manual
Own Process c:\winnt\system32\locator.exe Normal LocalSystem
0
Remote Procedure Call (RPC) RpcSs Running Auto Share Process
c:\winnt\system32\svchost -k rpcss Normal LocalSystem 0
QoS RSVP RSVP Running Manual Own Process
c:\winnt\system32\rsvp.exe -s Normal LocalSystem 0
Security Accounts Manager SamSs Running Auto Share Process
c:\winnt\system32\lsass.exe Normal LocalSystem 0
Smart Card Helper SCardDrv Stopped Manual Share Process
c:\winnt\system32\scardsvr.exe Ignore LocalSystem 0
Smart Card SCardSvr Stopped Manual Share Process
c:\winnt\system32\scardsvr.exe Ignore LocalSystem 0
Task Scheduler Schedule Stopped Manual Share Process
c:\winnt\system32\mstask.exe Normal LocalSystem 0

```

## Appendix C – Tunable Parameters

---

```

RunAs Service      seclogon      Stopped      Manual      Share Process
      c:\winnt\system32\services.exe      Ignore      LocalSystem 0
System Event Notification      SENS      Stopped      Manual      Share
Process      c:\winnt\system32\svchost.exe -k netsvcs      Normal
      LocalSystem 0
Internet Connection Sharing      SharedAccess      Stopped      Manual
      Share Process      c:\winnt\system32\svchost.exe -k netsvcs
      Normal      LocalSystem 0
Print Spooler      Spooler      Stopped      Manual      Own Process
      c:\winnt\system32\spoolsv.exe Normal      LocalSystem 0
SQLSERVERAGENT      SQLSERVERAGENT      Stopped      Manual      Own Process
      c:\progra~1\microso~2\mssql\bin\sqlagent.exe      Normal
      LocalSystem 0
Performance Logs and Alerts      SysmonLog      Stopped      Manual      Own
Process      c:\winnt\system32\smlogsvc.exe      Normal      LocalSystem
      0
Telephony      TapiSrv      Running      Manual      Share Process
      c:\winnt\system32\svchost.exe -k tapisrv      Normal      LocalSystem
      0
Terminal Services TermService      Stopped      Disabled      Own Process
      c:\winnt\system32\termsrv.exe Normal      LocalSystem 0
Telnet      TlntSvr      Stopped      Manual      Own Process
      c:\winnt\system32\tlntsvr.exe Normal      LocalSystem 0
Distributed Link Tracking Server      TrkSvr      Stopped      Manual
      Share Process      c:\winnt\system32\services.exe      Normal
      LocalSystem 0
Distributed Link Tracking Client      TrkWks      Stopped      Manual
      Share Process      c:\winnt\system32\services.exe      Normal
      LocalSystem 0
Uninterruptible Power Supply      UPS      Stopped      Manual      Own Process
      c:\winnt\system32\ups.exe      Normal      LocalSystem 0
Utility Manager      UtilMan      Stopped      Manual      Own Process
      c:\winnt\system32\utilman.exe Normal      LocalSystem 0
Windows Time      W32Time      Stopped      Manual      Share Process
      c:\winnt\system32\services.exe      Normal      LocalSystem 0
Windows Management Instrumentation      WinMgmt      Running      Auto Own
Process      c:\winnt\system32\wbem\winmgmt.exe      Ignore      LocalSystem
      0
Windows Management Instrumentation Driver Extensions      Wmi      Running
      Manual      Share Process      c:\winnt\system32\services.exe
      Normal      LocalSystem 0

```

### [Program Groups]

```

Group Name      Name      User Name
Accessories      Default User:Accessories      Default User
Accessories\Accessibility      Default User:Accessories\Accessibility
      Default User
Accessories\Entertainment      Default User:Accessories\Entertainment
      Default User
Accessories\System Tools      Default User:Accessories\System Tools
      Default User
Startup      Default User:Startup      Default User
Accessories All Users:Accessories      All Users

```

## Appendix C – Tunable Parameters

---

Accessories\Accessibility	All Users:Accessories\Accessibility	All Users
Accessories\Communications	All Users:Accessories\Communications	All Users
Accessories\Entertainment	All Users:Accessories\Entertainment	All Users
Accessories\Games	All Users:Accessories\Games	All Users
Accessories\System Tools	All Users:Accessories\System Tools	All Users
Administrative Tools	All Users:Administrative Tools	All Users
GigaNet	All Users:GigaNet	All Users
Microsoft SQL Server	All Users:Microsoft SQL Server	All Users
MKS Toolkit	All Users:MKS Toolkit	All Users
Startup	All Users:Startup	All Users
Accessories PE6400_01\Administrator:Accessories	PE6400_01\Administrator:Accessories	PE6400_01\Administrator
Accessories\Accessibility	PE6400_01\Administrator:Accessories\Accessibility	PE6400_01\Administrator
Accessories\Entertainment	PE6400_01\Administrator:Accessories\Entertainment	PE6400_01\Administrator
Accessories\System Tools	PE6400_01\Administrator:Accessories\System Tools	PE6400_01\Administrator
Administrative Tools	PE6400_01\Administrator:Administrative Tools	PE6400_01\Administrator
Startup	PE6400_01\Administrator:Startup	PE6400_01\Administrator

[Startup Programs]

Program	Command	User Name	Location
No startup program information			

[OLE Registration]

Object	Local Server
Sound (OLE2)	sndrec32.exe
Media Clip	mplay32.exe
Video Clip	mplay32.exe /avi
MIDI Sequence	mplay32.exe /mid
Sound	Not Available
Media Clip	Not Available
Image Document	"C:\Program Files\Windows NT\Accessories\ImageVue\KodakImg.exe"
WordPad Document	"%ProgramFiles%\Windows NT\Accessories\WORDPAD.EXE"
Windows Media Services DRM Storage object	Not Available
Bitmap Image	mspaint.exe

[Internet Explorer 5]

[ Following are sub-categories of this main category ]

[Summary]

Item	Value
------	-------

## Appendix C – Tunable Parameters

---

Version 5.00.3103.1000  
Build 53103.1000  
Product ID 51879-OEM-0000007-00000  
Application Path C:\Program Files\Internet Explorer

Language English (United States)  
Active Printer Not Available

Cipher Strength 56-bit  
Content Advisor Disabled  
IEAK Install No

### [File Versions]

File	Version	Size	Date	Path	Company
advapi32.dll	5.0.2195.1600	349 KB	7/21/2000 12:05:02 PM	C:\WINNT\system32	Microsoft Corporation
advapi32.dll	5.0.2195.1600	349 KB	7/21/2000 12:05:02 PM	.	Microsoft Corporation
advpack.dll	5.0.3103.1000	87 KB	7/21/2000 12:05:02 PM	C:\WINNT\system32	Microsoft Corporation
advpack.dll	5.0.3103.1000	87 KB	7/21/2000 12:05:02 PM	.	Microsoft Corporation
browseic.dll	5.0.3103.1000	35 KB	7/21/2000 12:05:02 PM	C:\WINNT\system32	Microsoft Corporation
browseic.dll	5.0.3103.1000	35 KB	7/21/2000 12:05:02 PM	.	Microsoft Corporation
browseui.dll	5.0.3103.1000	789 KB	7/21/2000 12:05:02 PM	C:\WINNT\system32	Microsoft Corporation
browseui.dll	5.0.3103.1000	789 KB	7/21/2000 12:05:02 PM	.	Microsoft Corporation
ckcnv.exe	5.0.2189.1	9 KB	12/7/1999 7:00:00 AM	C:\WINNT\system32	Microsoft Corporation
ckcnv.exe	5.0.2189.1	9 KB	12/7/1999 7:00:00 AM	.	Microsoft Corporation
comctl32.dll	5.81.3103.1000	538 KB	7/21/2000 12:05:02 PM	C:\WINNT\system32	Microsoft Corporation
comctl32.dll	5.81.3103.1000	538 KB	7/21/2000 12:05:02 PM	.	Microsoft Corporation
crypt32.dll	5.131.2195.1340	465 KB	7/21/2000 12:05:02 PM	C:\WINNT\system32	Microsoft Corporation
crypt32.dll	5.131.2195.1340	465 KB	7/21/2000 12:05:02 PM	.	Microsoft Corporation
enhsg.dll	<File Missing>	Not Available	Not Available	Not Available	Not Available
iemigrat.dll	<File Missing>	Not Available	Not Available	Not Available	Not Available
iesetup.dll	5.0.3103.1000	57 KB	7/21/2000 12:05:02 PM	C:\WINNT\system32	Microsoft Corporation
iesetup.dll	5.0.3103.1000	57 KB	7/21/2000 12:05:02 PM	.	Microsoft Corporation
iexplore.exe	5.0.2920.0	59 KB	12/7/1999 7:00:00 AM	C:\Program Files\Internet Explorer	Microsoft Corporation
imagehlp.dll	5.0.2195.1	125 KB	12/7/1999 7:00:00 AM	C:\WINNT\system32	Microsoft Corporation

## Appendix C – Tunable Parameters

---

imagehlp.dll	5.0.2195.1	125 KB	12/7/1999	7:00:00 AM	.
Microsoft Corporation					
imghelp.dll	<File Missing>	Not Available	Not Available	Not Available	Not Available
inseng.dll	5.0.3103.1000	72 KB	7/21/2000	12:05:02 PM	.
C:\WINNT\system32 Microsoft Corporation					
inseng.dll	5.0.3103.1000	72 KB	7/21/2000	12:05:02 PM	.
Microsoft Corporation					
jobexec.dll	5.0.0.1	47 KB	12/7/1999	7:00:00 AM	C:\WINNT\system32
Microsoft Corporation					
jobexec.dll	5.0.0.1	47 KB	12/7/1999	7:00:00 AM	. Microsoft Corporation
jscript.dll	5.1.0.5010	476 KB	7/21/2000	12:05:02 PM	.
C:\WINNT\system32 Microsoft Corporation					
jscript.dll	5.1.0.5010	476 KB	7/21/2000	12:05:02 PM	.
Microsoft Corporation					
jsproxy.dll	5.0.2920.0	13 KB	12/7/1999	7:00:00 AM	C:\WINNT\system32
Microsoft Corporation					
jsproxy.dll	5.0.2920.0	13 KB	12/7/1999	7:00:00 AM	. Microsoft Corporation
Microsoft Corporation					
mshahtml.dll	<File Missing>	Not Available	Not Available	Not Available	Not Available
Not Available Not Available					
mshhtml.dll	5.0.3103.1000	2292 KB	7/21/2000	12:05:02 PM	.
C:\WINNT\system32 Microsoft Corporation					
mshhtml.dll	5.0.3103.1000	2292 KB	7/21/2000	12:05:02 PM	.
Microsoft Corporation					
msjava.dll	5.0.3310.0	922 KB	7/21/2000	12:05:02 PM	.
C:\WINNT\system32 Microsoft Corporation					
msjava.dll	5.0.3310.0	922 KB	7/21/2000	12:05:02 PM	.
Microsoft Corporation					
msoss.dll	<File Missing>	Not Available	Not Available	Not Available	Not Available
Not Available Not Available					
msxml.dll	8.0.5226.0	506 KB	7/21/2000	12:05:02 PM	.
C:\WINNT\system32 Microsoft Corporation					
msxml.dll	8.0.5226.0	506 KB	7/21/2000	12:05:02 PM	.
Microsoft Corporation					
occache.dll	5.0.3103.1000	86 KB	7/21/2000	12:05:02 PM	.
C:\WINNT\system32 Microsoft Corporation					
occache.dll	5.0.3103.1000	86 KB	7/21/2000	12:05:02 PM	.
Microsoft Corporation					
ole32.dll	5.0.2195.1607	965 KB	7/21/2000	12:05:02 PM	.
C:\WINNT\system32 Microsoft Corporation					
ole32.dll	5.0.2195.1607	965 KB	7/21/2000	12:05:02 PM	.
Microsoft Corporation					
oleaut32.dll	2.40.4514.1	600 KB	7/21/2000	12:05:02 PM	.
C:\WINNT\system32 Microsoft Corporation					
oleaut32.dll	2.40.4514.1	600 KB	7/21/2000	12:05:02 PM	.
Microsoft Corporation					
olepro32.dll	5.0.4514.1	160 KB	7/21/2000	12:05:02 PM	.
C:\WINNT\system32 Microsoft Corporation					
olepro32.dll	5.0.4514.1	160 KB	7/21/2000	12:05:02 PM	.
Microsoft Corporation					
rsabase.dll	5.0.2195.1391	129 KB	7/21/2000	12:05:02 PM	.
C:\WINNT\system32 Microsoft Corporation					

## Appendix C – Tunable Parameters

---

```

rsabase.dll 5.0.2195.1391      129 KB      7/21/2000 12:05:02 PM .
    Microsoft Corporation
rsaenh.dll <File Missing>      Not Available      Not Available      Not
Available      Not Available
rsapi32.dll <File Missing>      Not Available      Not Available      Not
Available      Not Available
rsasig.dll <File Missing>      Not Available      Not Available      Not
Available      Not Available
schannel.dll 5.0.2195.0      137 KB      7/21/2000 12:05:02 PM
    C:\WINNT\system32 Microsoft Corporation
schannel.dll 5.0.2195.0      137 KB      7/21/2000 12:05:02 PM .
    Microsoft Corporation
shdoc401.dll <File Missing>      Not Available      Not Available
Not Available      Not Available
shdocvw.dll 5.0.3103.1000      1078 KB      7/21/2000 12:05:02 PM
    C:\WINNT\system32 Microsoft Corporation
shdocvw.dll 5.0.3103.1000      1078 KB      7/21/2000 12:05:02 PM .
    Microsoft Corporation
shell32.dll 5.0.3103.1000      2303 KB      7/21/2000 12:05:02 PM
    C:\WINNT\system32 Microsoft Corporation
shell32.dll 5.0.3103.1000      2303 KB      7/21/2000 12:05:02 PM .
    Microsoft Corporation
shlwapi.dll 5.0.3103.1000      282 KB      7/21/2000 12:05:02 PM
    C:\WINNT\system32 Microsoft Corporation
shlwapi.dll 5.0.3103.1000      282 KB      7/21/2000 12:05:02 PM .
    Microsoft Corporation
url.dll 5.0.2920.0      82 KB      12/7/1999 7:00:00 AM      C:\WINNT\system32
    Microsoft Corporation
url.dll 5.0.2920.0      82 KB      12/7/1999 7:00:00 AM      .      Microsoft
    Corporation
urlmon.dll 5.0.3103.1000      441 KB      7/21/2000 12:05:02 PM
    C:\WINNT\system32 Microsoft Corporation
urlmon.dll 5.0.3103.1000      441 KB      7/21/2000 12:05:02 PM .
    Microsoft Corporation
vbscript.dll 5.1.0.5010      428 KB      7/21/2000 12:05:02 PM
    C:\WINNT\system32 Microsoft Corporation
vbscript.dll 5.1.0.5010      428 KB      7/21/2000 12:05:02 PM .
    Microsoft Corporation
webcheck.dll 5.0.3103.1000      252 KB      7/21/2000 12:05:02 PM
    C:\WINNT\system32 Microsoft Corporation
webcheck.dll 5.0.3103.1000      252 KB      7/21/2000 12:05:02 PM
    .      Microsoft Corporation
win.com 5.0.2134.1      24 KB      12/7/1999 7:00:00 AM      C:\WINNT\system32
    Microsoft Corporation
win.com 5.0.2134.1      24 KB      12/7/1999 7:00:00 AM      .      Microsoft
    Corporation
wininet.dll 5.0.3103.1000      457 KB      7/21/2000 12:05:02 PM
    C:\WINNT\system32 Microsoft Corporation
wininet.dll 5.0.3103.1000      457 KB      7/21/2000 12:05:02 PM .
    Microsoft Corporation
winsock.dll 3.10.0.103      3 KB      12/7/1999 7:00:00 AM      C:\WINNT\system32
    Microsoft Corporation
winsock.dll 3.10.0.103      3 KB      12/7/1999 7:00:00 AM      .      Microsoft
    Corporation

```

## Appendix C – Tunable Parameters

---

wintrust.dll	5.131.2143.1	162 KB	12/7/1999 7:00:00 AM	
C:\WINNT\system32 Microsoft Corporation				
wintrust.dll	5.131.2143.1	162 KB	12/7/1999 7:00:00 AM	
. Microsoft Corporation				
wsock.vxd	<File Missing>	Not Available	Not Available	Not Available
Available Not Available				
wsock32.dll	5.0.2195.1207	21 KB	7/21/2000 12:05:02 PM	
C:\WINNT\system32 Microsoft Corporation				
wsock32.dll	5.0.2195.1207	21 KB	7/21/2000 12:05:02 PM	.
Microsoft Corporation				
wsock32n.dll	<File Missing>	Not Available	Not Available	Not Available
Not Available Not Available				

[Connectivity]

Item	Value
Connection Preference	Never dial
EnableHttp1.1	1
ProxyHttp1.1	0

LAN Settings

AutoConfigProxy	wininet.dll
AutoProxyDetectMode	Enabled
AutoConfigURL	
Proxy	Disabled
ProxyServer	
ProxyOverride	

[Cache]

[ Following are sub-categories of this main category ]

[Summary]

Item	Value
Page Refresh Type	Automatic
Temporary Internet Files Folder	C:\Documents and Settings\Administrator\Local Settings\Temporary Internet Files
Total Disk Space	8675 MB
Available Disk Space	4448 MB
Maximum Cache Size	270 MB
Available Cache Size	271 MB

[List of Objects]

Program File	Status	CodeBase
No cached object information available		

[Content]

[ Following are sub-categories of this main category ]

[Summary]

## Appendix C – Tunable Parameters

---

Item Value  
Content Advisor Disabled

[Personal Certificates]

Issued To	Issued By	Validity	Signature Algorithm
Administrator	Administrator	9/13/2000 to 8/20/2100	sha1RSA

[Other People Certificates]

Issued To	Issued By	Validity	Signature Algorithm
No other people certificate information available			

[Publishers]

Name  
No publisher information available

[Security]

Zone	Security Level
Local intranet	Medium-low
Trusted sites	Low
Internet	Medium
Restricted sites	High

# Appendix C – Tunable Parameters

---

## Client Configuration Parameters

### COM+ Settings

#### TPCC.AITxns:

##### Activation:

Enable Object Pooling selected  
Minimum Pool Size: 37  
Maximum Pool Size: 37  
Creation Timeout: 60,000  
Enable Object Construction  
Enable Just in Time Activation

##### Concurrency:

Concurrency Required

### TPCC Application Registry Parameters

```
[HKEY_LOCAL_MACHINE\SOFTWARE\Microsoft\TPCC]
"Path"="c:\inetpub\wwwroot\"
"NumberOfDeliveryThreads"=dword:00000004
"MaxConnections"=dword:00001b58
"MaxPendingDeliveries"=dword:000003e8
"DB_Protocol"="DBLIB"
"TxnMonitor"="COM"
"DbServer"="PE6400_01"
"DbName"="tpcc"
"DbUser"="sa"
"DbPassword"=""
"COM_SinglePool"="YES"
```

### Microsoft Internet Information Server Registry Parameters

Windows Registry Editor Version 5.00

```
[HKEY_LOCAL_MACHINE\SYSTEM\CurrentControlSet\Services\InetInfo]

[HKEY_LOCAL_MACHINE\SYSTEM\CurrentControlSet\Services\InetInfo\Parameters]
"ListenBackLog"=dword:00000019
"DispatchEntries"=hex(7):4c,00,44,00,41,00,50,00,53,00,56,00,43,00,00,00,00,00
"PoolThreadLimit"=dword:00000080
"ThreadTimeout"=dword:00015180
"BandwidthLevel"=dword:ffffffff
"DisableMemoryCache"=dword:00000001
"MemoryCacheSize"=dword:00000000
"ObjectCacheTTL"=dword:ffffffff

[HKEY_LOCAL_MACHINE\SYSTEM\CurrentControlSet\Services\InetInfo\Performance]
"Library"="infoctrs.dll"
"Open"="OpenINFOPerformanceData"
"Close"="CloseINFOPerformanceData"
"Collect"="CollectINFOPerformanceData"
"Last Counter"=dword:00000842
"Last Help"=dword:00000843
"First Counter"=dword:00000802
"First Help"=dword:00000803
"Library Validation Code"=hex:7e,3e,1e,80,75,1d,c0,01,10,25,00,00,00,00,00,00
```

## Appendix C – Tunable Parameters

---

```
"WbemAdapFileTime"=hex:00,33,eb,ce,35,f3,bf,01
"WbemAdapFileSize"=dword:00002510
"WbemAdapStatus"=dword:00000000
```

### World Wide Web Service Registry Parameters

Windows Registry Editor Version 5.00

```
[HKEY_LOCAL_MACHINE\SYSTEM\CurrentControlSet\Services\W3SVC]
```

```
"Type"=dword:00000020
```

```
"Start"=dword:00000002
```

```
"ErrorControl"=dword:00000001
```

```
"ImagePath"=hex(2):43,00,3a,00,5c,00,57,00,49,00,4e,00,4e,00,54,00,5c,00,53,00,\
79,00,73,00,74,00,65,00,6d,00,33,00,32,00,5c,00,69,00,6e,00,65,00,74,00,73,\
00,72,00,76,00,5c,00,69,00,6e,00,65,00,74,00,69,00,6e,00,66,00,6f,00,2e,00,\
65,00,78,00,65,00,00,00
```

```
"DisplayName"="World Wide Web Publishing Service"
```

```
"DependOnService"=hex(7):49,00,49,00,53,00,41,00,44,00,4d,00,49,00,4e,00,00,00,\
00,00
```

```
"DependOnGroup"=hex(7):00,00
```

```
"ObjectName"="LocalSystem"
```

```
"Description"="Provides Web connectivity and administration through the Internet Information Services snap-in."
```

```
[HKEY_LOCAL_MACHINE\SYSTEM\CurrentControlSet\Services\W3SVC\ASP]
```

```
"NOTE"="This is for backward compatibility only."
```

```
[HKEY_LOCAL_MACHINE\SYSTEM\CurrentControlSet\Services\W3SVC\ASP\Parameters]
```

```
[HKEY_LOCAL_MACHINE\SYSTEM\CurrentControlSet\Services\W3SVC\Parameters]
```

```
"MajorVersion"=dword:00000005
```

```
"MinorVersion"=dword:00000000
```

```
"InstallPath"="C:\\WINNT\\System32\\inetsrv"
```

```
"CertMapList"="C:\\WINNT\\System32\\inetsrv\\iisrmap.dll"
```

```
"AccessDeniedMessage"="Error: Access is Denied."
```

```
"Filter DLLs"=""
```

```
"LogFileDirectory"="C:\\WINNT\\System32\\LogFiles"
```

```
"AcceptExOutstanding"=dword:00000028
```

```
[HKEY_LOCAL_MACHINE\SYSTEM\CurrentControlSet\Services\W3SVC\Parameters\ADCLaunch]
```

```
[HKEY_LOCAL_MACHINE\SYSTEM\CurrentControlSet\Services\W3SVC\Parameters\ADCLaunch\AdvancedDataFactory]
```

```
[HKEY_LOCAL_MACHINE\SYSTEM\CurrentControlSet\Services\W3SVC\Parameters\ADCLaunch\RDSServer.DataFactory]
```

```
[HKEY_LOCAL_MACHINE\SYSTEM\CurrentControlSet\Services\W3SVC\Parameters\ScriptMap]
```

```
[HKEY_LOCAL_MACHINE\SYSTEM\CurrentControlSet\Services\W3SVC\Parameters\VirtualRoots]
```

## Appendix C – Tunable Parameters

---

"/"="c:\\inetpub\\wwwroot,,205"  
"/Scripts"="c:\\inetpub\\scripts,,204"  
"/IISHelp"="c:\\winnt\\help\\iishelp,,201"  
"/IISAdmin"="C:\\WINNT\\System32\\inetsrv\\iisadmin,,201"  
"/IISSamples"="c:\\inetpub\\iissamples,,201"  
"/MSADC"="c:\\program files\\common files\\system\\msadc,,205"  
"/\_vti\_bin"="C:\\Program Files\\Common Files\\Microsoft Shared\\Web Server  
Extensions\\40\\isapi,,205"  
"/Rpc"="C:\\WINNT\\System32\\RpcProxy,,4"  
"/Printers"="C:\\WINNT\\web\\printers,,201"

[HKEY\_LOCAL\_MACHINE\\SYSTEM\\CurrentControlSet\\Services\\W3SVC\\Performance]

"Library"="w3ctrs.dll"  
"Open"="OpenW3PerformanceData"  
"Close"="CloseW3PerformanceData"  
"Collect"="CollectW3PerformanceData"  
"Last Counter"=dword:000008e6  
"Last Help"=dword:000008e7  
"First Counter"=dword:00000844  
"First Help"=dword:00000845  
"Library Validation Code"=hex:a4,cc,16,83,75,1d,c0,01,10,3d,00,00,00,00,00,00  
"WbemAdapFileTime"=hex:00,33,eb,ce,35,f3,bf,01  
"WbemAdapFileSize"=dword:00003d10  
"WbemAdapStatus"=dword:00000000

[HKEY\_LOCAL\_MACHINE\\SYSTEM\\CurrentControlSet\\Services\\W3SVC\\Security]

"Security"=hex:01,00,14,80,a0,00,00,00,ac,00,00,00,14,00,00,00,30,00,00,00,02,\\  
00,1c,00,01,00,00,00,02,80,14,00,ff,01,0f,00,01,01,00,00,00,00,00,01,00,00,\\  
00,00,02,00,70,00,04,00,00,00,00,00,18,00,fd,01,02,00,01,01,00,00,00,00,00,\\  
05,12,00,00,00,74,00,6f,00,00,00,1c,00,ff,01,0f,00,01,02,00,00,00,00,00,05,\\  
20,00,00,00,20,02,00,00,72,00,73,00,00,00,18,00,8d,01,02,00,01,01,00,00,00,\\  
00,00,05,0b,00,00,00,20,02,00,00,00,00,1c,00,fd,01,02,00,01,02,00,00,00,00,\\  
00,05,20,00,00,00,23,02,00,00,72,00,73,00,01,01,00,00,00,00,00,05,12,00,00,\\  
00,01,01,00,00,00,00,00,05,12,00,00,00

[HKEY\_LOCAL\_MACHINE\\SYSTEM\\CurrentControlSet\\Services\\W3SVC\\Enum]

"0"="Root\\LEGACY\_W3SVC\\0000"  
"Count"=dword:00000001  
"NextInstance"=dword:00000001

## Appendix C – Tunable Parameters

---

### Microsoft Windows 2000 Server System Information Report for PE1300

System Information report written at: 10/15/2000 05:08:36 PM  
[System Information]

[ Following are sub-categories of this main category ]

[System Summary]

Item Value

OS Name Microsoft Windows 2000 Server  
Version 5.0.2195 Service Pack 1 Build 2195  
OS Manufacturer Microsoft Corporation  
System Name CLIENT2  
System Manufacturer Dell Computer Corporation  
System Model PowerEdge 1300/600  
System Type X86-based PC  
Processor x86 Family 6 Model 7 Stepping 3 GenuineIntel ~600 Mhz  
BIOS Version Phoenix ROM BIOS PLUS Version 1.10 A05  
Windows Directory C:\WINNT  
System Directory C:\WINNT\System32  
Boot Device \Device\Harddisk0\Partition1  
Locale United States  
User Name CLIENT2\Administrator  
Time Zone Central Daylight Time  
Total Physical Memory 523,824 KB  
Available Physical Memory 430,272 KB  
Total Virtual Memory 1,802,288 KB  
Available Virtual Memory 1,647,356 KB  
Page File Space 1,278,464 KB  
Page File C:\pagefile.sys

[Hardware Resources]

[ Following are sub-categories of this main category ]

[Conflicts/Sharing]

Resource Device  
No conflicted/shared resources

[DMA]

Channel	Device	Status
4	Direct memory access controller	OK
2	Standard floppy disk controller	OK

[Forced Hardware]

Device PNP Device ID  
No Forced Hardware

[I/O]

## Appendix C – Tunable Parameters

---

Address Range	Device	Status
0x0010-0x001F	PCI bus	OK
0x0022-0x003F	PCI bus	OK
0x0044-0x0047	PCI bus	OK
0x004C-0x006F	PCI bus	OK
0x0072-0x007F	PCI bus	OK
0x0090-0x0091	PCI bus	OK
0x0093-0x009F	PCI bus	OK
0x00A2-0x00BF	PCI bus	OK
0x00D0-0x00EF	PCI bus	OK
0x0100-0x0CF7	PCI bus	OK
0x0D00-0xFFFF	PCI bus	OK
0xE000-0xEFFF	Intel 82443BX Pentium(r) II Processor to AGP Controller	OK
0x03B0-0x03BB	Intel 82443BX Pentium(r) II Processor to AGP Controller	OK
0x03B0-0x03BB	ATI Technologies Inc. 3D RAGE IIC AGP	OK
0x03C0-0x03DF	Intel 82443BX Pentium(r) II Processor to AGP Controller	OK
0x03C0-0x03DF	ATI Technologies Inc. 3D RAGE IIC AGP	OK
0xEC00-0xEFFF	ATI Technologies Inc. 3D RAGE IIC AGP	OK
0xD000-0xDFFF	DEC 21152 PCI to PCI bridge	OK
0xDC00-0xDCFF	Adaptec AHA-2940U2/U2W PCI SCSI Controller	OK
0x0A79-0x0A79	ISAPNP Read Data Port	OK
0x0279-0x0279	ISAPNP Read Data Port	OK
0x0274-0x0277	ISAPNP Read Data Port	OK
0xFFA0-0xFFAF	Intel(r) 82371AB/EB PCI Bus Master IDE Controller	OK
0x0170-0x0177	Secondary IDE Channel	OK
0x0376-0x0376	Secondary IDE Channel	OK
0xCCE0-0xCFFF	Intel 82371AB/EB PCI to USB Universal Host Controller	OK
0xCCC0-0xCCDF	Intel(R) PRO/100+ PCI Adapter	OK
0xCCA0-0xCCBF	Intel(R) PRO/100+ PCI Adapter #3	OK
0x0020-0x003F	Programmable interrupt controller	OK
0x00A0-0x00BF	Programmable interrupt controller	OK
0x04D0-0x04D1	Programmable interrupt controller	OK
0x0040-0x005F	System timer	OK
0x0080-0x009F	Direct memory access controller	OK
0x0000-0x001F	Direct memory access controller	OK
0x00C0-0x00DF	Direct memory access controller	OK
0x0060-0x0060	PC/AT Enhanced PS/2 Keyboard (101/102-Key)	OK
0x0064-0x0064	PC/AT Enhanced PS/2 Keyboard (101/102-Key)	OK
0x0378-0x037F	ECP Printer Port (LPT1)	OK
0x0778-0x077B	ECP Printer Port (LPT1)	OK
0x03F8-0x03FF	Communications Port (COM1)	OK
0x02F8-0x02FF	Communications Port (COM2)	OK
0x03F0-0x03F5	Standard floppy disk controller	OK
0x03F7-0x03F7	Standard floppy disk controller	OK
0x0061-0x0061	System speaker	OK
0x0070-0x007F	System CMOS/real time clock	OK
0x0800-0x083F	System board	OK
0x0850-0x085F	System board	OK
0x0062-0x0063	System board	OK

## Appendix C – Tunable Parameters

---

0x0065-0x006F	System board	OK
0x00E0-0x00EF	System board	OK
0xAA00-0xAA7F	System board	OK
0x00F0-0x00FF	Numeric data processor	OK

### [IRQs]

IRQ Number	Device
44	Adaptec AHA-2940U2/U2W PCI SCSI Controller
15	Secondary IDE Channel
31	Intel 82371AB/EB PCI to USB Universal Host Controller
52	cLAN Host Adapter
56	Intel(R) PRO/100+ PCI Adapter
64	Intel(R) PRO/100+ PCI Adapter #3
1	PC/AT Enhanced PS/2 Keyboard (101/102-Key)
4	Communications Port (COM1)
3	Communications Port (COM2)
6	Standard floppy disk controller
8	System CMOS/real time clock
9	Motherboard resources
13	Numeric data processor
12	Microsoft PS/2 Mouse

### [Memory]

Range	Device	Status
0xA0000-0xBFFFF	PCI bus	OK
0xA0000-0xBFFFF	Intel 82443BX Pentium(r) II Processor to AGP Controller	OK
0xA0000-0xBFFFF	ATI Technologies Inc. 3D RAGE IIC AGP	OK
0xCD000-0xEFFFF	PCI bus	OK
0x20000000-0xFEBFFFFFF	PCI bus	OK
0xFEC10000-0xFEDFFFFFF	PCI bus	OK
0xFEE10000-0xFFFF7FFFF	PCI bus	OK
0xFB000000-0xFDFFFFFF	Intel 82443BX Pentium(r) II Processor to AGP Controller	OK
0xF2000000-0xF2FFFFFF	Intel 82443BX Pentium(r) II Processor to AGP Controller	OK
0xEC000000-0xEFFFFFFF	Intel 82443BX Pentium(r) II Processor to AGP Controller	OK
0xFC000000-0xFCFFFFFF	ATI Technologies Inc. 3D RAGE IIC AGP	OK
0xFBFFF000-0xFBFFFFFF	ATI Technologies Inc. 3D RAGE IIC AGP	OK
0xF9000000-0xFAFFFFFF	DEC 21152 PCI to PCI bridge	OK
0xF1000000-0xF1FFFFFF	DEC 21152 PCI to PCI bridge	OK
0xF9FFF000-0xF9FFFFFF	Adaptec AHA-2940U2/U2W PCI SCSI Controller	OK
0xFE400000-0xFE41FFFF	cLAN Host Adapter	OK
0xFE200000-0xFE3FFFFF	cLAN Host Adapter	OK
0xF7000000-0xF7FFFFFF	cLAN Host Adapter	OK
0xFE420000-0xFE42FFFF	cLAN Host Adapter	OK
0xF3001000-0xF3001FFF	Intel(R) PRO/100+ PCI Adapter	OK
0xFE100000-0xFE1FFFFFF	Intel(R) PRO/100+ PCI Adapter	OK
0xF3000000-0xF3000FFF	Intel(R) PRO/100+ PCI Adapter #3	OK
0xFE000000-0xFE0FFFFFF	Intel(R) PRO/100+ PCI Adapter #3	OK

## Appendix C – Tunable Parameters

---

0xFEE00000-0xFEE0FFFF Advanced programmable interrupt controller  
OK  
0xFEC00000-0xFEC0FFFF Advanced programmable interrupt controller  
OK  
0x0000-0x9FFFF System board OK  
0x100000-0x1FFFFDFFF System board OK  
0xFFE00000-0xFFFFFFFF System board OK  
0xF0000-0xFFFFF System board OK  
0xEC000-0xEFFFF System board OK

[Components]

[ Following are sub-categories of this main category ]

[Multimedia]

[ Following are sub-categories of this main category ]

[Audio Codecs]

Codec	Manufacturer	Description	Status	File	Version	Size
c:\winnt\system32\iac25_32.ax	Intel Corporation	Indeo® audio software	OK	C:\WINNT\System32\IAC25_32.AX	2.05.53	195.00 KB (199,680 bytes)
c:\winnt\system32\msg723.acm	Microsoft Corporation		OK	C:\WINNT\System32\MSG723.ACM	4.4.3385	106.77 KB (109,328 bytes)
c:\winnt\system32\lhacm.acm	Microsoft Corporation		OK	C:\WINNT\System32\LHACM.ACM	4.4.3385	33.27 KB (34,064 bytes)
c:\winnt\system32\tssoft32.acm	DSP GROUP, INC.		OK	C:\WINNT\System32\TSSOFT32.ACM	1.01	9.27 KB (9,488 bytes)
c:\winnt\system32\msg711.acm	Microsoft Corporation		OK	C:\WINNT\System32\MSG711.ACM	5.00.2134.1	10.27 KB (10,512 bytes)
c:\winnt\system32\msadp32.acm	Microsoft Corporation		OK	C:\WINNT\System32\MSADP32.ACM	5.00.2134.1	14.77 KB (15,120 bytes)
c:\winnt\system32\imaadp32.acm	Microsoft Corporation		OK	C:\WINNT\System32\IMAADP32.ACM	5.00.2134.1	16.27 KB (16,656 bytes)
c:\winnt\system32\msgsm32.acm	Microsoft Corporation		OK	C:\WINNT\System32\MSGSM32.ACM	5.00.2134.1	22.27 KB (22,800 bytes)

[Video Codecs]

Codec	Manufacturer	Description	Status	File	Version	Size
c:\winnt\system32\ir50_32.dll	Intel Corporation	Indeo® video	OK	C:\WINNT\System32\IR50_32.DLL	R.5.10.15.2.55	737.50 KB (755,200 bytes)

## Appendix C – Tunable Parameters

---

c:\winnt\system32\msh261.drv Microsoft Corporation OK  
C:\WINNT\System32\MSH261.DRV 4.4.3385 163.77 KB (167,696  
bytes) 9/13/2000 11:25:55 AM  
c:\winnt\system32\msh263.drv Microsoft Corporation OK  
C:\WINNT\System32\MSH263.DRV 4.4.3385 252.27 KB (258,320  
bytes) 9/13/2000 11:25:27 AM  
c:\winnt\system32\msvidc32.dll Microsoft Corporation OK  
C:\WINNT\System32\MSVIDC32.DLL 5.00.2134.1 27.27 KB (27,920  
bytes) 12/7/1999 6:00:00 AM  
c:\winnt\system32\msrle32.dll Microsoft Corporation OK  
C:\WINNT\System32\MSRLE32.DLL 5.00.2134.1 10.77 KB (11,024 bytes)  
12/7/1999 6:00:00 AM  
c:\winnt\system32\ir32\_32.dll Intel(R) Corporation OK  
C:\WINNT\System32\IR32\_32.DLL Not Available 194.50 KB  
(199,168 bytes) 12/7/1999 6:00:00 AM  
c:\winnt\system32\iccvid.dll Radius Inc. OK  
C:\WINNT\System32\ICCVID.DLL 1.10.0.6 108.00 KB (110,592  
bytes) 12/7/1999 6:00:00 AM

### [CD-ROM]

Item Value  
Drive D:  
Description CD-ROM Drive  
Media Loaded True  
Media Type CD-ROM  
Name SAMSUNG CD-ROM SC-140B  
Manufacturer (Standard CD-ROM drives)  
Status OK  
Transfer Rate 175.68 kbytes/sec  
SCSI Target ID 0  
PNP Device ID IDE\CDROMSAMSUNG\_CD-ROM\_SC-  
140B\_\_\_\_\_D005\_\_\_\_\4&13B4AFD&0&0.0.0

### [Sound Device]

Item Value  
No sound devices

### [Display]

Item Value  
Name ATI Technologies Inc. 3D RAGE IIC AGP  
PNP Device ID  
PCI\VEN\_1002&DEV\_4757&SUBSYS\_00000000&REV\_7A\3&225B1D41&0&0008  
Adapter Type ATI 3D RAGE IIC AGP (A21), ATI Technologies Inc.  
compatible  
Adapter Description ATI Technologies Inc. 3D RAGE IIC AGP  
Adapter RAM 2.00 MB (2,097,152 bytes)  
Installed Drivers atiraged.dll  
Driver Version 5.00.2174.1  
INF File display.inf (atirage section)  
Color Planes 1  
Color Table Entries 256

## Appendix C – Tunable Parameters

---

Resolution 1024 x 768 x 60 hertz  
Bits/Pixel 8

[Infrared]

Item Value  
No infrared devices

[Input]

[ Following are sub-categories of this main category ]

[Keyboard]

Item Value  
Description PC/AT Enhanced PS/2 Keyboard (101/102-Key)  
Name Enhanced (101- or 102-key)  
Layout 00000409  
PNP Device ID ROOT\\*PNP030B\1\_0\_22\_0\_32\_0  
NumberOfFunctionKeys 12

[Pointing Device]

Item Value  
Hardware Type Microsoft PS/2 Mouse  
Number of Buttons 2  
Status OK  
PNP Device ID ROOT\\*PNP0F03\1\_0\_21\_0\_31\_0  
Power Management Supported False  
Double Click Threshold 6  
Handedness Right Handed Operation

[Modem]

Item Value  
No modems

[Network]

[ Following are sub-categories of this main category ]

[Adapter]

Item Value  
Name [00000000] Intel(R) PRO/100+ PCI Adapter  
Adapter Type Ethernet 802.3  
Product Name Intel(R) PRO/100+ PCI Adapter  
Installed True  
PNP Device ID  
PCI\VEN\_8086&DEV\_1229&SUBSYS\_00098086&REV\_05\2&EBB567F&0&70  
Last Reset 10/13/2000 11:26:08 AM  
Index 0

## Appendix C – Tunable Parameters

---

Service Name E100B  
IP Address 192.1.20.100  
IP Subnet 255.255.255.0  
Default IP Gateway Not Available  
DHCP Enabled False  
DHCP Server Not Available  
DHCP Lease Expires Not Available  
DHCP Lease Obtained Not Available  
MAC Address 00:90:27:5C:D1:98  
Service Name E100B  
IRQ Number 56  
I/O Port 0xCCC0-0xCCDF  
Driver c:\winnt\system32\drivers\e100bnt5.sys (85776,  
4.02.38.0000)

Name [00000001] RAS Async Adapter  
Adapter Type Not Available  
Product Name RAS Async Adapter  
Installed True  
PNP Device ID Not Available  
Last Reset 10/13/2000 11:26:08 AM  
Index 1  
Service Name AsyncMac  
IP Address Not Available  
IP Subnet Not Available  
Default IP Gateway Not Available  
DHCP Enabled False  
DHCP Server Not Available  
DHCP Lease Expires Not Available  
DHCP Lease Obtained Not Available  
MAC Address Not Available  
Service Name Not Available

Name [00000002] WAN Miniport (L2TP)  
Adapter Type Not Available  
Product Name WAN Miniport (L2TP)  
Installed True  
PNP Device ID ROOT\MS\_L2TPMINIPORT\0000  
Last Reset 10/13/2000 11:26:08 AM  
Index 2  
Service Name Rasl2tp  
IP Address Not Available  
IP Subnet Not Available  
Default IP Gateway Not Available  
DHCP Enabled False  
DHCP Server Not Available  
DHCP Lease Expires Not Available  
DHCP Lease Obtained Not Available  
MAC Address Not Available  
Service Name Rasl2tp  
Driver c:\winnt\system32\drivers\rasl2tp.sys (50800, 5.00.2179.1)

Name [00000003] WAN Miniport (PPTP)  
Adapter Type Wide Area Network (WAN)  
Product Name WAN Miniport (PPTP)

## Appendix C – Tunable Parameters

---

Installed True  
PNP Device ID ROOT\MS\_PPTPMINIPOINT\0000  
Last Reset 10/13/2000 11:26:08 AM  
Index 3  
Service Name PptpMiniport  
IP Address Not Available  
IP Subnet Not Available  
Default IP Gateway Not Available  
DHCP Enabled False  
DHCP Server Not Available  
DHCP Lease Expires Not Available  
DHCP Lease Obtained Not Available  
MAC Address 50:50:54:50:30:30  
Service Name PptpMiniport  
Driver c:\winnt\system32\drivers\rasptp.sys (47856, 5.00.2160.1)

Name [00000004] Direct Parallel  
Adapter Type Not Available  
Product Name Direct Parallel  
Installed True  
PNP Device ID ROOT\MS\_PTIMINIPOINT\0000  
Last Reset 10/13/2000 11:26:08 AM  
Index 4  
Service Name Raspti  
IP Address Not Available  
IP Subnet Not Available  
Default IP Gateway Not Available

DHCP Enabled False  
DHCP Server Not Available  
DHCP Lease Expires Not Available  
DHCP Lease Obtained Not Available  
MAC Address Not Available  
Service Name Raspti  
Driver c:\winnt\system32\drivers\raspti.sys (16880, 5.00.2146.1)

Name [00000005] WAN Miniport (IP)  
Adapter Type Not Available  
Product Name WAN Miniport (IP)  
Installed True  
PNP Device ID ROOT\MS\_NDISWANIP\0000  
Last Reset 10/13/2000 11:26:08 AM  
Index 5  
Service Name NdisWan  
IP Address Not Available  
IP Subnet Not Available  
Default IP Gateway Not Available  
DHCP Enabled False  
DHCP Server Not Available  
DHCP Lease Expires Not Available  
DHCP Lease Obtained Not Available  
MAC Address Not Available  
Service Name NdisWan  
Driver c:\winnt\system32\drivers\ndiswan.sys (90768, 5.00.2184.1)

## Appendix C – Tunable Parameters

---

Name [00000006] cLAN Host Adapter  
Adapter Type Ethernet 802.3  
Product Name cLAN Host Adapter  
Installed True  
PNP Device ID  
PCI\VEN\_135B&DEV\_0001&SUBSYS\_00000000&REV\_00\2&EBB567F&0&68  
Last Reset 10/13/2000 11:26:08 AM  
Index 6  
Service Name GNINDIS  
IP Address  
IP Subnet  
Default IP Gateway Not Available  
DHCP Enabled True  
DHCP Server 255.255.255.255  
DHCP Lease Expires 1/18/2038 9:14:07 PM  
DHCP Lease Obtained 9/27/2000 8:03:01 PM  
MAC Address 00:90:FA:00:09:DA  
Service Name GNINDIS  
IRQ Number 52  
Driver c:\winnt\system32\drivers\gnindis.sys (22598, 4.1.1)

Name [00000007] Intel(R) PRO/100+ PCI Adapter  
Adapter Type Not Available  
Product Name Intel(R) PRO/100+ PCI Adapter  
Installed True  
PNP Device ID Not Available  
Last Reset 10/13/2000 11:26:08 AM  
Index 7  
Service Name E100B  
IP Address 192.1.20.100  
IP Subnet 255.255.255.0  
Default IP Gateway Not Available  
DHCP Enabled True  
DHCP Server  
DHCP Lease Expires Not Available  
DHCP Lease Obtained Not Available  
MAC Address 00:90:27:5C:D1:98  
Service Name Not Available

Name [00000008] Intel(R) PRO/100+ PCI Adapter  
Adapter Type Ethernet 802.3  
Product Name Intel(R) PRO/100+ PCI Adapter  
Installed True  
PNP Device ID  
PCI\VEN\_8086&DEV\_1229&SUBSYS\_00098086&REV\_05\2&EBB567F&0&80  
Last Reset 10/13/2000 11:26:08 AM  
Index 8  
Service Name E100B  
IP Address 192.1.1.2  
IP Subnet 255.255.255.0  
Default IP Gateway Not Available  
DHCP Enabled False  
DHCP Server Not Available  
DHCP Lease Expires Not Available  
DHCP Lease Obtained Not Available

## Appendix C – Tunable Parameters

---

MAC Address 00:90:27:5C:D1:D4  
Service Name E100B  
IRQ Number 64  
I/O Port 0xCCA0-0xCCBF  
Driver c:\winnt\system32\drivers\e100bnt5.sys (85776,  
4.02.38.0000)

[Protocol]

Item Value  
Name MSAFD Tcpip [TCP/IP]  
ConnectionlessService False  
GuaranteesDelivery True  
GuaranteesSequencing True  
MaximumAddressSize 16 bytes  
MaximumMessageSize 0 bytes  
MessageOriented False  
MinimumAddressSize 16 bytes  
PseudoStreamOriented False  
SupportsBroadcasting False  
SupportsConnectData False  
SupportsDisconnectData False  
SupportsEncryption False  
SupportsExpeditedData True  
SupportsGracefulClosing True  
SupportsGuaranteedBandwidth False  
SupportsMulticasting False

Name MSAFD Tcpip [UDP/IP]  
ConnectionlessService True  
GuaranteesDelivery False  
GuaranteesSequencing False  
MaximumAddressSize 16 bytes  
MaximumMessageSize 65467 bytes  
MessageOriented True  
MinimumAddressSize 16 bytes  
PseudoStreamOriented False  
SupportsBroadcasting True  
SupportsConnectData False  
SupportsDisconnectData False  
SupportsEncryption False  
SupportsExpeditedData False  
SupportsGracefulClosing False  
SupportsGuaranteedBandwidth False  
SupportsMulticasting True

Name RSVP UDP Service Provider  
ConnectionlessService True  
GuaranteesDelivery False  
GuaranteesSequencing False  
MaximumAddressSize 16 bytes  
MaximumMessageSize 65467 bytes  
MessageOriented True  
MinimumAddressSize 16 bytes

## Appendix C – Tunable Parameters

---

PseudoStreamOriented      False  
SupportsBroadcasting      True  
SupportsConnectData      False  
SupportsDisconnectData    False  
SupportsEncryption      True  
SupportsExpeditedData      False  
SupportsGracefulClosing    False  
SupportsGuaranteedBandwidth   False  
SupportsMulticasting      True

Name    RSVP TCP Service Provider  
ConnectionlessService    False  
GuaranteesDelivery      True  
GuaranteesSequencing    True  
MaximumAddressSize      16 bytes  
MaximumMessageSize      0 bytes  
MessageOriented      False  
MinimumAddressSize      16 bytes  
PseudoStreamOriented    False  
SupportsBroadcasting    False  
SupportsConnectData      False  
SupportsDisconnectData    False  
SupportsEncryption      True  
SupportsExpeditedData    True  
SupportsGracefulClosing   True  
SupportsGuaranteedBandwidth   False  
SupportsMulticasting      False

Name    MSAFD NetBIOS [\Device\NetBT\_Tcpip\_{6449A978-B49A-4713-AD9B-E83FD85CB133}] SEQPACKET 5  
ConnectionlessService    False  
GuaranteesDelivery      True  
GuaranteesSequencing    True  
MaximumAddressSize      20 bytes  
MaximumMessageSize      64000 bytes  
MessageOriented      True  
MinimumAddressSize      20 bytes  
PseudoStreamOriented    False  
SupportsBroadcasting    False  
SupportsConnectData      False  
SupportsDisconnectData    False  
SupportsEncryption      False  
SupportsExpeditedData    False  
SupportsGracefulClosing   False  
SupportsGuaranteedBandwidth   False  
SupportsMulticasting      False

Name    MSAFD NetBIOS [\Device\NetBT\_Tcpip\_{6449A978-B49A-4713-AD9B-E83FD85CB133}] DATAGRAM 5  
ConnectionlessService    True  
GuaranteesDelivery      False  
GuaranteesSequencing    False  
MaximumAddressSize      20 bytes  
MaximumMessageSize      64000 bytes  
MessageOriented      True

## Appendix C – Tunable Parameters

---

MinimumAddressSize 20 bytes  
PseudoStreamOriented False  
SupportsBroadcasting True  
SupportsConnectData False  
SupportsDisconnectData False  
SupportsEncryption False  
SupportsExpeditedData False  
SupportsGracefulClosing False  
SupportsGuaranteedBandwidth False  
SupportsMulticasting False

Name MSAFD NetBIOS [\Device\NetBT\_Tcpip\_{8BA4A65D-EC53-4A85-B4C2-02DDD4F7687E}] SEQPACKET 4

ConnectionlessService False  
GuaranteesDelivery True  
GuaranteesSequencing True  
MaximumAddressSize 20 bytes  
MaximumMessageSize 64000 bytes  
MessageOriented True  
MinimumAddressSize 20 bytes  
PseudoStreamOriented False  
SupportsBroadcasting False  
SupportsConnectData False  
SupportsDisconnectData False  
SupportsEncryption False  
SupportsExpeditedData False  
SupportsGracefulClosing False  
SupportsGuaranteedBandwidth False  
SupportsMulticasting False

Name MSAFD NetBIOS [\Device\NetBT\_Tcpip\_{8BA4A65D-EC53-4A85-B4C2-02DDD4F7687E}] DATAGRAM 4

ConnectionlessService True  
GuaranteesDelivery False  
GuaranteesSequencing False  
MaximumAddressSize 20 bytes  
MaximumMessageSize 64000 bytes  
MessageOriented True  
MinimumAddressSize 20 bytes  
PseudoStreamOriented False  
SupportsBroadcasting True  
SupportsConnectData False  
SupportsDisconnectData False  
SupportsEncryption False  
SupportsExpeditedData False  
SupportsGracefulClosing False  
SupportsGuaranteedBandwidth False  
SupportsMulticasting False

Name MSAFD NetBIOS [\Device\NetBT\_Tcpip\_{186A986F-C466-4BC3-AAF2-19EFE8C0B2B8}] SEQPACKET 3

ConnectionlessService False  
GuaranteesDelivery True  
GuaranteesSequencing True  
MaximumAddressSize 20 bytes

## Appendix C – Tunable Parameters

---

MaximumMessageSize 64000 bytes  
MessageOriented True  
MinimumAddressSize 20 bytes  
PseudoStreamOriented False  
SupportsBroadcasting False  
SupportsConnectData False  
SupportsDisconnectData False  
SupportsEncryption False  
SupportsExpeditedData False  
SupportsGracefulClosing False  
SupportsGuaranteedBandwidth False  
SupportsMulticasting False

Name MSAFD NetBIOS [\Device\NetBT\_Tcpip\_{186A986F-C466-4BC3-AAF2-19EFE8C0B2B8}] DATAGRAM 3

ConnectionlessService True  
GuaranteesDelivery False  
GuaranteesSequencing False  
MaximumAddressSize 20 bytes  
MaximumMessageSize 64000 bytes  
MessageOriented True  
MinimumAddressSize 20 bytes  
PseudoStreamOriented False  
SupportsBroadcasting True  
SupportsConnectData False  
SupportsDisconnectData False  
SupportsEncryption False  
SupportsExpeditedData False  
SupportsGracefulClosing False  
SupportsGuaranteedBandwidth False  
SupportsMulticasting False

Name MSAFD NetBIOS [\Device\NetBT\_Tcpip\_{39F73F3C-0803-4A82-8158-B8DDBC4C30E4}] SEQPACKET 0

ConnectionlessService False  
GuaranteesDelivery True  
GuaranteesSequencing True  
MaximumAddressSize 20 bytes  
MaximumMessageSize 64000 bytes  
MessageOriented True  
MinimumAddressSize 20 bytes  
PseudoStreamOriented False  
SupportsBroadcasting False  
SupportsConnectData False  
SupportsDisconnectData False  
SupportsEncryption False  
SupportsExpeditedData False  
SupportsGracefulClosing False  
SupportsGuaranteedBandwidth False  
SupportsMulticasting False

Name MSAFD NetBIOS [\Device\NetBT\_Tcpip\_{39F73F3C-0803-4A82-8158-B8DDBC4C30E4}] DATAGRAM 0

ConnectionlessService True  
GuaranteesDelivery False

## Appendix C – Tunable Parameters

---

GuaranteesSequencing False  
MaximumAddressSize 20 bytes  
MaximumMessageSize 64000 bytes  
MessageOriented True  
MinimumAddressSize 20 bytes  
PseudoStreamOriented False  
SupportsBroadcasting True  
SupportsConnectData False  
SupportsDisconnectData False  
SupportsEncryption False  
SupportsExpeditedData False  
SupportsGracefulClosing False  
SupportsGuaranteedBandwidth False  
SupportsMulticasting False

Name MSAFD NetBIOS [\Device\NetBT\_Tcpip\_{D13BBD8A-6510-4ED2-877D-E3BFE3CC0ED0}] SEQPACKET 1

ConnectionlessService False  
GuaranteesDelivery True  
GuaranteesSequencing True  
MaximumAddressSize 20 bytes  
MaximumMessageSize 64000 bytes  
MessageOriented True  
MinimumAddressSize 20 bytes  
PseudoStreamOriented False  
SupportsBroadcasting False  
SupportsConnectData False  
SupportsDisconnectData False  
SupportsEncryption False  
SupportsExpeditedData False  
SupportsGracefulClosing False  
SupportsGuaranteedBandwidth False  
SupportsMulticasting False

Name MSAFD NetBIOS [\Device\NetBT\_Tcpip\_{D13BBD8A-6510-4ED2-877D-E3BFE3CC0ED0}] DATAGRAM 1

ConnectionlessService True  
GuaranteesDelivery False  
GuaranteesSequencing False  
MaximumAddressSize 20 bytes  
MaximumMessageSize 64000 bytes  
MessageOriented True  
MinimumAddressSize 20 bytes  
PseudoStreamOriented False  
SupportsBroadcasting True  
SupportsConnectData False  
SupportsDisconnectData False  
SupportsEncryption False  
SupportsExpeditedData False  
SupportsGracefulClosing False  
SupportsGuaranteedBandwidth False  
SupportsMulticasting False

Name MSAFD NetBIOS [\Device\NetBT\_Tcpip\_{51C52CA2-22FC-4D77-B326-50B3C60B96A3}] SEQPACKET 2

## Appendix C – Tunable Parameters

---

ConnectionlessService False  
GuaranteesDelivery True  
GuaranteesSequencing True  
MaximumAddressSize 20 bytes  
MaximumMessageSize 64000 bytes  
MessageOriented True  
MinimumAddressSize 20 bytes  
PseudoStreamOriented False  
SupportsBroadcasting False  
SupportsConnectData False  
SupportsDisconnectData False  
SupportsEncryption False  
SupportsExpeditedData False  
SupportsGracefulClosing False  
SupportsGuaranteedBandwidth False  
SupportsMulticasting False

Name MSAFD NetBIOS [\\Device\NetBT\_Tcpip\_{51C52CA2-22FC-4D77-B326-50B3C60B96A3}] DATAGRAM 2

ConnectionlessService True  
GuaranteesDelivery False  
GuaranteesSequencing False  
MaximumAddressSize 20 bytes  
MaximumMessageSize 64000 bytes  
MessageOriented True  
MinimumAddressSize 20 bytes  
PseudoStreamOriented False  
SupportsBroadcasting True  
SupportsConnectData False  
SupportsDisconnectData False  
SupportsEncryption False  
SupportsExpeditedData False  
SupportsGracefulClosing False  
SupportsGuaranteedBandwidth False  
SupportsMulticasting False

### [WinSock]

Item Value  
File c:\winnt\system32\winsock.dll  
Version 3.10  
Size 2.80 KB (2,864 bytes)

File c:\winnt\system32\wsock32.dll  
Version 5.00.2195.1207  
Size 21.27 KB (21,776 bytes)

### [Ports]

[ Following are sub-categories of this main category ]

### [Serial]

## Appendix C – Tunable Parameters

---

Item Value  
Name COM1  
Status OK  
PNP Device ID ROOT\\*PNP0501\PNPBIOS\_1  
Maximum Input Buffer Size Not Available  
Maximum Output Buffer Size Not Available  
Settable Baud Rate Not Available  
Settable Data Bits Not Available  
Settable Flow Control Not Available  
Settable Parity Not Available  
Settable Parity Check Not Available  
Settable Stop Bits Not Available  
Settable RLSD Not Available  
Supports RLSD Not Available  
Supports 16 Bit Mode Not Available  
Supports Special Characters Not Available  
Baud Rate 9600  
Bits/Byte 8  
Stop Bits 1  
Parity None  
Busy -1  
Abort Read/Write on Error Not Available  
Binary Mode Enabled Not Available  
Continue XMit on XOff Not Available  
CTS Outflow Control Not Available  
Discard NULL Bytes Not Available  
DSR Outflow Control Not Available  
DSR Sensitivity Not Available  
DTR Flow Control Type Not Available  
EOF Character Not Available  
Error Replace Character Not Available  
Error Replacement Enabled Not Available  
Event Character Not Available  
Parity Check Enabled -1  
RTS Flow Control Type Not Available  
XOff Character 19  
XOffXMit Threshold 512  
XOn Character 17  
XOnXMit Threshold 2048  
XOnXOff InFlow Control Not Available  
XOnXOff OutFlow Control Not Available  
IRQ Number 4  
I/O Port 0x03F8-0x03FF  
Driver c:\winnt\system32\drivers\serial.sys (62448, 5.00.2134.1)

Name COM2  
Status OK  
PNP Device ID ROOT\\*PNP0501\PNPBIOS\_2  
Maximum Input Buffer Size 0  
Maximum Output Buffer Size False  
Settable Baud Rate True  
Settable Data Bits True  
Settable Flow Control True  
Settable Parity True  
Settable Parity Check True

## Appendix C – Tunable Parameters

---

Settable Stop Bits True  
Settable RLSD True  
Supports RLSD True  
Supports 16 Bit Mode False  
Supports Special Characters False  
Baud Rate 9600  
Bits/Byte 8  
Stop Bits 1  
Parity None  
Busy 0  
Abort Read/Write on Error 0  
Binary Mode Enabled -1  
Continue XMit on XOff 0  
CTS Outflow Control 0  
Discard NULL Bytes 0  
DSR Outflow Control 0  
DSR Sensitivity 0  
DTR Flow Control Type Enable  
EOF Character 0  
Error Replace Character 0  
Error Replacement Enabled 0  
Event Character 0  
Parity Check Enabled 0  
RTS Flow Control Type Enable  
XOff Character 19  
XOffXMit Threshold 512  
XOn Character 17  
XOnXMit Threshold 2048  
XOnXOff InFlow Control 0  
XOnXOff OutFlow Control 0  
IRQ Number 3  
I/O Port 0x02F8-0x02FF  
Driver c:\winnt\system32\drivers\serial.sys (62448, 5.00.2134.1)

[Parallel]

Item Value  
Name LPT1  
PNP Device ID ROOT\\*PNP0401\PNPBIOS\_3

[Storage]

[ Following are sub-categories of this main category ]

[Drives]

Item Value  
Drive A:  
Description 3 1/2 Inch Floppy Drive

Drive C:  
Description Local Fixed Disk  
Compressed False

## Appendix C – Tunable Parameters

---

File System NTFS  
Size 4.24 GB (4,556,771,328 bytes)  
Free Space 1.44 GB (1,543,471,104 bytes)  
Volume Name  
Volume Serial Number A03ABF83  
Partition Disk #0, Partition #0  
Partition Size 4.24 GB (4,556,772,864 bytes)  
Starting Offset 32256 bytes  
Drive Description Disk drive  
Drive Manufacturer (Standard disk drives)  
Drive Model QUANTUM VIKING II 4.5WLS SCSI Disk Device  
Drive BytesPerSector 512  
Drive MediaLoaded True  
Drive MediaType Fixed hard disk media  
Drive Partitions 1  
Drive SCSIbus 0  
Drive SCSILogicalUnit 0  
Drive SCSIPort 1  
Drive SCSTargetId 1  
Drive SectorsPerTrack 63  
Drive Size 4556805120 bytes  
Drive TotalCylinders 554  
Drive TotalSectors 8900010  
Drive TotalTracks 141270  
Drive TracksPerCylinder 255

[SCSI]

Item Value  
Name Adaptec AHA-2940U2/U2W PCI SCSI Controller  
Caption Adaptec AHA-2940U2/U2W PCI SCSI Controller  
Driver aic78u2  
Status OK  
PNP Device ID  
PCI\VEN\_9005&DEV\_001F&SUBSYS\_000F9005&REV\_01\3&3034C9FE&0&5810  
Device ID  
PCI\VEN\_9005&DEV\_001F&SUBSYS\_000F9005&REV\_01\3&3034C9FE&0&5810  
Device Map Not Available  
Index Not Available  
Max Number Controlled Not Available  
IRQ Number 44  
I/O Port 0xDC00-0xDCFF  
Driver c:\winnt\system32\drivers\aic78u2.sys (65168, v3.00a)

[Printing]

Name Port Name Server Name  
No printing information

[Problem Devices]

Device	PNP Device ID	Error Code
No Problem Devices		

## Appendix C – Tunable Parameters

---

[USB]

Device PNP Device ID  
Intel 82371AB/EB PCI to USB Universal Host Controller  
PCI\VEN\_8086&DEV\_7112&SUBSYS\_00000000&REV\_01\2&EBB567F&0&3A  
USB Root Hub USB\ROOT\_HUB\3&32C8BD93&0

[Software Environment]

[ Following are sub-categories of this main category ]

[Drivers]

Name	Description	File	Type	Started	Start Mode	State	Status		
	Error Control		Accept	Pause	Accept	Stop			
abiosdsk	Abiosdsk	Not Available	Kernel Driver	False	False	False	False		
	Disabled	Stopped	OK	Ignore	False	False	False		
abp480n5	abp480n5	Not Available	Kernel Driver	False	False	False	False		
	Disabled	Stopped	OK	Normal	False	False	False		
acpi	ACPI	Not Available	Kernel Driver	False	False	Disabled	False		
	Stopped	OK	Normal	False	False	False	False		
acpiec	ACPIEC	Not Available	Kernel Driver	False	False	False	False		
	Disabled	Stopped	OK	Normal	False	False	False		
adpu160m	adpu160m	Not Available	Kernel Driver	False	False	False	False		
	Disabled	Stopped	OK	Normal	False	False	False		
afd	AFD Networking Support Environment								
	c:\winnt\system32\drivers\afd.sys	Kernel Driver	True	Auto					
	Running	OK	Normal	False	True				
agp440	Intel AGP Bus Filter								
	c:\winnt\system32\drivers\agp440.sys	Kernel Driver	True						
	Boot	Running	OK	Normal	False	True			
aha154x	Aha154x	Not Available	Kernel Driver	False	False	False	False		
	Disabled	Stopped	OK	Normal	False	False	False		
aic116x	aic116x	Not Available	Kernel Driver	False	False	False	False		
	Disabled	Stopped	OK	Normal	False	False	False		
aic78u2	aic78u2	c:\winnt\system32\drivers\aic78u2.sys	Kernel Driver	True	Boot	Running	OK	Normal	False
	True								
aic78xx	aic78xx	Not Available	Kernel Driver	False	False	False	False	False	False
	Disabled	Stopped	OK	Normal	False	False	False	False	False
ami0nt	ami0nt	Not Available	Kernel Driver	False	False	False	False	False	False
	Disabled	Stopped	OK	Normal	False	False	False	False	False
amsint	amsint	Not Available	Kernel Driver	False	False	False	False	False	False
	Disabled	Stopped	OK	Normal	False	False	False	False	False
asc	asc	Not Available	Kernel Driver	False	False	Disabled	False	False	False
	Stopped	OK	Normal	False	False	False	False	False	False
asc3350p	asc3350p	Not Available	Kernel Driver	False	False	False	False	False	False
	Disabled	Stopped	OK	Normal	False	False	False	False	False
asc3550	asc3550	Not Available	Kernel Driver	False	False	False	False	False	False
	Disabled	Stopped	OK	Normal	False	False	False	False	False
asyncmac	RAS Asynchronous Media Driver								
	c:\winnt\system32\drivers\asyncmac.sys	Kernel Driver	False						
	Manual	Stopped	OK	Normal	False	False	False	False	False

## Appendix C – Tunable Parameters

---

```

atapi Standard IDE/ESDI Hard Disk Controller
      c:\winnt\system32\drivers\atapi.sys Kernel Driver      True  Boot
      Running      OK      Normal      False True
atdisk      Atdisk      Not Available      Kernel Driver      False
      Disabled      Stopped      OK      Ignore      False False
atirage      atirage      c:\winnt\system32\drivers\atiragem.sys
      Kernel Driver      True Manual      Running      OK      Ignore
      False True
atmarpc      ATM ARP Client Protocol
      c:\winnt\system32\drivers\atmarpc.sys      Kernel Driver      False
      Manual      Stopped      OK      Normal      False False
audstub      Audio Stub Driver c:\winnt\system32\drivers\audstub.sys
      Kernel Driver      True Manual      Running      OK      Normal
      False True
beep      Beep      c:\winnt\system32\drivers\beep.sys      Kernel Driver      True
      System      Running      OK      Normal      False True
buslogic      BusLogic      Not Available      Kernel Driver      False
      Disabled      Stopped      OK      Normal      False False
cd20xrnt      cd20xrnt      Not Available      Kernel Driver      False
      Disabled      Stopped      OK      Normal      False False
cdaudio      Cdaudio      c:\winnt\system32\drivers\cdaudio.sys
      Kernel Driver      False System      Stopped      OK      Ignore
      False False
cdfs      Cdfs      c:\winnt\system32\drivers\cdfs.sys      File System Driver
      True Disabled      Running      OK      Normal      False True
cdrom      CD-ROM Driver      c:\winnt\system32\drivers\cdrom.sys      Kernel
Driver      True System      Running      OK      Normal      False True
changer      Changer      Not Available      Kernel Driver      False
      System      Stopped      OK      Ignore      False False
cpqarray      Cpqarray      Not Available      Kernel Driver      False
      Disabled      Stopped      OK      Normal      False False
cpqarray2      cpqarray2      Not Available      Kernel Driver      False
      Disabled      Stopped      OK      Normal      False False
cpqfcalm      cpqfcalm      Not Available      Kernel Driver      False
      Disabled      Stopped      OK      Normal      False False
cpqfws2e      cpqfws2e      Not Available      Kernel Driver      False
      Disabled      Stopped      OK      Normal      False False
dac960nt      dac960nt      Not Available      Kernel Driver      False
      Disabled      Stopped      OK      Normal      False False
deckzpsx      deckzpsx      Not Available      Kernel Driver      False
      Disabled      Stopped      OK      Normal      False False
dfsdriver      DfsDriver      c:\winnt\system32\drivers\dfs.sys      File System
Driver      True Boot Running      OK      Normal      False True
disk      Disk Driver      c:\winnt\system32\drivers\disk.sys      Kernel Driver
      True Boot Running      OK      Normal      False True
diskperf      Diskperf      c:\winnt\system32\drivers\diskperf.sys
      Kernel Driver      True Boot Running      OK      Normal      False
      True
dmboot      dmboot      c:\winnt\system32\drivers\dmboot.sys
      Kernel Driver      False Disabled      Stopped      OK      Normal
      False False
dmio      Logical Disk Manager Driver      c:\winnt\system32\drivers\dmio.sys
      Kernel Driver      True Boot Running      OK      Normal      False
      True

```

## Appendix C – Tunable Parameters

---

```

dmload      dmload      c:\winnt\system32\drivers\dmload.sys
             Kernel Driver  True Boot Running      OK      Normal      False
             True

e100b Intel PRO Adapter Driver
             c:\winnt\system32\drivers\e100bnt5.sys      Kernel Driver      True
             Manual      Running      OK      Normal      False True

efs EFS c:\winnt\system32\drivers\efs.sys      File System Driver
             True Disabled      Running      OK      Normal      False True

fastfat Fastfat c:\winnt\system32\drivers\fastfat.sys      File
System Driver      True Disabled      Running      OK      Normal      False
True

fd16_700 Fd16_700      Not Available      Kernel Driver      False
Disabled      Stopped      OK      Normal      False False

fdc Floppy Disk Controller Driver c:\winnt\system32\drivers\fdc.sys
Kernel Driver      True Manual      Running      OK      Normal
False True

fireport fireport      Not Available      Kernel Driver      False
Disabled      Stopped      OK      Normal      False False

flashpnt flashpnt      Not Available      Kernel Driver      False
Disabled      Stopped      OK      Normal      False False

flpydisk Floppy Disk Driver
             c:\winnt\system32\drivers\flpydisk.sys      Kernel Driver      True
             Manual      Running      OK      Normal      False True

ftdisk Volume Manager Driver
             c:\winnt\system32\drivers\ftdisk.sys      Kernel Driver      True
             Boot Running      OK      Normal      False True

gnindis cLAN NDIS Driver c:\winnt\system32\drivers\gnindis.sys
Kernel Driver      True Auto Running      OK      Normal      False
True

gnivia cLAN VIA Driver c:\winnt\system32\drivers\gnivia.sys
Kernel Driver      True Auto Running      OK      Normal      False
True

gpc Generic Packet Classifier c:\winnt\system32\drivers\msgpc.sys
Kernel Driver      True Manual      Running      OK      Normal
False True

i8042prt i8042 Keyboard and PS/2 Mouse Port Driver
             c:\winnt\system32\drivers\i8042prt.sys      Kernel Driver      True
             System Running      OK      Normal      False True

ini910u ini910u      Not Available      Kernel Driver      False
Disabled      Stopped      OK      Normal      False False

intelide IntelIde c:\winnt\system32\drivers\intelide.sys
Kernel Driver      True Boot Running      OK      Normal      False
True

ipfilterdriver IP Traffic Filter Driver
             c:\winnt\system32\drivers\ipfltdrv.sys      Kernel Driver      False
             Manual      Stopped      OK      Normal      False False

ipinip IP in IP Tunnel Driver
             c:\winnt\system32\drivers\ipinip.sys      Kernel Driver      False
             Manual      Stopped      OK      Normal      False False

ipnat IP Network Address Translator c:\winnt\system32\drivers\ipnat.sys
Kernel Driver      False Manual      Stopped      OK      Normal
False False

ipsec IPSEC driver c:\winnt\system32\drivers\ipsec.sys Kernel
Driver      False Manual      Stopped      OK      Normal      False False

```

## Appendix C – Tunable Parameters

---

```

ipsraidn    ipsraidn    Not Available    Kernel Driver    False
             Disabled    Stopped         OK    Normal        False False
isapnp      PnP ISA/EISA Bus Driver
             c:\winnt\system32\drivers\isapnp.sys    Kernel Driver    True
             Boot    Running         OK    Critical      False True
kbdclass    Keyboard Class Driver
             c:\winnt\system32\drivers\kbdclass.sys    Kernel Driver    True
             System    Running         OK    Normal        False True
ksecdd      KSecDD          c:\winnt\system32\drivers\ksecdd.sys
             Kernel Driver    True Boot    Running         OK    Normal        False
             True
lbrtfdc     lbrtfdc         Not Available    Kernel Driver    False
             System    Stopped         OK    Ignore        False False
lp6nds35    lp6nds35        Not Available    Kernel Driver    False
             Disabled    Stopped         OK    Normal        False False
mnmdd       mnmdd           c:\winnt\system32\drivers\mnmdd.sys    Kernel Driver    True
             System    Running         OK    Ignore        False True
modem       Modem           c:\winnt\system32\drivers\modem.sys    Kernel Driver    False
             Manual    Stopped         OK    Ignore        False False
mouclass    Mouse Class Driver
             c:\winnt\system32\drivers\mouclass.sys    Kernel Driver    True
             System    Running         OK    Normal        False True
mountmgr    MountMgr        c:\winnt\system32\drivers\mountmgr.sys
             Kernel Driver    True Boot    Running         OK    Normal        False
             True
mraid35x    mraid35x        Not Available    Kernel Driver    False
             Disabled    Stopped         OK    Normal        False False
mrxsmb      MRXSMB          c:\winnt\system32\drivers\mrxsmb.sys
             System Driver    True System    Running         OK    Normal        False
             True
msfs        Msfs            c:\winnt\system32\drivers\msfs.sys    File System Driver
             True System    Running         OK    Normal        False True
mskssrv     Microsoft Streaming Service Proxy
             c:\winnt\system32\drivers\mskssrv.sys    Kernel Driver    False
             Manual    Stopped         OK    Normal        False False
mspclock    Microsoft Streaming Clock Proxy
             c:\winnt\system32\drivers\mspclock.sys    Kernel Driver    False
             Manual    Stopped         OK    Normal        False False
mspqm       Microsoft Streaming Quality Manager Proxy
             c:\winnt\system32\drivers\mspqm.sys    Kernel Driver    False
             Manual    Stopped         OK    Normal        False False
mup         Mup            c:\winnt\system32\drivers\mup.sys    File System Driver
             True Boot    Running         OK    Normal        False True
ncrc710     Ncrc710        Not Available    Kernel Driver    False
             Disabled    Stopped         OK    Normal        False False
ndis        NDIS System Driver
             c:\winnt\system32\drivers\ndis.sys
             Kernel Driver    True Boot    Running         OK    Normal        False
             True
ndistapi    Remote Access NDIS TAPI Driver
             c:\winnt\system32\drivers\ndistapi.sys    Kernel Driver    True
             Manual    Running         OK    Normal        False True
ndiswan     Remote Access NDIS WAN Driver
             c:\winnt\system32\drivers\ndiswan.sys    Kernel Driver    True
             Manual    Running         OK    Normal        False True

```

## Appendix C – Tunable Parameters

---

```

ndproxy      NDIS Proxy      c:\winnt\system32\drivers\ndproxy.sys
              Kernel Driver      True  Manual      Running      OK      Normal
              False True

netbios      NetBIOS Interface c:\winnt\system32\drivers\netbios.sys
              File System Driver      True  System      Running      OK
              Normal      False True

netbt NetBios over Tcpip      c:\winnt\system32\drivers\netbt.sys
              Kernel Driver      True  System      Running      OK      Normal
              False True

netdetect NetDetect      c:\winnt\system32\drivers\netdtect.sys
              Kernel Driver      False Manual      Stopped      OK      Normal
              False False

npfs Npfs      c:\winnt\system32\drivers\npfs.sys File System Driver
              True System      Running      OK      Normal      False True

ntfs Ntfs      c:\winnt\system32\drivers\ntfs.sys File System Driver
              True Disabled      Running      OK      Normal      False True

null Null      c:\winnt\system32\drivers\null.sys Kernel Driver      True
              System      Running      OK      Normal      False True

nwlkflt      IPX Traffic Filter Driver
              c:\winnt\system32\drivers\nwlkflt.sys Kernel Driver      False
              Manual      Stopped      OK      Normal      False False

nwlkfwfwd      IPX Traffic Forwarder Driver
              c:\winnt\system32\drivers\nwlkfwfwd.sys Kernel Driver      False
              Manual      Stopped      OK      Normal      False False

parallel      Parallel class driver
              c:\winnt\system32\drivers\parallel.sys Kernel Driver      True
              Manual      Running      OK      Normal      False True

parport      Parallel port driver
              c:\winnt\system32\drivers\parport.sys Kernel Driver      True
              System      Running      OK      Ignore      False True

partmgr      PartMgr      c:\winnt\system32\drivers\partmgr.sys
              Kernel Driver      True  Boot Running      OK      Normal      False
              True

parvdm      ParVdm      c:\winnt\system32\drivers\parvdm.sys
              Kernel Driver      True  Auto Running      OK      Ignore      False
              True

pci PCI Bus Driver      c:\winnt\system32\drivers\pci.sys Kernel
Driver      True  Boot Running      OK      Critical      False True

pcidump      PCIDump      Not Available      Kernel Driver      False
              System      Stopped      OK      Ignore      False False

pciide      PCIIDE      Not Available      Kernel Driver      False
              Disabled      Stopped      OK      Normal      False False

pcmcia      Pcmcia      c:\winnt\system32\drivers\pcmcia.sys
              Kernel Driver      False Disabled      Stopped      OK      Normal
              False False

pdcomp      PDCOMP      Not Available      Kernel Driver      False
              Manual      Stopped      OK      Ignore      False False

pdframe      PDFRAME      Not Available      Kernel Driver      False
              Manual      Stopped      OK      Ignore      False False

pdreli      PDRELI      Not Available      Kernel Driver      False
              Manual      Stopped      OK      Ignore      False False

pdrframe      PDRFRAME      Not Available      Kernel Driver      False
              Manual      Stopped      OK      Ignore      False False

```

## Appendix C – Tunable Parameters

---

```

pptpminiport      WAN Miniport (PPTP)
  c:\winnt\system32\drivers\raspttp.sys      Kernel Driver      True
  Manual      Running      OK      Normal      False True
ptilink          Direct Parallel Link Driver
  c:\winnt\system32\drivers\ptilink.sys      Kernel Driver      True
  Manual      Running      OK      Normal      False True
ql1080          ql1080      Not Available      Kernel Driver      False
  Disabled    Stopped      OK      Normal      False False
ql10wnt         Ql10wnt      Not Available      Kernel Driver      False
  Disabled    Stopped      OK      Normal      False False
ql1240          ql1240      Not Available      Kernel Driver      False
  Disabled    Stopped      OK      Normal      False False
ql2100          ql2100      Not Available      Kernel Driver      False
  Disabled    Stopped      OK      Normal      False False
rasacd          Remote Access Auto Connection Driver
  c:\winnt\system32\drivers\rasacd.sys      Kernel Driver      True
  System      Running      OK      Normal      False True
rasl2tp         WAN Miniport (L2TP)
  c:\winnt\system32\drivers\rasl2tp.sys     Kernel Driver      True
  Manual      Running      OK      Normal      False True
raspti          Direct Parallel  c:\winnt\system32\drivers\raspti.sys
  Kernel Driver      True Manual      Running      OK      Normal
  False True
rca             Microsoft Streaming Network Raw Channel Access
  c:\winnt\system32\drivers\rca.sys        Kernel Driver      False
  Manual      Stopped      OK      Normal      False False
rdbss           Rdbss c:\winnt\system32\drivers\rdbss.sys File System Driver
  True System      Running      OK      Normal      False True
rdpwd           RDPWD c:\winnt\system32\drivers\rdpwd.sys Kernel Driver      False
  Manual      Stopped      OK      Ignore      False False
redbook        Digital CD Audio Playback Filter Driver
  c:\winnt\system32\drivers\redbook.sys    Kernel Driver      False
  System      Stopped      OK      Normal      False False
serenum        Serenum Filter Driver
  c:\winnt\system32\drivers\serenum.sys    Kernel Driver      True
  Manual      Running      OK      Normal      False True
serial         Serial port driver
  c:\winnt\system32\drivers\serial.sys     Kernel Driver      True
  System      Running      OK      Ignore      False True
sfloppy        Sfloppy c:\winnt\system32\drivers\sfloppy.sys
  Kernel Driver      False System      Stopped      OK      Ignore
  False False
sglfb          sglfb Not Available      Kernel Driver      False System
  Stopped      OK      Normal      False False
simbad         Simbad      Not Available      Kernel Driver      False
  Disabled    Stopped      OK      Normal      False False
sparrow        Sparrow      Not Available      Kernel Driver      False
  Disabled    Stopped      OK      Normal      False False
spud           Special Purpose Utility Driver
  c:\winnt\system32\drivers\spud.sys       Kernel Driver      True
  Manual      Running      OK      Normal      False True
srv            Srv c:\winnt\system32\drivers\srv.sys File System Driver
  True Manual      Running      OK      Normal      False True

```

## Appendix C – Tunable Parameters

---

```

swenum      Software Bus Driver
             c:\winnt\system32\drivers\swenum.sys      Kernel Driver      True
             Manual      Running      OK      Normal      False True
symc810     symc810      Not Available      Kernel Driver      False
             Disabled    Stopped      OK      Normal      False False
symc8xx     symc8xx      Not Available      Kernel Driver      False
             Disabled    Stopped      OK      Normal      False False
sym_hi      sym_hi      Not Available      Kernel Driver      False
             Disabled    Stopped      OK      Normal      False False
tcpip       TCP/IP Protocol Driver  c:\winnt\system32\drivers\tcpip.sys
             Kernel Driver      True      System      Running      OK      Normal
             False True
tdasync     TDASYNC      c:\winnt\system32\drivers\tdasync.sys
             Kernel Driver      False Manual      Stopped      OK      Ignore
             False False
tdipx       TDIPX      c:\winnt\system32\drivers\tdipx.sys Kernel Driver      False
             Manual      Stopped      OK      Ignore      False False
tdnetb      TDNETB      c:\winnt\system32\drivers\tdnetb.sys
             Kernel Driver      False Manual      Stopped      OK      Ignore
             False False
tdpipe      TDPIPE      c:\winnt\system32\drivers\tdpipe.sys
             Kernel Driver      False Manual      Stopped      OK      Ignore
             False False
tdspx       TDSPX      c:\winnt\system32\drivers\tdspx.sys Kernel Driver      False
             Manual      Stopped      OK      Ignore      False False
tdtcp       TDTCP      c:\winnt\system32\drivers\tdtcp.sys Kernel Driver      False
             Manual      Stopped      OK      Ignore      False False
termdd      Terminal Device Driver
             c:\winnt\system32\drivers\termdd.sys      Kernel Driver      False
             Disabled    Stopped      OK      Normal      False False
tga         tga      Not Available      Kernel Driver      False System
             Stopped      OK      Ignore      False False
udfs        Udfs      c:\winnt\system32\drivers\udfs.sys  File System Driver
             False Disabled    Stopped      OK      Normal      False False
uhcd        Microsoft USB Universal Host Controller Driver
             c:\winnt\system32\drivers\uhcd.sys      Kernel Driver      True
             Manual      Running      OK      Normal      False True
ultra66     ultra66     Not Available      Kernel Driver      False
             Disabled    Stopped      OK      Normal      False False
update      Microcode Update Driver
             c:\winnt\system32\drivers\update.sys      Kernel Driver      True
             Manual      Running      OK      Normal      False True
usbhub      Microsoft USB Standard Hub Driver
             c:\winnt\system32\drivers\usbhub.sys      Kernel Driver      True
             Manual      Running      OK      Normal      False True
vgasave    VgaSave      c:\winnt\system32\drivers\vga.sys    Kernel
Driver      True System      Running      OK      Ignore      False True
wanarp      Remote Access IP ARP Driver
             c:\winnt\system32\drivers\wanarp.sys      Kernel Driver      True
             Manual      Running      OK      Normal      False True
wdica       WDICA      Not Available      Kernel Driver      False Manual
             Stopped      OK      Ignore      False False

```

[Environment Variables]

## Appendix C – Tunable Parameters

---

```

Variable      Value User Name
ComSpec       %SystemRoot%\system32\cmd.exe <SYSTEM>
HOME          C:/ <SYSTEM>
NUMBER_OF_PROCESSORS 1 <SYSTEM>
OS            Windows_NT <SYSTEM>
Os2LibPath    %SystemRoot%\system32\os2\dll; <SYSTEM>
Path
    C:\MKS\mksnt;C:\WINNT\system32;C:\WINNT;C:\WINNT\System32\Wbem;C:
\Program Files\Microsoft SQL
Server\80\Tools\BINN;C:\SQL_2K_ENT\x86\bin;.; <SYSTEM>
PATHEXT       .COM;.EXE;.BAT;.CMD;.VBS;.VBE;.JS;.JSE;.WSF;.WSH
<SYSTEM>
PROCESSOR_ARCHITECTURE x86 <SYSTEM>
PROCESSOR_IDENTIFIER x86 Family 6 Model 7 Stepping 3, GenuineIntel
<SYSTEM>
PROCESSOR_LEVEL 6 <SYSTEM>
PROCESSOR_REVISION 0703 <SYSTEM>
ROOTDIR       C:/MKS <SYSTEM>
SHELL         C:/MKS/mksnt/sh.exe <SYSTEM>
TEMP          %SystemRoot%\TEMP <SYSTEM>
TMP           %SystemRoot%\TEMP <SYSTEM>
TMPDIR        C:/WINNT/TEMP <SYSTEM>
windir        %SystemRoot% <SYSTEM>
TEMP          %USERPROFILE%\Local Settings\Temp CLIENT2\Administrator
TMP           %USERPROFILE%\Local Settings\Temp CLIENT2\Administrator

```

[Jobs]

[ Following are sub-categories of this main category ]

[Print]

Document	Size	Owner	Notify	Status	Time Submitted	Start
Time	Until	Time	Elapsed	Pages	Printed	Job ID
Priority	Parameters	Driver	Name	Print	Processor	Host
Queue	Data	Type	Name			Print
Unknown	Unknown	Unknown	Unknown	Unknown	Unknown	Unknown
	Unknown	Unknown	Unknown	Unknown	Unknown	
	Unknown	Unknown	Unknown	Unknown	Unknown	
	Unknown	Unknown				

[Network Connections]

Local Name	Remote Name	Type	Status	User Name
No network connections information				

[Running Tasks]

Name	Path	Process ID	Priority	Min Working Set	Max Working Set
	Start Time	Version	Size	File Date	
system	idle	process	Not Available	0	0
	Not Available		Not Available	Unknown	Unknown
	Unknown				
system	Not Available		8	8	0
Available	Unknown	Unknown	Unknown	Unknown	1413120
					Not

## Appendix C – Tunable Parameters

---

```
smss.exe      c:\winnt\system32\smss.exe      156   11   204800
              1413120      10/13/2000 4:26:26 PM      5.00.2195.31      44.27 KB
(45,328 bytes) 12/7/1999 6:00:00 AM
csrss.exe    Not Available      184   13   Not Available      Not
Available      10/13/2000 4:26:30 PM      Unknown      Unknown      Unknown
winlogon.exe c:\winnt\system32\winlogon.exe   180   13
              204800      1413120      10/13/2000 4:26:31 PM      5.00.2195.1600
              172.77 KB (176,912 bytes) 12/7/1999 6:00:00 AM
services.exe c:\winnt\system32\services.exe   232   9
              204800      1413120      10/13/2000 4:26:33 PM      5.00.2134.1 86.77
KB (88,848 bytes) 12/7/1999 6:00:00 AM
lsass.exe    c:\winnt\system32\lsass.exe      244   13   204800
              1413120      10/13/2000 4:26:33 PM      5.00.2195.1620      32.77 KB
(33,552 bytes) 12/7/1999 6:00:00 AM
gnconmgr.exe c:\winnt\system32\gnconmgr.exe    372   8
              204800      1413120      10/13/2000 4:26:38 PM      4.1.1 128.05 KB
(131,119 bytes) 9/13/2000 3:45:58 PM
svchost.exe c:\winnt\system32\svchost.exe    420   8   204800
              1413120      10/13/2000 4:26:39 PM      5.00.2134.1 7.77 KB (7,952
bytes) 12/7/1999 6:00:00 AM
msdtc.exe    c:\winnt\system32\msdtc.exe      448   8   204800
              1413120      10/13/2000 4:26:40 PM      1999.9.3421.3      6.77 KB
(6,928 bytes) 9/13/2000 6:25:55 AM
svchost.exe c:\winnt\system32\svchost.exe    552   8   204800
              1413120      10/13/2000 4:26:42 PM      5.00.2134.1 7.77 KB (7,952
bytes) 12/7/1999 6:00:00 AM
regsvc.exe   c:\winnt\system32\regsvc.exe      580   8   204800
              1413120      10/13/2000 4:26:42 PM      5.00.2195.31      65.27 KB
(66,832 bytes) 9/15/2000 3:01:52 PM
mstask.exe   c:\winnt\system32\mstask.exe      596   8   204800
              1413120      10/13/2000 4:26:43 PM      4.71.2137.1 115.27 KB
(118,032 bytes) 9/13/2000 11:25:44 AM
tcpsvcs.exe  c:\winnt\system32\tcpsvcs.exe    648   8   204800
              1413120      10/13/2000 4:26:45 PM      5.00.2134.1 24.77 KB (25,360
bytes) 12/7/1999 6:00:00 AM
winmgmt.exe c:\winnt\system32\wbem\winmgmt.exe 672   8   204800
              1413120      10/13/2000 4:26:45 PM      1.50.1085.0009      192.08 KB
(196,685 bytes) 9/15/2000 3:02:35 PM
inetinfo.exe c:\winnt\system32\inetinfo.exe    740   8
              204800      1413120      10/13/2000 4:26:52 PM      5.00.0984 14.27
KB (14,608 bytes) 9/15/2000 3:03:43 PM
explorer.exe c:\winnt\explorer.exe            824   8   204800
              1413120      10/13/2000 4:26:55 PM      5.00.3103.1000      237.27 KB
(242,960 bytes) 9/15/2000 3:02:27 PM
svchost.exe c:\winnt\system32\svchost.exe    828   8   204800
              1413120      10/13/2000 4:29:41 PM      5.00.2134.1 7.77 KB (7,952
bytes) 12/7/1999 6:00:00 AM
mmc.exe      c:\winnt\system32\mmc.exe         736   8   204800
              1413120      10/15/2000 5:06:42 PM      5.00.2153.1 589.27 KB
(603,408 bytes) 12/7/1999 6:00:00 AM
rsvp.exe     c:\winnt\system32\rsvp.exe        1120  8   204800
              1413120      10/15/2000 5:08:07 PM      5.00.2167.1 172.77 KB
(176,912 bytes) 12/7/1999 6:00:00 AM
```

[Loaded Modules]

## Appendix C – Tunable Parameters

---

Name	Version	Size	File Date	Manufacturer	Path
traffic.dll	5.00.2139.1	30.77 KB (31,504 bytes)	12/7/1999 6:00:00 AM	Microsoft Corporation	c:\winnt\system32\traffic.dll
rsvp.exe	5.00.2167.1	172.77 KB (176,912 bytes)	12/7/1999 6:00:00 AM	Microsoft Corporation	c:\winnt\system32\rsvp.exe
wbemprox.dll	1.50.1085.0015	40.08 KB (41,040 bytes)	9/15/2000 3:02:35 PM	Microsoft Corporation	c:\winnt\system32\wbem\wbemprox.dll
mlang.dll	5.00.3103.1000	510.77 KB (523,024 bytes)	9/15/2000 3:02:09 PM	Microsoft Corporation	c:\winnt\system32\mlang.dll
rassapi.dll	5.00.2188.1	14.27 KB (14,608 bytes)	12/7/1999 6:00:00 AM	Microsoft Corporation	c:\winnt\system32\rassapi.dll
adsnt.dll	5.00.2195.1600	194.27 KB (198,928 bytes)	9/15/2000 3:02:22 PM	Microsoft Corporation	c:\winnt\system32\adsnt.dll
dbghelp.dll	5.00.2195.1	159.27 KB (163,088 bytes)	12/7/1999 6:00:00 AM	Microsoft Corporation	c:\winnt\system32\dbghelp.dll
localesec.dll	5.00.2195.1340	227.27 KB (232,720 bytes)	9/15/2000 3:02:09 PM	Microsoft Corporation	c:\winnt\system32\localesec.dll
devmgr.dll	5.00.2166.1	215.77 KB (220,944 bytes)	12/7/1999 6:00:00 AM	Microsoft Corporation	c:\winnt\system32\devmgr.dll
filemgmt.dll	5.00.2134.1	287.27 KB (294,160 bytes)	12/7/1999 6:00:00 AM	Microsoft Corporation	c:\winnt\system32\filemgmt.dll
pdh.dll	5.00.2195.1600	143.27 KB (146,704 bytes)	9/15/2000 3:01:55 PM	Microsoft Corporation	c:\winnt\system32\pdh.dll
smlogcfg.dll	5.00.2163.1	273.27 KB (279,824 bytes)	12/7/1999 6:00:00 AM	Microsoft Corporation	c:\winnt\system32\smlogcfg.dll
cabinet.dll	5.00.2147.1	54.77 KB (56,080 bytes)	12/7/1999 6:00:00 AM	Microsoft Corporation	c:\winnt\system32\cabinet.dll
msinfo32.dll	5.00.2177.1	312.27 KB (319,760 bytes)	9/13/2000 11:25:52 AM	Microsoft Corporation	c:\program files\common files\microsoft shared\msinfo\msinfo32.dll
riched20.dll	5.30.23.1203	421.27 KB (431,376 bytes)	9/15/2000 3:01:52 PM	Microsoft Corporation	c:\winnt\system32\riched20.dll
riched32.dll	5.00.2134.1	3.77 KB (3,856 bytes)	12/7/1999 6:00:00 AM	Microsoft Corporation	c:\winnt\system32\riched32.dll
els.dll	5.00.2175.1	151.27 KB (154,896 bytes)	12/7/1999 6:00:00 AM	Microsoft Corporation	c:\winnt\system32\els.dll
ntmsmgr.dll	1,0,0,1	427.77 KB (438,032 bytes)	12/7/1999 6:00:00 AM	Microsoft Corporation and HighGround Systems, Inc.	c:\winnt\system32\ntmsmgr.dll
mmfutil.dll	1.50.1085.0000	32.06 KB (32,829 bytes)	12/7/1999 6:00:00 AM	Microsoft Corporation	c:\winnt\system32\mmfutil.dll
logdrive.dll	1.50.1085.0000	200.06 KB (204,863 bytes)	12/7/1999 6:00:00 AM	Microsoft Corporation	c:\winnt\system32\logdrive.dll
dfrgres.dll	5.00.2150.1	27.50 KB (28,160 bytes)	12/7/1999 6:00:00 AM	Executive Software International, Inc.	c:\winnt\system32\dfrgres.dll
dfrgsnap.dll	5.00.2195.31	41.77 KB (42,768 bytes)	9/15/2000 3:02:17 PM	Executive Software International, Inc.	c:\winnt\system32\dfrgsnap.dll

## Appendix C – Tunable Parameters

---

dmdskres.dll 2191.1.296.2 119.00 KB (121,856 bytes)  
12/7/1999 6:00:00 AM Microsoft Corp., VERITAS Software  
c:\winnt\system32\dmdskres.dll

dmutil.dll 2195.23.297.2 42.27 KB (43,280 bytes) 9/15/2000 3:02:16  
PM VERITAS Software Corp. c:\winnt\system32\dmutil.dll

ntmsapi.dll 5.00.1948.1 50.27 KB (51,472 bytes) 9/15/2000 3:01:59 PM  
Microsoft Corporation c:\winnt\system32\ntmsapi.dll

dmdskmgr.dll 2195.1600.297.3 160.27 KB (164,112 bytes)  
9/15/2000 3:02:16 PM Microsoft Corp., VERITAS Software  
c:\winnt\system32\dmdskmgr.dll

mycomput.dll 5.00.2134.1 107.77 KB (110,352 bytes) 12/7/1999  
6:00:00 AM Microsoft Corporation c:\winnt\system32\mycomput.dll

mmcndmgr.dll 5.00.2178.1 815.27 KB (834,832 bytes) 12/7/1999  
6:00:00 AM Microsoft Corporation c:\winnt\system32\mmcndmgr.dll

mfc42u.dll 6.00.8665.0 972.05 KB (995,384 bytes) 12/7/1999 6:00:00  
AM Microsoft Corporation c:\winnt\system32\mfc42u.dll

mmc.exe 5.00.2153.1 589.27 KB (603,408 bytes) 12/7/1999 6:00:00  
AM Microsoft Corporation c:\winnt\system32\mmc.exe

tapisrv.dll 5.00.2186.1 168.77 KB (172,816 bytes) 12/7/1999 6:00:00  
AM Microsoft Corporation c:\winnt\system32\tapisrv.dll

wininet.dll 5.00.3103.1000 456.77 KB (467,728 bytes) 9/15/2000  
3:01:46 PM Microsoft Corporation c:\winnt\system32\wininet.dll

shdoclc.dll 5.00.3103.1000 324.50 KB (332,288 bytes) 9/15/2000  
3:01:50 PM Microsoft Corporation c:\winnt\system32\shdoclc.dll

faxshell.dll 5.00.2134.1 8.27 KB (8,464 bytes) 12/7/1999 6:00:00  
AM Microsoft Corporation c:\winnt\system32\faxshell.dll

msacm32.dll 5.00.2134.1 65.27 KB (66,832 bytes) 12/7/1999 6:00:00 AM  
Microsoft Corporation c:\winnt\system32\msacm32.dll

avifil32.dll 5.00.2134.1 76.27 KB (78,096 bytes) 12/7/1999 6:00:00  
AM Microsoft Corporation c:\winnt\system32\avifil32.dll

msvfw32.dll 5.00.2134.1 113.77 KB (116,496 bytes) 12/7/1999 6:00:00  
AM Microsoft Corporation c:\winnt\system32\msvfw32.dll

docprop2.dll 5.00.2178.1 297.77 KB (304,912 bytes) 12/7/1999  
6:00:00 AM Microsoft Corporation c:\winnt\system32\docprop2.dll

mydocs.dll 5.00.2920.0000 55.77 KB (57,104 bytes) 12/7/1999 6:00:00  
AM Microsoft Corporation c:\winnt\system32\mydocs.dll

msi.dll 1.11.1314.0 1.72 MB (1,798,928 bytes) 9/15/2000 3:02:05  
PM Microsoft Corporation c:\winnt\system32\msi.dll

urlmon.dll 5.00.3103.1000 440.77 KB (451,344 bytes) 9/15/2000  
3:01:47 PM Microsoft Corporation c:\winnt\system32\urlmon.dll

ntshrui.dll 5.00.2134.1 46.77 KB (47,888 bytes) 12/7/1999 6:00:00 AM  
Microsoft Corporation c:\winnt\system32\ntshrui.dll

linkinfo.dll 5.00.2134.1 15.77 KB (16,144 bytes) 12/7/1999 6:00:00  
AM Microsoft Corporation c:\winnt\system32\linkinfo.dll

browselc.dll 5.00.3103.1000 34.50 KB (35,328 bytes) 9/15/2000  
3:02:21 PM Microsoft Corporation c:\winnt\system32\browselc.dll

powrprof.dll 5.00.3103.1000 13.27 KB (13,584 bytes) 9/15/2000  
3:01:54 PM Microsoft Corporation c:\winnt\system32\powrprof.dll

batmeter.dll 5.00.2920.0000 20.27 KB (20,752 bytes) 9/15/2000  
3:02:21 PM Microsoft Corporation c:\winnt\system32\batmeter.dll

stobject.dll 5.00.2195.1387 79.27 KB (81,168 bytes) 9/15/2000  
3:01:48 PM Microsoft Corporation c:\winnt\system32\stobject.dll

webcheck.dll 5.00.3103.1000 251.77 KB (257,808 bytes)  
9/15/2000 3:01:47 PM Microsoft Corporation  
c:\winnt\system32\webcheck.dll

## Appendix C – Tunable Parameters

---

```
browseui.dll      5.00.3103.1000    788.77 KB (807,696 bytes)
                  9/15/2000 3:02:21 PM    Microsoft Corporation
                  c:\winnt\system32\browseui.dll
shdocvw.dll      5.00.3103.1000    1.05 MB (1,104,144 bytes)    9/15/2000
3:01:49 PM    Microsoft Corporation    c:\winnt\system32\shdocvw.dll
explorer.exe     5.00.3103.1000    237.27 KB (242,960 bytes)
                  9/15/2000 3:02:27 PM    Microsoft Corporation
                  c:\winnt\explorer.exe
iislog.dll       5.00.0984    75.77 KB (77,584 bytes)    9/15/2000 3:03:44 PM
                  Microsoft Corporation    c:\winnt\system32\inetsrv\iislog.dll
httpext.dll      0.9.3940.2    418.27 KB (428,304 bytes)    9/15/2000 3:03:44
PM    Microsoft Corporation    c:\winnt\system32\inetsrv\httpext.dll
rpcproxy.dll     5.00.2176.1    16.27 KB (16,656 bytes)    9/13/2000 6:25:47
AM    Microsoft Corporation    c:\winnt\system32\rpcproxy\rpcproxy.dll
fpexedll.dll    4.0.2.4022    20.06 KB (20,541 bytes)    9/15/2000 3:03:36
PM    Microsoft Corporation    c:\program files\common files\microsoft
shared\web server extensions\40\bin\fpexedll.dll
md5filt.dll     5.00.0984    32.77 KB (33,552 bytes)    9/15/2000 3:03:43 PM
                  Microsoft Corporation    c:\winnt\system32\inetsrv\md5filt.dll
gzip.dll        5.00.0984    30.27 KB (30,992 bytes)    9/15/2000 3:03:44 PM
                  Microsoft Corporation    c:\winnt\system32\inetsrv\gzip.dll
compfilt.dll    5.00.0984    22.27 KB (22,800 bytes)    9/15/2000 3:03:45
PM    Microsoft Corporation    c:\winnt\system32\inetsrv\compfilt.dll
sspifilt.dll    5.00.0984    43.27 KB (44,304 bytes)    9/15/2000 3:03:42
PM    Microsoft Corporation    c:\winnt\system32\inetsrv\sspifilt.dll
iscomlog.dll    5.00.0984    24.77 KB (25,360 bytes)    9/15/2000 3:03:43
PM    Microsoft Corporation    c:\winnt\system32\inetsrv\iscomlog.dll
lonsint.dll     5.00.0984    11.77 KB (12,048 bytes)    9/15/2000 3:03:43 PM
                  Microsoft Corporation    c:\winnt\system32\inetsrv\lonsint.dll
inetsloc.dll    5.00.0984    20.27 KB (20,752 bytes)    9/15/2000 3:02:11
PM    Microsoft Corporation    c:\winnt\system32\inetsloc.dll
iisfecnv.dll    5.00.0984    7.27 KB (7,440 bytes)    9/13/2000 6:26:47
AM    Microsoft Corporation    c:\winnt\system32\inetsrv\iisfecnv.dll
isatq.dll       5.00.0984    60.27 KB (61,712 bytes)    9/15/2000 3:03:43 PM
                  Microsoft Corporation    c:\winnt\system32\inetsrv\isatq.dll
infocomm.dll    5.00.0984    229.77 KB (235,280 bytes)    9/15/2000
3:03:43 PM    Microsoft Corporation
                  c:\winnt\system32\inetsrv\infocomm.dll
w3svc.dll       5.00.0984    342.77 KB (350,992 bytes)    9/15/2000 3:03:42
PM    Microsoft Corporation    c:\winnt\system32\inetsrv\w3svc.dll
security.dll    5.00.2154.1    5.77 KB (5,904 bytes)    12/7/1999 6:00:00
AM    Microsoft Corporation    c:\winnt\system32\security.dll
svcext.dll     5.00.0984    39.77 KB (40,720 bytes)    9/15/2000 3:03:42 PM
                  Microsoft Corporation    c:\winnt\system32\inetsrv\svcext.dll
admexs.dll     5.00.0984    27.77 KB (28,432 bytes)    9/15/2000 3:03:45 PM
                  Microsoft Corporation    c:\winnt\system32\inetsrv\admexs.dll
wamreg.dll     5.00.0984    45.77 KB (46,864 bytes)    9/15/2000 3:03:41 PM
                  Microsoft Corporation    c:\winnt\system32\inetsrv\wamreg.dll
metadata.dll    5.00.0984    68.27 KB (69,904 bytes)    9/15/2000 3:03:42
PM    Microsoft Corporation    c:\winnt\system32\inetsrv\metadata.dll
iismap.dll     5.00.0984    55.77 KB (57,104 bytes)    9/15/2000 3:02:12 PM
                  Microsoft Corporation    c:\winnt\system32\iismap.dll
nsepm.dll      5.00.0984    43.27 KB (44,304 bytes)    9/15/2000 3:03:42 PM
                  Microsoft Corporation    c:\winnt\system32\inetsrv\nsepm.dll
```

## Appendix C – Tunable Parameters

---

```
admwprox.dll      5.00.0984    31.77 KB (32,528 bytes) 9/13/2000 6:26:48
AM Microsoft Corporation c:\winnt\system32\admwprox.dll
coadmin.dll 5.00.0984    39.27 KB (40,208 bytes) 9/15/2000 3:03:45 PM
Microsoft Corporation c:\winnt\system32\inetsrv\coadmin.dll
iisadmin.dll      5.00.0984    15.27 KB (15,632 bytes) 9/15/2000 3:03:44
PM Microsoft Corporation c:\winnt\system32\inetsrv\iisadmin.dll
rpcref.dll 5.00.0984    4.27 KB (4,368 bytes) 9/15/2000 3:03:42 PM
Microsoft Corporation c:\winnt\system32\inetsrv\rpcref.dll
iisrtl.dll 5.00.0984    120.27 KB (123,152 bytes) 9/15/2000 3:02:12
PM Microsoft Corporation c:\winnt\system32\iisrtl.dll
inetinfo.exe      5.00.0984    14.27 KB (14,608 bytes) 9/15/2000 3:03:43
PM Microsoft Corporation c:\winnt\system32\inetsrv\inetinfo.exe
netui1.dll 5.00.2134.1 210.27 KB (215,312 bytes) 12/7/1999 6:00:00
AM Microsoft Corporation c:\winnt\system32\netui1.dll
netui0.dll 5.00.2134.1 70.27 KB (71,952 bytes) 12/7/1999 6:00:00 AM
Microsoft Corporation c:\winnt\system32\netui0.dll
ntlanman.dll      5.00.2157.1 35.27 KB (36,112 bytes) 12/7/1999 6:00:00
AM Microsoft Corporation c:\winnt\system32\ntlanman.dll
wshnetbs.dll      5.00.2134.1 7.77 KB (7,952 bytes) 12/7/1999 6:00:00
AM Microsoft Corporation c:\winnt\system32\wshnetbs.dll
rapilib.dll 5.00.2167.1 25.27 KB (25,872 bytes) 12/7/1999 6:00:00 AM
Microsoft Corporation c:\winnt\system32\rapilib.dll
rsvpsp.dll 5.00.2167.1 74.77 KB (76,560 bytes) 12/7/1999 6:00:00 AM
Microsoft Corporation c:\winnt\system32\rsvpsp.dll
ntmarta.dll 5.00.2158.1 98.77 KB (101,136 bytes) 12/7/1999 6:00:00
AM Microsoft Corporation c:\winnt\system32\ntmarta.dll
provthrd.dll      1.50.1085.0000 68.07 KB (69,708 bytes) 9/13/2000
11:25:43 AM Microsoft Corporation c:\winnt\system32\wbem\provthrd.dll
ntevt.dll 1.50.1085.0000 192.06 KB (196,669 bytes) 12/7/1999
6:00:00 AM Microsoft Corporation c:\winnt\system32\wbem\ntevt.dll
perfos.dll 5.00.2155.1 21.27 KB (21,776 bytes) 12/7/1999 6:00:00 AM
Microsoft Corporation c:\winnt\system32\perfos.dll
psapi.dll 5.00.2134.1 28.27 KB (28,944 bytes) 12/7/1999 6:00:00 AM
Microsoft Corporation c:\winnt\system32\psapi.dll
framedyn.dll      1.50.1085.0000 164.05 KB (167,992 bytes)
12/7/1999 6:00:00 AM Microsoft Corporation
c:\winnt\system32\wbem\framedyn.dll
cimwin32.dll      1.50.1085.0016 1.02 MB (1,073,232 bytes)
9/15/2000 3:02:37 PM Microsoft Corporation
c:\winnt\system32\wbem\cimwin32.dll
wbemsvc.dll 1.50.1085.0007 40.07 KB (41,036 bytes) 9/15/2000 3:02:35
PM Microsoft Corporation c:\winnt\system32\wbem\wbemsvc.dll
wbemess.dll 1.50.1085.0007 364.07 KB (372,804 bytes) 9/15/2000
3:02:35 PM Microsoft Corporation c:\winnt\system32\wbem\wbemess.dll
fastprox.dll      1.50.1085.0007 144.08 KB (147,536 bytes)
9/15/2000 3:02:36 PM Microsoft Corporation
c:\winnt\system32\wbem\fastprox.dll
wbemcore.dll      1.50.1085.0008 628.07 KB (643,140 bytes)
9/15/2000 3:02:35 PM Microsoft Corporation
c:\winnt\system32\wbem\wbemcore.dll
wbemcomn.dll      1.50.1085.0007 692.07 KB (708,675 bytes)
9/15/2000 3:02:36 PM Microsoft Corporation
c:\winnt\system32\wbem\wbemcomn.dll
winmgmt.exe 1.50.1085.0009 192.08 KB (196,685 bytes) 9/15/2000
3:02:35 PM Microsoft Corporation c:\winnt\system32\wbem\winmgmt.exe
```

## Appendix C – Tunable Parameters

---

```
simptcp.dll 5.00.2134.1 19.27 KB (19,728 bytes) 9/13/2000 6:25:46 AM
    Microsoft Corporation c:\winnt\system32\simptcp.dll
tcpsvcs.exe 5.00.2134.1 24.77 KB (25,360 bytes) 12/7/1999 6:00:00 AM
    Microsoft Corporation c:\winnt\system32\tcpsvcs.exe
msidle.dll 5.00.2920.0000 6.27 KB (6,416 bytes) 12/7/1999 6:00:00
AM Microsoft Corporation c:\winnt\system32\msidle.dll
mstask.exe 4.71.2137.1 115.27 KB (118,032 bytes) 9/13/2000
11:25:44 AM Microsoft Corporation c:\winnt\system32\mstask.exe
regsvc.exe 5.00.2195.31 65.27 KB (66,832 bytes) 9/15/2000 3:01:52
PM Microsoft Corporation c:\winnt\system32\regsvc.exe
wmi.dll 5.00.2191.1 6.27 KB (6,416 bytes) 12/7/1999 6:00:00 AM
    Microsoft Corporation c:\winnt\system32\wmi.dll
netshell.dll 5.00.2195.1600 456.77 KB (467,728 bytes)
9/15/2000 3:02:00 PM Microsoft Corporation
c:\winnt\system32\netshell.dll
netman.dll 5.00.2195.1600 89.27 KB (91,408 bytes) 9/15/2000 3:02:00
PM Microsoft Corporation c:\winnt\system32\netman.dll
rasdlg.dll 5.00.2194.1 514.27 KB (526,608 bytes) 12/7/1999 6:00:00
AM Microsoft Corporation c:\winnt\system32\rasdlg.dll
netcfgx.dll 5.00.2195.1618 533.77 KB (546,576 bytes) 9/15/2000
3:02:01 PM Microsoft Corporation c:\winnt\system32\netcfgx.dll
rasmans.dll 5.00.2195.27 146.77 KB (150,288 bytes) 9/15/2000
3:01:53 PM Microsoft Corporation c:\winnt\system32\rasmans.dll
iashlpr.dll 5.00.2184.1 33.27 KB (34,064 bytes) 12/7/1999 6:00:00 AM
    Microsoft Corporation c:\winnt\system32\iashlpr.dll
iasacct.dll 5.00.2134.1 28.27 KB (28,944 bytes) 12/7/1999 6:00:00 AM
    Microsoft Corporation c:\winnt\system32\iasacct.dll
iasuser.dll 5.00.2134.1 25.77 KB (26,384 bytes) 12/7/1999 6:00:00
AM Microsoft Corporation c:\winnt\system32\iasuser.dll
iasnap.dll 5.00.2134.1 58.77 KB (60,176 bytes) 12/7/1999 6:00:00 AM
    Microsoft Corporation c:\winnt\system32\iasnap.dll
iaspipe.dll 5.00.2134.1 41.77 KB (42,768 bytes) 12/7/1999 6:00:00 AM
    Microsoft Corporation c:\winnt\system32\iaspipe.dll
expsrv.dll 6.0.8540 370.27 KB (379,152 bytes) 9/15/2000 3:02:14
PM Microsoft Corporation c:\winnt\system32\expsrv.dll
vbajet32.dll 6.1.8268 30.27 KB (30,992 bytes) 9/15/2000 3:01:47
PM Microsoft Corporation c:\winnt\system32\vbajet32.dll
msjtes40.dll 4.00.3714.5 236.27 KB (241,936 bytes) 9/15/2000
3:02:03 PM Microsoft Corporation c:\winnt\system32\msjtes40.dll
oledb32r.dll 2.60.6526.0 68.27 KB (69,904 bytes) 9/13/2000 4:44:24
PM Microsoft Corporation c:\program files\common files\system\ole
db\oledb32r.dll
comdlg32.dll 5.00.3103.1000 236.77 KB (242,448 bytes)
12/7/1999 6:00:00 AM Microsoft Corporation
c:\winnt\system32\comdlg32.dll
msdart.dll 2.60.6526.0 144.27 KB (147,728 bytes) 9/13/2000 4:44:23
PM Microsoft Corporation c:\winnt\system32\msdart.dll
oledb32.dll 2.60.6526.0 448.27 KB (459,024 bytes) 9/13/2000 4:44:24
PM Microsoft Corporation c:\program files\common files\system\ole
db\oledb32.dll
msjint40.dll 4.00.2927.2 148.27 KB (151,824 bytes) 9/15/2000
3:02:03 PM Microsoft Corporation c:\winnt\system32\msjint40.dll
msjter40.dll 4.00.2927.2 52.27 KB (53,520 bytes) 9/15/2000 3:02:03
PM Microsoft Corporation c:\winnt\system32\msjter40.dll
```

## Appendix C – Tunable Parameters

---

mswstr10.dll 4.00.3829.2 600.27 KB (614,672 bytes) 9/15/2000  
3:02:01 PM Microsoft Corporation c:\winnt\system32\mswstr10.dll  
msjet40.dll 4.00.3714.7 1.43 MB (1,499,408 bytes) 9/15/2000 3:02:04  
PM Microsoft Corporation c:\winnt\system32\msjet40.dll  
msjetoledb40.dll 4.00.3714.0 340.27 KB (348,432 bytes) 9/15/2000  
3:02:03 PM Microsoft Corporation c:\winnt\system32\msjetoledb40.dll  
iasrad.dll 5.00.2139.1 94.27 KB (96,528 bytes) 12/7/1999 6:00:00 AM  
Microsoft Corporation c:\winnt\system32\iasrad.dll  
iassam.dll 5.00.2160.1 96.27 KB (98,576 bytes) 12/7/1999 6:00:00 AM  
Microsoft Corporation c:\winnt\system32\iassam.dll  
iasads.dll 5.00.2134.1 73.77 KB (75,536 bytes) 12/7/1999 6:00:00 AM  
Microsoft Corporation c:\winnt\system32\iasads.dll  
sens.dll 5.00.2163.1 36.77 KB (37,648 bytes) 12/7/1999 6:00:00 AM  
Microsoft Corporation c:\winnt\system32\sens.dll  
iaspolcy.dll 5.00.2134.1 25.27 KB (25,872 bytes) 12/7/1999 6:00:00  
AM Microsoft Corporation c:\winnt\system32\iaspolcy.dll  
iassvcs.dll 5.00.2160.1 58.77 KB (60,176 bytes) 12/7/1999 6:00:00 AM  
Microsoft Corporation c:\winnt\system32\iassvcs.dll  
iassdo.dll 5.00.2195.1163 262.27 KB (268,560 bytes) 9/15/2000  
3:02:13 PM Microsoft Corporation c:\winnt\system32\iassdo.dll  
ias.dll 5.00.2134.1 7.27 KB (7,440 bytes) 12/7/1999 6:00:00 AM  
Microsoft Corporation c:\winnt\system32\ias.dll  
es.dll 1999.9.3422.21 231.77 KB (237,328 bytes) 12/7/1999  
6:00:00 AM Microsoft Corporation c:\winnt\system32\es.dll  
mtxoci.dll 1999.9.3421.3 109.27 KB (111,888 bytes) 9/13/2000  
6:25:57 AM Microsoft Corporation c:\winnt\system32\mtxoci.dll  
resutils.dll 5.00.2195.1613 39.77 KB (40,720 bytes) 9/15/2000  
3:01:52 PM Microsoft Corporation c:\winnt\system32\resutils.dll  
clusapi.dll 5.00.2195.1613 54.27 KB (55,568 bytes) 9/15/2000 3:02:19  
PM Microsoft Corporation c:\winnt\system32\clusapi.dll  
msvcp50.dll 5.00.7051 552.50 KB (565,760 bytes) 12/7/1999 6:00:00  
AM Microsoft Corporation c:\winnt\system32\msvcp50.dll  
xolehlp.dll 1999.9.3421.3 17.27 KB (17,680 bytes) 9/13/2000 6:25:55  
AM Microsoft Corporation c:\winnt\system32\xolehlp.dll  
msdtclog.dll 1999.9.3421.3 89.77 KB (91,920 bytes) 9/13/2000  
6:25:55 AM Microsoft Corporation c:\winnt\system32\msdtclog.dll  
mtxclu.dll 1999.9.3421.3 50.27 KB (51,472 bytes) 12/7/1999 6:00:00  
AM Microsoft Corporation c:\winnt\system32\mtxclu.dll  
msdtcprx.dll 2000.2.3449.0 625.77 KB (640,784 bytes)  
9/15/2000 3:02:08 PM Microsoft Corporation  
c:\winnt\system32\msdtcprx.dll  
txfaux.dll 1999.9.3422.24 341.27 KB (349,456 bytes) 9/13/2000  
6:25:55 AM Microsoft Corporation c:\winnt\system32\txfaux.dll  
msdtctm.dll 2000.2.3449.0 1.07 MB (1,120,528 bytes) 9/15/2000  
3:02:07 PM Microsoft Corporation c:\winnt\system32\msdtctm.dll  
msdtc.exe 1999.9.3421.3 6.77 KB (6,928 bytes) 9/13/2000 6:25:55  
AM Microsoft Corporation c:\winnt\system32\msdtc.exe  
rasadhlp.dll 5.00.2168.1 7.27 KB (7,440 bytes) 12/7/1999 6:00:00  
AM Microsoft Corporation c:\winnt\system32\rasadhlp.dll  
winrnr.dll 5.00.2160.1 18.77 KB (19,216 bytes) 12/7/1999 6:00:00 AM  
Microsoft Corporation c:\winnt\system32\winrnr.dll  
rnr20.dll 5.00.2195.1207 35.77 KB (36,624 bytes) 9/15/2000 3:01:52  
PM Microsoft Corporation c:\winnt\system32\rnr20.dll  
wshtcpip.dll 5.00.2134.1 17.27 KB (17,680 bytes) 12/7/1999 6:00:00  
AM Microsoft Corporation c:\winnt\system32\wshtcpip.dll

## Appendix C – Tunable Parameters

---

dhcpcsvc.dll 5.00.2153.1 88.77 KB (90,896 bytes) 12/7/1999 6:00:00 AM  
Microsoft Corporation c:\winnt\system32\dhcpcsvc.dll  
tapi32.dll 5.00.2182.1 123.27 KB (126,224 bytes) 12/7/1999 6:00:00 AM  
Microsoft Corporation c:\winnt\system32\tapi32.dll  
rasman.dll 5.00.2188.1 54.77 KB (56,080 bytes) 12/7/1999 6:00:00 AM  
Microsoft Corporation c:\winnt\system32\rasman.dll  
rasapi32.dll 5.00.2188.1 189.77 KB (194,320 bytes) 12/7/1999 6:00:00 AM  
Microsoft Corporation c:\winnt\system32\rasapi32.dll  
iphlpapi.dll 5.00.2173.2 67.77 KB (69,392 bytes) 12/7/1999 6:00:00 AM  
Microsoft Corporation c:\winnt\system32\iphlpapi.dll  
msafd.dll 5.00.2195.1614 102.77 KB (105,232 bytes) 9/15/2000 3:02:08 PM  
Microsoft Corporation c:\winnt\system32\msafd.dll  
rpcss.dll 5.00.2195.1600 229.27 KB (234,768 bytes) 9/15/2000 3:01:51 PM  
Microsoft Corporation c:\winnt\system32\rpcss.dll  
svchost.exe 5.00.2134.1 7.77 KB (7,952 bytes) 12/7/1999 6:00:00 AM  
Microsoft Corporation c:\winnt\system32\svchost.exe  
vipl.dll 4.1.1 80.00 KB (81,920 bytes) 9/14/2000 5:08:42 PM  
Giganet Incorporated c:\winnt\system32\vipl.dll  
gnconmgr.exe 4.1.1 128.05 KB (131,119 bytes) 9/13/2000 3:45:58 PM  
Giganet Incorporated c:\winnt\system32\gnconmgr.exe  
scecli.dll 5.00.2191.1 105.27 KB (107,792 bytes) 12/7/1999 6:00:00 AM  
Microsoft Corporation c:\winnt\system32\scecli.dll  
atl.dll 3.00.8449 57.56 KB (58,938 bytes) 12/7/1999 6:00:00 AM  
Microsoft Corporation c:\winnt\system32\atl.dll  
certcli.dll 5.00.2175.1 132.27 KB (135,440 bytes) 12/7/1999 6:00:00 AM  
Microsoft Corporation c:\winnt\system32\certcli.dll  
mswsock.dll 5.00.2195.1207 62.77 KB (64,272 bytes) 9/15/2000 3:02:01 PM  
Microsoft Corporation c:\winnt\system32\mswsock.dll  
ntdsatq.dll 5.00.2195.1284 31.27 KB (32,016 bytes) 9/15/2000 3:02:00 PM  
Microsoft Corporation c:\winnt\system32\ntdsatq.dll  
ntdsa.dll 5.00.2195.1600 987.27 KB (1,010,960 bytes) 9/15/2000 3:02:00 PM  
Microsoft Corporation c:\winnt\system32\ntdsa.dll  
kdcsvc.dll 5.00.2195.1284 133.77 KB (136,976 bytes) 9/15/2000 3:02:09 PM  
Microsoft Corporation c:\winnt\system32\kdcsvc.dll  
sfmapi.dll 5.00.2134.1 38.77 KB (39,696 bytes) 12/7/1999 6:00:00 AM  
Microsoft Corporation c:\winnt\system32\sfmapi.dll  
rtutils.dll 5.00.2168.1 43.77 KB (44,816 bytes) 12/7/1999 6:00:00 AM  
Microsoft Corporation c:\winnt\system32\rtutils.dll  
adsldpc.dll 5.00.2195.1600 125.77 KB (128,784 bytes) 9/15/2000 3:02:22 PM  
Microsoft Corporation c:\winnt\system32\adsldpc.dll  
activeds.dll 5.00.2172.1 172.77 KB (176,912 bytes) 12/7/1999 6:00:00 AM  
Microsoft Corporation c:\winnt\system32\activeds.dll  
mprapi.dll 5.00.2181.1 79.27 KB (81,168 bytes) 12/7/1999 6:00:00 AM  
Microsoft Corporation c:\winnt\system32\mprapi.dll  
rassfm.dll 5.00.2195.1179 21.27 KB (21,776 bytes) 9/15/2000 3:01:52 PM  
Microsoft Corporation c:\winnt\system32\rassfm.dll  
mpr.dll 5.00.2195.1340 53.27 KB (54,544 bytes) 9/15/2000 3:02:09 PM  
Microsoft Corporation c:\winnt\system32\mpr.dll  
schannel.dll 5.00.2195.1163 137.27 KB (140,560 bytes) 7/21/2000 12:05:02 PM  
Microsoft Corporation c:\winnt\system32\schannel.dll  
netlogon.dll 5.00.2195.1600 348.27 KB (356,624 bytes) 9/15/2000 3:02:00 PM  
Microsoft Corporation c:\winnt\system32\netlogon.dll

## Appendix C – Tunable Parameters

---

```
msvl_0.dll 5.00.2195.1620 92.77 KB (94,992 bytes) 12/7/1999 6:00:00
AM Microsoft Corporation c:\winnt\system32\msvl_0.dll
kerberos.dll 5.00.2195.1378 197.77 KB (202,512 bytes)
9/15/2000 3:02:09 PM Microsoft Corporation
c:\winnt\system32\kerberos.dll
msprivs.dll 5.00.2154.1 41.50 KB (42,496 bytes) 12/7/1999 6:00:00 AM
Microsoft Corporation c:\winnt\system32\msprivs.dll
samsrv.dll 5.00.2195.1609 343.27 KB (351,504 bytes) 12/7/1999
6:00:00 AM Microsoft Corporation c:\winnt\system32\samsrv.dll
lsasrv.dll 5.00.2195.1620 475.27 KB (486,672 bytes) 12/7/1999
6:00:00 AM Microsoft Corporation c:\winnt\system32\lsasrv.dll
lsass.exe 5.00.2195.1620 32.77 KB (33,552 bytes) 12/7/1999 6:00:00
AM Microsoft Corporation c:\winnt\system32\lsass.exe
esent.dll 6.0.3940.4 1.08 MB (1,135,888 bytes) 9/15/2000 3:02:15
PM Microsoft Corporation c:\winnt\system32\esent.dll
ntlsapi.dll 5.00.2134.1 6.77 KB (6,928 bytes) 12/7/1999 6:00:00 AM
Microsoft Corporation c:\winnt\system32\ntlsapi.dll
wmicore.dll 5.00.2178.1 70.77 KB (72,464 bytes) 12/7/1999 6:00:00 AM
Microsoft Corporation c:\winnt\system32\wmicore.dll
xactsrv.dll 5.00.2134.1 90.27 KB (92,432 bytes) 12/7/1999 6:00:00 AM
Microsoft Corporation c:\winnt\system32\xactsrv.dll
browser.dll 5.00.2142.1 48.27 KB (49,424 bytes) 12/7/1999 6:00:00 AM
Microsoft Corporation c:\winnt\system32\browser.dll
seclogon.dll 5.00.2135.1 15.77 KB (16,144 bytes) 12/7/1999 6:00:00
AM Microsoft Corporation c:\winnt\system32\seclogon.dll
psbase.dll 5.00.2195.1600 111.77 KB (114,448 bytes) 9/15/2000
3:01:54 PM Microsoft Corporation c:\winnt\system32\psbase.dll
cryptsvc.dll 5.00.2181.1 61.77 KB (63,248 bytes) 12/7/1999 6:00:00
AM Microsoft Corporation c:\winnt\system32\cryptsvc.dll
cryptdll.dll 5.00.2135.1 41.27 KB (42,256 bytes) 12/7/1999 6:00:00
AM Microsoft Corporation c:\winnt\system32\cryptdll.dll
wkssvc.dll 5.00.2195.1175 95.27 KB (97,552 bytes) 12/7/1999 6:00:00
AM Microsoft Corporation c:\winnt\system32\wkssvc.dll
srvsvc.dll 5.00.2178.1 79.27 KB (81,168 bytes) 12/7/1999 6:00:00 AM
Microsoft Corporation c:\winnt\system32\srvsvc.dll
cfgmgr32.dll 5.00.2134.1 16.77 KB (17,168 bytes) 12/7/1999 6:00:00
AM Microsoft Corporation c:\winnt\system32\cfgmgr32.dll
dmsrvr.dll 2195.23.297.2 11.77 KB (12,048 bytes) 9/15/2000
3:02:16 PM VERITAS Software Corp. c:\winnt\system32\dmsrvr.dll
winsta.dll 5.00.2195.32 36.27 KB (37,136 bytes) 9/15/2000 3:01:46
PM Microsoft Corporation c:\winnt\system32\winsta.dll
icmp.dll 5.00.2134.1 7.27 KB (7,440 bytes) 12/7/1999 6:00:00 AM
Microsoft Corporation c:\winnt\system32\icmp.dll
lmhsvc.dll 5.00.2134.1 9.27 KB (9,488 bytes) 12/7/1999 6:00:00 AM
Microsoft Corporation c:\winnt\system32\lmhsvc.dll
eventlog.dll 5.00.2178.1 43.77 KB (44,816 bytes) 12/7/1999 6:00:00
AM Microsoft Corporation c:\winnt\system32\eventlog.dll
ntdsapi.dll 5.00.2160.1 56.27 KB (57,616 bytes) 12/7/1999 6:00:00 AM
Microsoft Corporation c:\winnt\system32\ntdsapi.dll
scesrv.dll 5.00.2188.1 225.77 KB (231,184 bytes) 12/7/1999 6:00:00
AM Microsoft Corporation c:\winnt\system32\scesrv.dll
umpnpgm.dll 5.00.2182.1 86.27 KB (88,336 bytes) 12/7/1999 6:00:00
AM Microsoft Corporation c:\winnt\system32\umpnpgm.dll
services.exe 5.00.2134.1 86.77 KB (88,848 bytes) 12/7/1999 6:00:00
AM Microsoft Corporation c:\winnt\system32\services.exe
```

## Appendix C – Tunable Parameters

---

clbcatq.dll 2000.2.3449.0 496.27 KB (508,176 bytes) 9/15/2000  
3:02:20 PM Microsoft Corporation c:\winnt\system32\clbcatq.dll  
oleaut32.dll 2.40.4514 600.27 KB (614,672 bytes) 12/7/1999  
6:00:00 AM Microsoft Corporation c:\winnt\system32\oleaut32.dll  
cscui.dll 5.00.2195.1387 227.27 KB (232,720 bytes) 9/15/2000  
3:02:18 PM Microsoft Corporation c:\winnt\system32\cscui.dll  
winspool.drv 5.00.2195.1340 109.77 KB (112,400 bytes)  
12/7/1999 6:00:00 AM Microsoft Corporation  
c:\winnt\system32\winspool.drv  
wincard.dll 5.00.2134.1 77.27 KB (79,120 bytes) 12/7/1999 6:00:00  
AM Microsoft Corporation c:\winnt\system32\wincard.dll  
wlnotify.dll 5.00.2195.1163 53.27 KB (54,544 bytes) 9/15/2000  
3:01:46 PM Microsoft Corporation c:\winnt\system32\wlnotify.dll  
csddl.dll 5.00.2195.1600 98.27 KB (100,624 bytes) 9/15/2000  
3:02:18 PM Microsoft Corporation c:\winnt\system32\csddl.dll  
lz32.dll 5.00.2134.1 9.77 KB (10,000 bytes) 12/7/1999 6:00:00 AM  
Microsoft Corporation c:\winnt\system32\lz32.dll  
version.dll 5.00.2134.1 15.77 KB (16,144 bytes) 12/7/1999 6:00:00 AM  
Microsoft Corporation c:\winnt\system32\version.dll  
rsabase.dll 5.00.2195.1391 129.27 KB (132,368 bytes) 7/21/2000  
12:05:02 PM Microsoft Corporation c:\winnt\system32\rsabase.dll  
mscat32.dll 5.131.2134.1 7.77 KB (7,952 bytes) 12/7/1999 6:00:00  
AM Microsoft Corporation c:\winnt\system32\mscat32.dll  
ole32.dll 5.00.2195.1607 965.27 KB (988,432 bytes) 9/15/2000  
3:01:56 PM Microsoft Corporation c:\winnt\system32\ole32.dll  
imagehlp.dll 5.00.2195.1 125.27 KB (128,272 bytes) 12/7/1999  
6:00:00 AM Microsoft Corporation c:\winnt\system32\imagehlp.dll  
msasn1.dll 5.00.2134.1 51.27 KB (52,496 bytes) 12/7/1999 6:00:00 AM  
Microsoft Corporation c:\winnt\system32\msasn1.dll  
crypt32.dll 5.131.2195.1340 464.77 KB (475,920 bytes) 9/15/2000  
3:02:18 PM Microsoft Corporation c:\winnt\system32\crypt32.dll  
wintrust.dll 5.131.2143.1 162.27 KB (166,160 bytes)  
12/7/1999 6:00:00 AM Microsoft Corporation  
c:\winnt\system32\wintrust.dll  
setupapi.dll 5.00.2195.1608 552.77 KB (566,032 bytes)  
12/7/1999 6:00:00 AM Microsoft Corporation  
c:\winnt\system32\setupapi.dll  
winmm.dll 5.00.2161.1 184.77 KB (189,200 bytes) 12/7/1999 6:00:00  
AM Microsoft Corporation c:\winnt\system32\winmm.dll  
comctl32.dll 5.81 537.77 KB (550,672 bytes) 12/7/1999 6:00:00  
AM Microsoft Corporation c:\winnt\system32\comctl32.dll  
shlwapi.dll 5.00.3103.1000 282.27 KB (289,040 bytes) 9/15/2000  
3:01:49 PM Microsoft Corporation c:\winnt\system32\shlwapi.dll  
shell32.dll 5.00.3103.1000 2.25 MB (2,358,032 bytes) 9/15/2000  
3:01:49 PM Microsoft Corporation c:\winnt\system32\shell32.dll  
msgina.dll 5.00.2195.1600 323.27 KB (331,024 bytes) 12/7/1999  
6:00:00 AM Microsoft Corporation c:\winnt\system32\msgina.dll  
wsock32.dll 5.00.2195.1207 21.27 KB (21,776 bytes) 9/15/2000 3:01:46  
PM Microsoft Corporation c:\winnt\system32\wsock32.dll  
dnsapi.dll 5.00.2195.1600 127.77 KB (130,832 bytes) 9/15/2000  
3:02:16 PM Microsoft Corporation c:\winnt\system32\dnsapi.dll  
wldap32.dll 5.00.2195.1175 155.27 KB (158,992 bytes) 9/15/2000  
3:01:46 PM Microsoft Corporation c:\winnt\system32\wldap32.dll  
ws2help.dll 5.00.2134.1 17.77 KB (18,192 bytes) 12/7/1999 6:00:00 AM  
Microsoft Corporation c:\winnt\system32\ws2help.dll

## Appendix C – Tunable Parameters

---

```

ws2_32.dll 5.00.2195.1340 68.77 KB (70,416 bytes) 9/15/2000 3:01:46
PM Microsoft Corporation c:\winnt\system32\ws2_32.dll
samlib.dll 5.00.2160.1 46.27 KB (47,376 bytes) 12/7/1999 6:00:00 AM
Microsoft Corporation c:\winnt\system32\samlib.dll
netrap.dll 5.00.2134.1 11.27 KB (11,536 bytes) 12/7/1999 6:00:00 AM
Microsoft Corporation c:\winnt\system32\netrap.dll
netapi32.dll 5.00.2195.1600 303.27 KB (310,544 bytes)
9/15/2000 3:02:01 PM Microsoft Corporation
c:\winnt\system32\netapi32.dll
profmap.dll 5.00.2181.1 29.27 KB (29,968 bytes) 12/7/1999 6:00:00 AM
Microsoft Corporation c:\winnt\system32\profmap.dll
secur32.dll 5.00.2195.1600 47.27 KB (48,400 bytes) 9/15/2000 3:01:50
PM Microsoft Corporation c:\winnt\system32\secur32.dll
sfc.dll 5.00.2195.1618 90.05 KB (92,216 bytes) 9/15/2000 3:01:50
PM Microsoft Corporation c:\winnt\system32\sfc.dll
nddeapi.dll 5.00.2137.1 15.27 KB (15,632 bytes) 12/7/1999 6:00:00 AM
Microsoft Corporation c:\winnt\system32\nddeapi.dll
userenv.dll 5.00.2195.1600 359.27 KB (367,888 bytes) 12/7/1999
6:00:00 AM Microsoft Corporation c:\winnt\system32\userenv.dll
user32.dll 5.00.2195.1600 392.77 KB (402,192 bytes) 12/7/1999
6:00:00 AM Microsoft Corporation c:\winnt\system32\user32.dll
gdi32.dll 5.00.2195.1340 228.77 KB (234,256 bytes) 12/7/1999
6:00:00 AM Microsoft Corporation c:\winnt\system32\gdi32.dll
rpcrt4.dll 5.00.2195.1615 436.27 KB (446,736 bytes) 9/15/2000
3:01:51 PM Microsoft Corporation c:\winnt\system32\rpcrt4.dll
advapi32.dll 5.00.2195.1600 349.27 KB (357,648 bytes)
12/7/1999 6:00:00 AM Microsoft Corporation
c:\winnt\system32\advapi32.dll
kernel32.dll 5.00.2195.1600 713.27 KB (730,384 bytes)
12/7/1999 6:00:00 AM Microsoft Corporation
c:\winnt\system32\kernel32.dll
msvcrt.dll 6.10.8637.0 288.09 KB (295,000 bytes) 12/7/1999 6:00:00
AM Microsoft Corporation c:\winnt\system32\msvcrt.dll
winlogon.exe 5.00.2195.1600 172.77 KB (176,912 bytes)
12/7/1999 6:00:00 AM Microsoft Corporation
c:\winnt\system32\winlogon.exe
sfcfiles.dll 5.00.2195.1 973.27 KB (996,624 bytes) 12/7/1999
6:00:00 AM Microsoft Corporation c:\winnt\system32\sfcfiles.dll
ntdll.dll 5.00.2195.1600 475.27 KB (486,672 bytes) 7/21/2000
12:05:02 PM Microsoft Corporation c:\winnt\system32\ntdll.dll
smss.exe 5.00.2195.31 44.27 KB (45,328 bytes) 12/7/1999 6:00:00
AM Microsoft Corporation c:\winnt\system32\smss.exe

```

### [Services]

Display Name	Name	State	Start	Mode	Service Type	Path	Error
Control	Start Name	Tag ID					
Alerter	Alerter	Stopped		Manual	Share Process		
	c:\winnt\system32\services.exe			Normal	LocalSystem	0	
Application Management Process	AppMgmt	Stopped		Manual	Share		
	c:\winnt\system32\services.exe			Normal	LocalSystem	0	
Computer Browser	Browser	Running		Auto	Share Process		
	c:\winnt\system32\services.exe			Normal	LocalSystem	0	

## Appendix C – Tunable Parameters

---

```

Indexing Service  cisvc Stopped      Manual      Share Process
c:\winnt\system32\cisvc.exe Normal      LocalSystem 0
ClipBook  ClipSrv      Stopped      Manual      Own Process
c:\winnt\system32\clipsrv.exe Normal      LocalSystem 0
Distributed File System Dfs      Stopped      Manual      Own Process
c:\winnt\system32\dfssvc.exe Normal      LocalSystem 0
DHCP Client Dhcp      Stopped      Manual      Share Process
c:\winnt\system32\services.exe Normal      LocalSystem 0
Logical Disk Manager Administrative Service dmadmin      Stopped
Manual      Share Process c:\winnt\system32\dmadmin.exe /com
Normal      LocalSystem 0
Logical Disk Manager dmsrvr      Running     Auto      Share Process
c:\winnt\system32\services.exe Normal      LocalSystem 0
DNS Client Dnscache      Stopped      Manual      Share Process
c:\winnt\system32\services.exe Normal      LocalSystem 0
Event Log Eventlog      Running     Auto      Share Process
c:\winnt\system32\services.exe Normal      LocalSystem 0
COM+ Event System EventSystem Running     Manual      Share Process
c:\winnt\system32\svchost.exe -k netsvcs Normal      LocalSystem
0
Fax Service Fax      Stopped      Manual      Own Process
c:\winnt\system32\faxsvc.exe Normal      LocalSystem 0
cLAN Connection Manager GniConMgr      Running     Auto      Own Process
c:\winnt\system32\gnconmgr.exe Normal      LocalSystem 0
Internet Authentication Service IAS      Running     Auto      Share
Process c:\winnt\system32\svchost.exe -k netsvcs Normal
LocalSystem 0
IIS Admin Service IISADMIN      Running     Auto      Share Process
c:\winnt\system32\inet_srv\inetinfo.exe Normal      LocalSystem
0
Intersite Messaging IsmServ      Stopped      Disabled     Own Process
c:\winnt\system32\ismserv.exe Normal      LocalSystem 0
Kerberos Key Distribution Center kdc      Stopped      Disabled     Share
Process c:\winnt\system32\lsass.exe Normal      LocalSystem 0
Server lanmanserver      Running     Auto      Share Process
c:\winnt\system32\services.exe Normal      LocalSystem 0
Workstation lanmanworkstation Running     Auto      Share Process
c:\winnt\system32\services.exe Normal      LocalSystem 0
License Logging Service LicenseService      Stopped      Manual      Own
Process c:\winnt\system32\llssrv.exe Normal      LocalSystem 0
TCP/IP NetBIOS Helper Service LmHosts      Running     Auto      Share
Process c:\winnt\system32\services.exe Normal      LocalSystem
0
Messenger Messenger      Stopped      Manual      Share Process
c:\winnt\system32\services.exe Normal      LocalSystem 0
NetMeeting Remote Desktop Sharing mnmsrv      Stopped      Manual
Own Process c:\winnt\system32\mnmsrv.exe Normal      LocalSystem
0
Distributed Transaction Coordinator MSDTC      Running     Auto      Own Process
c:\winnt\system32\msdtc.exe Normal      LocalSystem 0
Windows Installer MSIServer      Stopped      Manual      Share Process
c:\winnt\system32\msiexec.exe /v Normal      LocalSystem 0
Network DDE NetDDE      Stopped      Manual      Share Process
c:\winnt\system32\netdde.exe Normal      LocalSystem 0

```

## Appendix C – Tunable Parameters

---

```

Network DDE DSDM NetDDEdsdm Stopped Manual Share Process
  c:\winnt\system32\netdde.exe Normal LocalSystem 0
Net Logon Netlogon Stopped Manual Share Process
  c:\winnt\system32\lsass.exe Normal LocalSystem 0
Network Connections Netman Running Manual Share
Process c:\winnt\system32\svchost.exe -k netsvcs Normal
LocalSystem 0
File Replication NtFrs Stopped Manual Own Process
  c:\winnt\system32\ntfrs.exe Ignore LocalSystem 0
NT LM Security Support Provider NtLmSsp Stopped Manual
Share Process c:\winnt\system32\lsass.exe Normal
LocalSystem 0
Removable Storage NtmsSvc Stopped Manual Share Process
  c:\winnt\system32\svchost.exe -k netsvcs Normal LocalSystem
0
Plug and Play PlugPlay Running Auto Share Process
  c:\winnt\system32\services.exe Normal LocalSystem 0
IPSEC Policy Agent PolicyAgent Stopped Manual Share
Process c:\winnt\system32\lsass.exe Normal LocalSystem 0
Protected Storage ProtectedStorage Running Auto Share Process
  c:\winnt\system32\services.exe Normal LocalSystem 0
Remote Access Auto Connection Manager RasAuto Stopped
Manual Share Process c:\winnt\system32\svchost.exe -k
netsvcs Normal LocalSystem 0
Remote Access Connection Manager RasMan Stopped Manual
Share Process c:\winnt\system32\svchost.exe -k netsvcs
Normal LocalSystem 0
Routing and Remote Access RemoteAccess Stopped Disabled
Share Process c:\winnt\system32\svchost.exe -k netsvcs
Normal LocalSystem 0
Remote Registry Service RemoteRegistry Running Auto Own Process
  c:\winnt\system32\regsvc.exe Normal LocalSystem 0
Remote Procedure Call (RPC) Locator RpcLocator Stopped Manual
Own Process c:\winnt\system32\locator.exe Normal LocalSystem
0
Remote Procedure Call (RPC) RpcSs Running Auto Share Process
  c:\winnt\system32\svchost -k rpcss Normal LocalSystem 0
QoS RSVP RSVP Running Manual Own Process
  c:\winnt\system32\rsvp.exe -s Normal LocalSystem 0
Security Accounts Manager SamSs Running Auto Share Process
  c:\winnt\system32\lsass.exe Normal LocalSystem 0
Smart Card Helper SCardDrv Stopped Manual Share Process
  c:\winnt\system32\scardsvr.exe Ignore LocalSystem 0
Smart Card SCardSvr Stopped Manual Share Process
  c:\winnt\system32\scardsvr.exe Ignore LocalSystem 0
Task Scheduler Schedule Running Auto Share Process
  c:\winnt\system32\mstask.exe Normal LocalSystem 0
RunAs Service seclogon Running Auto Share Process
  c:\winnt\system32\services.exe Ignore LocalSystem 0
System Event Notification SENS Running Auto Share Process
  c:\winnt\system32\svchost.exe -k netsvcs Normal LocalSystem
0
Internet Connection Sharing SharedAccess Stopped Manual
Share Process c:\winnt\system32\svchost.exe -k netsvcs
Normal LocalSystem 0

```

## Appendix C – Tunable Parameters

---

Simple TCP/IP Services	SimpTcp	Running	Auto	Share Process
	c:\winnt\system32\tcpsvcs.exe	Normal	LocalSystem	0
Print Spooler	Spooler	Stopped	Manual	Own Process
	c:\winnt\system32\spoolsv.exe	Normal	LocalSystem	0
Performance Logs and Alerts	SysmonLog	Stopped	Manual	Own Process
	c:\winnt\system32\smlogsvc.exe	Normal	LocalSystem	0
Telephony	TapiSrv	Running	Manual	Share Process
	c:\winnt\system32\svchost.exe -k tapisrv	Normal	LocalSystem	0
Terminal Services	TermService	Stopped	Disabled	Own Process
	c:\winnt\system32\termsrv.exe	Normal	LocalSystem	0
Telnet	TlntSvr	Stopped	Manual	Own Process
	c:\winnt\system32\tlntsvr.exe	Normal	LocalSystem	0
Distributed Link Tracking Server	TrkSvr	Stopped	Manual	Share Process
	c:\winnt\system32\services.exe	Normal	LocalSystem	0
Distributed Link Tracking Client	TrkWks	Stopped	Manual	Share Process
	c:\winnt\system32\services.exe	Normal	LocalSystem	0
Uninterruptible Power Supply	UPS	Stopped	Manual	Own Process
	c:\winnt\system32\ups.exe	Normal	LocalSystem	0
Utility Manager	UtilMan	Stopped	Manual	Own Process
	c:\winnt\system32\utilman.exe	Normal	LocalSystem	0
Windows Time	W32Time	Stopped	Manual	Share Process
	c:\winnt\system32\services.exe	Normal	LocalSystem	0
World Wide Web Publishing Service	W3SVC	Running	Auto	Share Process
	c:\winnt\system32\inet_srv\inetinfo.exe	Normal	LocalSystem	0
Windows Management Instrumentation	WinMgmt	Running	Auto	Own Process
	c:\winnt\system32\wbem\winmgmt.exe	Ignore	LocalSystem	0
Windows Management Instrumentation Driver Extensions	Wmi	Running	Manual	Share Process
	c:\winnt\system32\services.exe	Normal	LocalSystem	0

[Program Groups]

Group Name	Name	User Name
Accessories	Default User:Accessories	Default User
Accessories\Accessibility	Default User:Accessories\Accessibility	Default User
Accessories\Entertainment	Default User:Accessories\Entertainment	Default User
Accessories\System Tools	Default User:Accessories\System Tools	Default User
Startup	Default User:Startup	Default User
Accessories All Users:Accessories	All Users	
Accessories\Accessibility	All Users:Accessories\Accessibility	All Users
Accessories\Communications	All Users:Accessories\Communications	All Users
Accessories\Entertainment	All Users:Accessories\Entertainment	All Users
Accessories\Games	All Users:Accessories\Games	All Users

## Appendix C – Tunable Parameters

---

Accessories\System Tools      All Users:Accessories\System Tools    All Users  
Administrative Tools      All Users:Administrative Tools      All Users  
GigaNet      All Users:GigaNet    All Users  
Microsoft SQL Server      All Users:Microsoft SQL Server      All Users  
MKS Toolkit    All Users:MKS Toolkit      All Users  
Startup      All Users:Startup    All Users  
Accessories CLIENT2\Administrator:Accessories    CLIENT2\Administrator  
Accessories\Accessibility  
    CLIENT2\Administrator:Accessories\Accessibility  
    CLIENT2\Administrator  
Accessories\Entertainment  
    CLIENT2\Administrator:Accessories\Entertainment  
    CLIENT2\Administrator  
Accessories\System Tools      CLIENT2\Administrator:Accessories\System  
Tools CLIENT2\Administrator  
Administrative Tools      CLIENT2\Administrator:Administrative Tools  
    CLIENT2\Administrator  
Startup      CLIENT2\Administrator:Startup    CLIENT2\Administrator

[Startup Programs]

Program	Command	User Name	Location
No startup program information			

[OLE Registration]

Object	Local Server
Sound (OLE2)	sndrec32.exe
Media Clip	mplay32.exe
Video Clip	mplay32.exe /avi
MIDI Sequence	mplay32.exe /mid
Sound	Not Available
Media Clip	Not Available
Image Document	"C:\Program Files\Windows NT\Accessories\ImageVue\KodakImg.exe"
WordPad Document	"%ProgramFiles%\Windows NT\Accessories\WORDPAD.EXE"
Windows Media Services DRM Storage object	Not Available
Bitmap Image	mspaint.exe

[Internet Explorer 5]

[ Following are sub-categories of this main category ]

[Summary]

Item	Value
Version	5.00.3103.1000
Build	53103.1000
Product ID	51876-OEM-0000007-00000
Application Path	C:\Program Files\Internet Explorer
Language	English (United States)
Active Printer	Not Available

Cipher Strength    56-bit

## Appendix C – Tunable Parameters

---

Content Advisor    Disabled  
IEAK Install        No

### [File Versions]

File	Version	Size	Date	Path	Company		
advapi32.dll	5.0.2195.1600	349 KB	7/21/2000	12:05:02 PM	C:\WINNT\system32	Microsoft Corporation	
advapi32.dll	5.0.2195.1600	349 KB	7/21/2000	12:05:02 PM		Microsoft Corporation	
advpack.dll	5.0.3103.1000	87 KB	7/21/2000	12:05:02 PM	C:\WINNT\system32	Microsoft Corporation	
advpack.dll	5.0.3103.1000	87 KB	7/21/2000	12:05:02 PM		Microsoft Corporation	
browseic.dll	5.0.3103.1000	35 KB	7/21/2000	12:05:02 PM	C:\WINNT\system32	Microsoft Corporation	
browseic.dll	5.0.3103.1000	35 KB	7/21/2000	12:05:02 PM		Microsoft Corporation	
browseui.dll	5.0.3103.1000	789 KB	7/21/2000	12:05:02 PM	C:\WINNT\system32	Microsoft Corporation	
browseui.dll	5.0.3103.1000	789 KB	7/21/2000	12:05:02 PM		Microsoft Corporation	
ckcnv.exe	5.0.2189.1	9 KB	12/7/1999	7:00:00 AM	C:\WINNT\system32	Microsoft Corporation	
ckcnv.exe	5.0.2189.1	9 KB	12/7/1999	7:00:00 AM		Microsoft Corporation	
comctl32.dll	5.81.3103.1000	538 KB	7/21/2000	12:05:02 PM	C:\WINNT\system32	Microsoft Corporation	
comctl32.dll	5.81.3103.1000	538 KB	7/21/2000	12:05:02 PM		Microsoft Corporation	
crypt32.dll	5.131.2195.1340	465 KB	7/21/2000	12:05:02 PM	C:\WINNT\system32	Microsoft Corporation	
crypt32.dll	5.131.2195.1340	465 KB	7/21/2000	12:05:02 PM		Microsoft Corporation	
ehnsig.dll	<File Missing>	Not Available	Not Available	Not Available			
iemigrat.dll	<File Missing>	Not Available	Not Available	Not Available			
iesetup.dll	5.0.3103.1000	57 KB	7/21/2000	12:05:02 PM	C:\WINNT\system32	Microsoft Corporation	
iesetup.dll	5.0.3103.1000	57 KB	7/21/2000	12:05:02 PM		Microsoft Corporation	
iexplore.exe	5.0.2920.0	59 KB	12/7/1999	7:00:00 AM	C:\Program Files\Internet Explorer	Microsoft Corporation	
imagehlp.dll	5.0.2195.1	125 KB	12/7/1999	7:00:00 AM	C:\WINNT\system32	Microsoft Corporation	
imagehlp.dll	5.0.2195.1	125 KB	12/7/1999	7:00:00 AM		Microsoft Corporation	
imghelp.dll	<File Missing>	Not Available	Not Available	Not Available			
inseng.dll	5.0.3103.1000	72 KB	7/21/2000	12:05:02 PM	C:\WINNT\system32	Microsoft Corporation	
inseng.dll	5.0.3103.1000	72 KB	7/21/2000	12:05:02 PM		Microsoft Corporation	

## Appendix C – Tunable Parameters

---

```

jobexec.dll 5.0.0.1      47 KB 12/7/1999 7:00:00 AM    C:\WINNT\system32
    Microsoft Corporation
jobexec.dll 5.0.0.1      47 KB 12/7/1999 7:00:00 AM    .      Microsoft
Corporation
jscript.dll 5.1.0.5010   476 KB      7/21/2000 12:05:02 PM
    C:\WINNT\system32 Microsoft Corporation
jscript.dll 5.1.0.5010   476 KB      7/21/2000 12:05:02 PM    .
    Microsoft Corporation
jsproxy.dll 5.0.2920.0   13 KB 12/7/1999 7:00:00 AM    C:\WINNT\system32
    Microsoft Corporation
jsproxy.dll 5.0.2920.0   13 KB 12/7/1999 7:00:00 AM    .      Microsoft
Corporation
msaahtml.dll <File Missing>      Not Available      Not Available
    Not Available      Not Available
mshtml.dll 5.0.3103.1000      2292 KB      7/21/2000 12:05:02 PM
    C:\WINNT\system32 Microsoft Corporation
mshtml.dll 5.0.3103.1000      2292 KB      7/21/2000 12:05:02 PM    .
    Microsoft Corporation
msjava.dll 5.0.3310.0   922 KB      7/21/2000 12:05:02 PM
    C:\WINNT\system32 Microsoft Corporation
msjava.dll 5.0.3310.0   922 KB      7/21/2000 12:05:02 PM    .
    Microsoft Corporation
msoss.dll <File Missing>      Not Available      Not Available      Not
Available      Not Available
msxml.dll 8.0.5226.0   506 KB      7/21/2000 12:05:02 PM
    C:\WINNT\system32 Microsoft Corporation
msxml.dll 8.0.5226.0   506 KB      7/21/2000 12:05:02 PM    .
    Microsoft Corporation
occache.dll 5.0.3103.1000      86 KB 7/21/2000 12:05:02 PM
    C:\WINNT\system32 Microsoft Corporation
occache.dll 5.0.3103.1000      86 KB 7/21/2000 12:05:02 PM    .
    Microsoft Corporation
ole32.dll 5.0.2195.1607      965 KB      7/21/2000 12:05:02 PM
    C:\WINNT\system32 Microsoft Corporation
ole32.dll 5.0.2195.1607      965 KB      7/21/2000 12:05:02 PM    .
    Microsoft Corporation
oleaut32.dll 2.40.4514.1 600 KB      7/21/2000 12:05:02 PM
    C:\WINNT\system32 Microsoft Corporation
oleaut32.dll 2.40.4514.1 600 KB      7/21/2000 12:05:02 PM    .
    Microsoft Corporation
olepro32.dll 5.0.4514.1 160 KB      7/21/2000 12:05:02 PM
    C:\WINNT\system32 Microsoft Corporation
olepro32.dll 5.0.4514.1 160 KB      7/21/2000 12:05:02 PM    .
    Microsoft Corporation
rsabase.dll 5.0.2195.1391      129 KB      7/21/2000 12:05:02 PM
    C:\WINNT\system32 Microsoft Corporation
rsabase.dll 5.0.2195.1391      129 KB      7/21/2000 12:05:02 PM    .
    Microsoft Corporation
rsaenh.dll <File Missing>      Not Available      Not Available      Not
Available      Not Available
rsapi32.dll <File Missing>      Not Available      Not Available      Not
Available      Not Available
rsasig.dll <File Missing>      Not Available      Not Available      Not
Available      Not Available

```

## Appendix C – Tunable Parameters

---

```
schannel.dll      5.0.2195.0  137 KB      7/21/2000 12:05:02 PM
                  C:\WINNT\system32 Microsoft Corporation
schannel.dll      5.0.2195.0  137 KB      7/21/2000 12:05:02 PM .
                  Microsoft Corporation
shdoc401.dll      <File Missing>  Not Available  Not Available
                  Not Available      Not Available
shdocvw.dll 5.0.3103.1000  1078 KB      7/21/2000 12:05:02 PM
                  C:\WINNT\system32 Microsoft Corporation
shdocvw.dll 5.0.3103.1000  1078 KB      7/21/2000 12:05:02 PM .
                  Microsoft Corporation
shell32.dll 5.0.3103.1000  2303 KB      7/21/2000 12:05:02 PM
                  C:\WINNT\system32 Microsoft Corporation
shell32.dll 5.0.3103.1000  2303 KB      7/21/2000 12:05:02 PM .
                  Microsoft Corporation
shlwapi.dll 5.0.3103.1000  282 KB      7/21/2000 12:05:02 PM
                  C:\WINNT\system32 Microsoft Corporation
shlwapi.dll 5.0.3103.1000  282 KB      7/21/2000 12:05:02 PM .
                  Microsoft Corporation
url.dll      5.0.2920.0  82 KB 12/7/1999 7:00:00 AM  C:\WINNT\system32
                  Microsoft Corporation
url.dll      5.0.2920.0  82 KB 12/7/1999 7:00:00 AM  .      Microsoft
Corporation
urlmon.dll 5.0.3103.1000  441 KB      7/21/2000 12:05:02 PM
                  C:\WINNT\system32 Microsoft Corporation
urlmon.dll 5.0.3103.1000  441 KB      7/21/2000 12:05:02 PM .
                  Microsoft Corporation
vbscript.dll 5.1.0.5010  428 KB      7/21/2000 12:05:02 PM
                  C:\WINNT\system32 Microsoft Corporation
vbscript.dll 5.1.0.5010  428 KB      7/21/2000 12:05:02 PM .
                  Microsoft Corporation
webcheck.dll 5.0.3103.1000  252 KB      7/21/2000 12:05:02 PM
                  C:\WINNT\system32 Microsoft Corporation
webcheck.dll 5.0.3103.1000  252 KB      7/21/2000 12:05:02 PM
                  .      Microsoft Corporation
win.com      5.0.2134.1  24 KB 12/7/1999 7:00:00 AM  C:\WINNT\system32
                  Microsoft Corporation
win.com      5.0.2134.1  24 KB 12/7/1999 7:00:00 AM  .      Microsoft
Corporation
wininet.dll 5.0.3103.1000  457 KB      7/21/2000 12:05:02 PM
                  C:\WINNT\system32 Microsoft Corporation
wininet.dll 5.0.3103.1000  457 KB      7/21/2000 12:05:02 PM .
                  Microsoft Corporation
winsock.dll 3.10.0.103  3 KB 12/7/1999 7:00:00 AM  C:\WINNT\system32
                  Microsoft Corporation
winsock.dll 3.10.0.103  3 KB 12/7/1999 7:00:00 AM  .      Microsoft
Corporation
wintrust.dll 5.131.2143.1  162 KB      12/7/1999 7:00:00 AM
                  C:\WINNT\system32 Microsoft Corporation
wintrust.dll 5.131.2143.1  162 KB      12/7/1999 7:00:00 AM
                  .      Microsoft Corporation
wsock.vxd     <File Missing>  Not Available  Not Available  Not
Available      Not Available
wsock32.dll 5.0.2195.1207  21 KB 7/21/2000 12:05:02 PM
                  C:\WINNT\system32 Microsoft Corporation
```

## Appendix C – Tunable Parameters

---

wsock32.dll 5.0.2195.1207 21 KB 7/21/2000 12:05:02 PM .  
Microsoft Corporation  
wsock32n.dll <File Missing> Not Available Not Available  
Not Available Not Available

### [Connectivity]

Item	Value
Connection Preference	Never dial
EnableHttp1.1	1
ProxyHttp1.1	0

### LAN Settings

AutoConfigProxy wininet.dll  
AutoProxyDetectMode Enabled  
AutoConfigURL  
Proxy Disabled  
ProxyServer  
ProxyOverride

### [Cache]

[ Following are sub-categories of this main category ]

### [Summary]

Item	Value
Page Refresh Type	Automatic
Temporary Internet Files Folder	C:\Documents and Settings\Administrator\Local Settings\Temporary Internet Files
Total Disk Space	4345 MB
Available Disk Space	1471 MB
Maximum Cache Size	135 MB
Available Cache Size	136 MB

### [List of Objects]

Program File	Status	CodeBase
No cached object information available		

### [Content]

[ Following are sub-categories of this main category ]

### [Summary]

Item	Value
Content Advisor	Disabled

### [Personal Certificates]

Issued To	Issued By	Validity	Signature Algorithm
Administrator	Administrator	9/13/2000 to 8/20/2100	sha1RSA

## Appendix C – Tunable Parameters

---

[Other People Certificates]

Issued To	Issued By	Validity	Signature Algorithm
No other people certificate information available			

[Publishers]

Name

No publisher information available

[Security]

Zone Security Level

Local intranet	Medium-low
----------------	------------

Trusted sites	Low
---------------	-----

Internet	Medium
----------	--------

Restricted sites	High
------------------	------

# Appendix C – Tunable Parameters

---

## *RTE Input Parameters*

### BenchCraft Configuration File

Profile: 2432\_32\_4\_01  
File Path: C:\benchcrf\2432\_32\_4\_01.pro  
Version: 1.0.1

Number of Engines: 8  
Name: DRIVER2A  
Description: RTE2A  
Directory: c:\tpcclog\rte2a.log  
Machine: RTE2A  
Parameter Set: PARAM2  
Index: 0  
Seed: 98176  
Configured Users: 3040  
Pipe Name: DRIVER43501360  
Connect Rate: 2000  
Start Rate: 0  
CLIENT\_NURAND: 208  
CPU: 0

Name: DRIVER2B  
Description: RTE2B  
Directory: c:\tpcclog\rte2b.log  
Machine: RTE2B  
Parameter Set: PARAM2  
Index: 100000000  
Seed: 98176  
Configured Users: 3040  
Pipe Name: DRIVER40641161  
Connect Rate: 2000  
Start Rate: 0  
CLIENT\_NURAND: 208  
CPU: 0

Name: DRIVER3A  
Description: RTE3A  
Directory: c:\tpcclog\rte3a.log  
Machine: RTE3A  
Parameter Set: PARAM2  
Index: 200000000  
Seed: 98176  
Configured Users: 3040  
Pipe Name: DRIVER371721555  
Connect Rate: 2000  
Start Rate: 0  
CLIENT\_NURAND: 208  
CPU: 0

## Appendix C – Tunable Parameters

---

Name: DRIVER3B  
Description: RTE3B  
Directory: c:\tpcclog\rte3b.log  
Machine: RTE3B  
Parameter Set: PARAM2  
Index: 30000000  
Seed: 98176  
Configured Users: 3040  
Pipe Name: DRIVER341837462  
Connect Rate: 2000  
Start Rate: 0  
CLIENT\_NURAND: 208  
CPU: 0

Name: DRIVER4A  
Description: RTE4A  
Directory: c:\tpcclog\rte4a.log  
Machine: RTE4A  
Parameter Set: PARAM2  
Index: 40000000  
Seed: 98176  
Configured Users: 3040  
Pipe Name: DRIVER311984373  
Connect Rate: 2000  
Start Rate: 0  
CLIENT\_NURAND: 208  
CPU: 0

Name: DRIVER4B  
Description: RTE4B  
Directory: c:\tpcclog\rte4b.log  
Machine: RTE4B  
Parameter Set: PARAM2  
Index: 50000000  
Seed: 98176  
Configured Users: 3040  
Pipe Name: DRIVER282107740  
Connect Rate: 2000  
Start Rate: 0  
CLIENT\_NURAND: 208  
CPU: 0

Name: DRIVER5A  
Description: RTE5A  
Directory: c:\tpcclog\rte5a.log  
Machine: RTE5A  
Parameter Set: PARAM2  
Index: 60000000  
Seed: 98176  
Configured Users: 3040  
Pipe Name: DRIVER252204459  
Connect Rate: 2000  
Start Rate: 0  
CLIENT\_NURAND: 208  
CPU: 0

## Appendix C – Tunable Parameters

---

Name: DRIVER5B  
Description: RTE5B  
Directory: c:\tpcclog\rte5b.log  
Machine: RTE5B  
Parameter Set: PARAM2  
Index: 70000000  
Seed: 98176  
Configured Users: 3040  
Pipe Name: DRIVER222420160  
Connect Rate: 2000  
Start Rate: 0  
CLIENT\_NURAND: 208  
CPU: 0

Number of User groups: 32

Driver Engine: DRIVER2A  
IIS Server: CLIENT2\_1  
SQL Server: PE6400\_01  
User: sa  
Protocol: Html  
w\_id Range: 1 - 76  
w\_id Max Warehouse: 2432  
Scale: Normal  
User Count: 760  
District id: 1  
Scale Down: No

Driver Engine: DRIVER2A  
IIS Server: CLIENT3\_1  
SQL Server: PE6400\_01  
User: sa  
Protocol: Html  
w\_id Range: 77 - 152  
w\_id Max Warehouse: 2432  
Scale: Normal  
User Count: 760  
District id: 1  
Scale Down: No

Driver Engine: DRIVER2A  
IIS Server: CLIENT4\_1  
SQL Server: PE6400\_01  
User: sa  
Protocol: Html  
w\_id Range: 153 - 228  
w\_id Max Warehouse: 2432  
Scale: Normal  
User Count: 760  
District id: 1  
Scale Down: No

Driver Engine: DRIVER2A  
IIS Server: CLIENT5\_1

## Appendix C – Tunable Parameters

---

SQL Server: PE6400\_01  
User: sa  
Protocol: Html  
w\_id Range: 229 - 304  
w\_id Max Warehouse: 2432  
Scale: Normal  
User Count: 760  
District id: 1  
Scale Down: No

Driver Engine: DRIVER2B  
IIS Server: CLIENT2\_1  
SQL Server: PE6400\_01  
User: sa  
Protocol: Html  
w\_id Range: 305 - 380  
w\_id Max Warehouse: 2432  
Scale: Normal  
User Count: 760  
District id: 1  
Scale Down: No

Driver Engine: DRIVER2B  
IIS Server: CLIENT3\_1  
SQL Server: PE6400\_01  
User: sa  
Protocol: Html  
w\_id Range: 381 - 456  
w\_id Max Warehouse: 2432  
Scale: Normal  
User Count: 760  
District id: 1  
Scale Down: No

Driver Engine: DRIVER2B  
IIS Server: CLIENT4\_1  
SQL Server: PE6400\_01  
User: sa  
Protocol: Html  
w\_id Range: 457 - 532  
w\_id Max Warehouse: 2432  
Scale: Normal  
User Count: 760  
District id: 1  
Scale Down: No

Driver Engine: DRIVER2B  
IIS Server: CLIENT5\_1  
SQL Server: PE6400\_01  
User: sa  
Protocol: Html  
w\_id Range: 533 - 608  
w\_id Max Warehouse: 2432  
Scale: Normal  
User Count: 760

## Appendix C – Tunable Parameters

---

District id: 1  
Scale Down: No

Driver Engine: DRIVER3A  
IIS Server: CLIENT2\_1  
SQL Server: PE6400\_01  
User: sa  
Protocol: Html  
w\_id Range: 609 - 684  
w\_id Max Warehouse: 2432  
Scale: Normal  
User Count: 760  
District id: 1  
Scale Down: No

Driver Engine: DRIVER3A  
IIS Server: CLIENT3\_1  
SQL Server: PE6400\_01  
User: sa  
Protocol: Html  
w\_id Range: 685 - 760  
w\_id Max Warehouse: 2432  
Scale: Normal  
User Count: 760  
District id: 1  
Scale Down: No

Driver Engine: DRIVER3A  
IIS Server: CLIENT4\_1  
SQL Server: PE6400\_01  
User: sa  
Protocol: Html  
w\_id Range: 761 - 836  
w\_id Max Warehouse: 2432  
Scale: Normal  
User Count: 760  
District id: 1  
Scale Down: No

Driver Engine: DRIVER3A  
IIS Server: CLIENT5\_1  
SQL Server: PE6400\_01  
User: sa  
Protocol: Html  
w\_id Range: 837 - 912  
w\_id Max Warehouse: 2432  
Scale: Normal  
User Count: 760  
District id: 1  
Scale Down: No

Driver Engine: DRIVER3B  
IIS Server: CLIENT2\_1  
SQL Server: PE6400\_01  
User: sa

## Appendix C – Tunable Parameters

---

Protocol: Html  
w\_id Range: 913 - 988  
w\_id Max Warehouse: 2432  
Scale: Normal  
User Count: 760  
District id: 1  
Scale Down: No

Driver Engine: DRIVER3B  
IIS Server: CLIENT3\_1  
SQL Server: PE6400\_01  
User: sa  
Protocol: Html  
w\_id Range: 989 - 1064  
w\_id Max Warehouse: 2432  
Scale: Normal  
User Count: 760  
District id: 1  
Scale Down: No

Driver Engine: DRIVER3B  
IIS Server: CLIENT4\_1  
SQL Server: PE6400\_01  
User: sa  
Protocol: Html  
w\_id Range: 1065 - 1140  
w\_id Max Warehouse: 2432  
Scale: Normal  
User Count: 760  
District id: 1  
Scale Down: No

Driver Engine: DRIVER3B  
IIS Server: CLIENT5\_1  
SQL Server: PE6400\_01  
User: sa  
Protocol: Html  
w\_id Range: 1141 - 1216  
w\_id Max Warehouse: 2432  
Scale: Normal  
User Count: 760  
District id: 1  
Scale Down: No

Driver Engine: DRIVER4A  
IIS Server: client2\_1  
SQL Server: pe6400\_01  
User: sa  
Protocol: Html  
w\_id Range: 1217 - 1292  
w\_id Max Warehouse: 2432  
Scale: Normal  
User Count: 760  
District id: 1  
Scale Down: No

## Appendix C – Tunable Parameters

---

Driver Engine: DRIVER4A  
IIS Server: client3\_1  
SQL Server: pe6400\_01  
User: sa  
Protocol: Html  
w\_id Range: 1293 - 1368  
w\_id Max Warehouse: 2432  
Scale: Normal  
User Count: 760  
District id: 1  
Scale Down: No

Driver Engine: DRIVER4A  
IIS Server: client4\_1  
SQL Server: pe6400\_01  
User: sa  
Protocol: Html  
w\_id Range: 1369 - 1444  
w\_id Max Warehouse: 2432  
Scale: Normal  
User Count: 760  
District id: 1  
Scale Down: No

Driver Engine: DRIVER4A  
IIS Server: client5\_1  
SQL Server: pe6400\_01  
User: sa  
Protocol: Html  
w\_id Range: 1445 - 1520  
w\_id Max Warehouse: 2432  
Scale: Normal  
User Count: 760  
District id: 1  
Scale Down: No

Driver Engine: DRIVER4B  
IIS Server: CLIENT2\_1  
SQL Server: PE6400\_01  
User: sa  
Protocol: Html  
w\_id Range: 1521 - 1596  
w\_id Max Warehouse: 2432  
Scale: Normal  
User Count: 760  
District id: 1  
Scale Down: No

Driver Engine: DRIVER4B  
IIS Server: client3\_1  
SQL Server: pe6400\_01  
User: sa  
Protocol: Html  
w\_id Range: 1597 - 1672

## Appendix C – Tunable Parameters

---

w\_id Max Warehouse: 2432  
Scale: Normal  
User Count: 760  
District id: 1  
Scale Down: No

Driver Engine: DRIVER4B  
IIS Server: CLIENT4\_1  
SQL Server: PE6400\_01  
User: sa  
Protocol: Html  
w\_id Range: 1673 - 1748  
w\_id Max Warehouse: 2432  
Scale: Normal  
User Count: 760  
District id: 1  
Scale Down: No

Driver Engine: DRIVER4B  
IIS Server: CLIENT5\_1  
SQL Server: PE6400\_01  
User: sa  
Protocol: Html  
w\_id Range: 1749 - 1824  
w\_id Max Warehouse: 2432  
Scale: Normal  
User Count: 760  
District id: 1  
Scale Down: No

Driver Engine: DRIVER5A  
IIS Server: CLIENT2\_1  
SQL Server: PE6400\_01  
User: sa  
Protocol: Html  
w\_id Range: 1825 - 1900  
w\_id Max Warehouse: 2432  
Scale: Normal  
User Count: 760  
District id: 1  
Scale Down: No

Driver Engine: DRIVER5A  
IIS Server: CLIENT3\_1  
SQL Server: PE6400\_01  
User: sa  
Protocol: Html  
w\_id Range: 1901 - 1976  
w\_id Max Warehouse: 2432  
Scale: Normal  
User Count: 760  
District id: 1  
Scale Down: No

Driver Engine: DRIVER5A

---

## Appendix C – Tunable Parameters

---

IIS Server: CLIENT4\_1  
SQL Server: PE6400\_01  
User: sa  
Protocol: Html  
w\_id Range: 1977 - 2052  
w\_id Max Warehouse: 2432  
Scale: Normal  
User Count: 760  
District id: 1  
Scale Down: No

Driver Engine: DRIVER5A  
IIS Server: CLIENT5\_1  
SQL Server: PE6400\_01  
User: sa  
Protocol: Html  
w\_id Range: 2053 - 2128  
w\_id Max Warehouse: 2432  
Scale: Normal  
User Count: 760  
District id: 1  
Scale Down: No

Driver Engine: DRIVER5B  
IIS Server: CLIENT2\_1  
SQL Server: PE6400\_01  
User: sa  
Protocol: Html  
w\_id Range: 2129 - 2204  
w\_id Max Warehouse: 2432  
Scale: Normal  
User Count: 760  
District id: 1  
Scale Down: No

Driver Engine: DRIVER5B  
IIS Server: CLIENT3\_1  
SQL Server: PE6400\_01  
User: sa  
Protocol: Html  
w\_id Range: 2205 - 2280  
w\_id Max Warehouse: 2432  
Scale: Normal  
User Count: 760  
District id: 1  
Scale Down: No

Driver Engine: DRIVER5B  
IIS Server: CLIENT4\_1  
SQL Server: PE6400\_01  
User: sa  
Protocol: Html  
w\_id Range: 2281 - 2356  
w\_id Max Warehouse: 2432  
Scale: Normal

# Appendix C – Tunable Parameters

---

User Count: 760  
District id: 1  
Scale Down: No

Driver Engine: DRIVER5B  
IIS Server: CLIENT5\_1  
SQL Server: PE6400\_01  
User: sa  
Protocol: Html  
w\_id Range: 2357 - 2432  
w\_id Max Warehouse: 2432  
Scale: Normal  
User Count: 760  
District id: 1  
Scale Down: No

Number of Parameter Sets: 6

80 run

## New Parameter Set

	Txn Weight	Think Time	Key Time	RT Delay	RT Fence	Menu Delay	
New Order	44.86	18.00	18.00	18.02	0.10	5.00	0.10
Payment	43.05	18.00	3.02	0.10	5.00	0.10	
Delivery	4.03	13.00	2.02	0.10	5.00	0.10	
Stock Level	4.03	13.00	2.02	0.10	20.00	0.10	
Order Status	4.03	8.00	2.02	0.10	5.00	0.10	

50 run2

## New Parameter Set

	Txn Weight	Think Time	Key Time	RT Delay	RT Fence	Menu Delay	
New Order	44.86	32.00	18.02	0.10	5.00	0.10	
Payment	43.05	32.00	3.02	0.10	5.00	0.10	
Delivery	4.03	17.00	2.02	0.10	5.00	0.10	
Stock Level	4.03	17.00	2.02	0.10	20.00	0.10	
Order Status	4.03	27.00	2.02	0.10	5.00	0.10	

PARAM3

## New Parameter Set

	Txn Weight	Think Time	Key Time	RT Delay	RT Fence	Menu Delay	
New Order	44.86	12.04	18.02	0.10	5.00	0.10	
Payment	43.05	12.04	3.02	0.10	5.00	0.10	
Delivery	4.03	5.04	2.02	0.10	5.00	0.10	
Stock Level	4.03	5.04	2.02	0.10	20.00	0.10	
Order Status	4.03	10.04	2.02	0.10	5.00	0.10	

PARAM2

Slightly tweaked parameter set

	Txn Weight	Think Time	Key Time	RT Delay	RT Fence	Menu Delay	
New Order	44.84	12.04	18.02	0.10	5.00	0.10	
Payment	43.04	12.04	3.02	0.10	5.00	0.10	

## Appendix C – Tunable Parameters

---

Delivery	4.04	5.04	2.02	0.10	5.00	0.10
Stock Level	4.04	5.04	2.02	0.10	20.00	0.10
Order Status	4.04	10.04	2.02	0.10	5.00	0.10

~Default

Default Parameter Set

	Txn Weight	Think Time	Key Time	RT Delay	RT Fence	Menu Delay	
New Order	10.00	12.05	18.01	0.10	5.00	0.10	
Payment	10.00	12.05	3.01	0.10	5.00	0.10	
Delivery	1.00	5.05	2.01	0.10	5.00	0.10	
Stock Level	1.00	5.05	2.01	0.10	20.00	0.10	
Order Status	1.00	10.05	2.01	0.10	5.00	0.10	

50 run

New Parameter Set

	Txn Weight	Think Time	Key Time	RT Delay	RT Fence	Menu Delay	
New Order	44.86	30.00	18.02	0.10	5.00	0.10	
Payment	43.05	30.00	3.02	0.10	5.00	0.10	
Delivery	4.03	15.00	2.02	0.10	5.00	0.10	
Stock Level	4.03	15.00	2.02	0.10	20.00	0.10	
Order Status	4.03	25.00	2.02	0.10	5.00	0.10	

# Appendix D - Disk Storage

## Appendix D – Disk Storage

### 60 Day Space

TPC-C 60 Day Space Requirements						
Warehouses	2,450				TpmC	30250
Table	Rows	Data KB	Index KB	Extra 5% KB	8hr Space	Total Space KB
Warehouse	2,450	264	32	15		311
District	24,500	2,728	32	138		2898
Customer	73,500,000	53,454,552	3,187,504	2,832,103		59474159
History	73,500,000	4,333,344	80		856,072	4333424
NewOrder	22,050,000	348,624	824			349448
Orders	73,500,000	2,252,880	1,024,480		647,446	3277360
OrderLine	600,000,886	45,937,448	97,256		9,094,203	46034704
Item	100,000	9,528	48	479		10055
Stock	245,000,000	78,400,008	146,568	3,927,329		82473905
<b>Total</b>		184,739,376	4,456,824	6,760,063	10,597,721	195,956,263
<b>MB</b>	10,349.34					
<b>MB</b>						
Dynamic Space	51,293	Sum of Data for Order, Orderline and History				
Static Space	140,071	Sum of Data+Index+5%-Dynamic Space				
Free Space	na	Total Allocated Spac - ( Dynamic + Static Space)				
Daily Growth	10,133	(Dynamic Space/(W*62.5))*tpmc				
Daily Spread	-	(Free Space -1.5*Daily Growth) Zero Assumed				
60 Day Space MB	748,046		18 GB Drive	16.756	GB	603
<b>60 Day Space GB</b>	<b>730.51</b>	<b>GB</b>	9 GB Drive	8.470	GB	35.9871091
			36 GB Drive	33.512	GB	
Log Size	43,603	MB				
KB Per New Order	5.2349	KB				
8 hr log MB	74,229	MB				
<b>8 hr log GB</b>	<b>72.4891</b>	<b>GB</b>				
<b>Space Usage</b>	<b>GB Needed</b>	<b>Disks Measured</b>	<b>GB Priced</b>		<b>Disks Needed</b>	
60 Day Space DB	730.51	108	1,809.65	18GB		
		0	0.00	9GB		
		0	0.00	36GB		
Total DB		<b>108.00</b>	<b>1,809.65</b>	<b>GB</b>		
8-hr log + mirror	144.98	10	167.56	GB	10.00	
OS, Swap	3	1	8.470	GB		

## Appendix D - Disk Storage

---

<b>Total Storage</b>	<b>878.49</b>	<b>GB</b>	<b>1,985.68</b>	<b>GB</b>		
Log Space OK						
Total Space OK		-130.71857	-66.07701			
		9GB	18GB			

**Appendix E - Price Quotations**

## Mylex ExtremeRAID 2000 Quotation

<b>To: Nicholas Wakou - Dell</b>	<b>From: Bruce Foster</b> <b>Phone: 510/608-2328</b> <b>Fax: 510/745-8016</b> <b>Email: bfoster1@ibm.us.com</b>
<b>Company: Dell Computer – Enterprise Performance Group</b>	<b>Date: 08/13/01</b>
<b>RE: Mylex ExtremeRAID 2000 Price quote</b>	<b>Total Pages: 1</b>

Dear Mr. Wakou,

Mylex is pleased to submit the following quotation for ExtremeRAID 2000 controller:

=====

<u>Mylex P/n/</u>	<u>Description</u>	<u>Reseller Suggested price</u>
-------------------	--------------------	---------------------------------

EXtremeRAID 2000, PCI RAID Ultra 160/mSCSI 4 Channel RAID controller:

E2000-4-32NB [4 external +2 internal chnl, 32MB cache, no BBU]	\$1842
--	--------

=====

Notes: Above price is based on FOB, ex-factory, Fremont, California and firm for 90 days.

Lead time: 45 days ARO

Product is covered by a 5 year warranty.

Failed product will be repaired or replaced within 7 days.

**Bruce Foster - Director, Strategic Sales**

Cc: Steve Page – Director PCI Marketing  
34551 Ardenwood Blvd.  
Fremont, CA 94555-3607  
Tel: 510.796-6100  
Sales Fax: 510.745-8016  
www.mylex.com

## Appendix E - Price Quotations

---

Microsoft Corporation  
One Microsoft Way  
Redmond, WA 98052-6399

Tel 425 882 8080  
Fax 425 936 7329  
<http://www.microsoft.com/>

**Microsoft**

September 19, 2001

Dell Computer  
Corporation  
Nicholas Wakou  
RR5  
One DellWay  
Round Rock, TX 787682

Nicholas:

Here is the information you requested regarding pricing for several Microsoft products to be used in conjunction with your TPC-C V5.0 benchmark testing.

All pricing shown is in US Dollars (\$).

Part Number	Description	Unit Price	Quantity	Price
810-00846	<b>SQL Server 2000 Enterprise Edition</b> <i>Per processor licensing</i> <i>Discount schedule: Open Program Level C</i>	\$ 16,541	4	\$ 66,164
C11-00821	<b>Windows 2000 Server</b> <i>Server license only - No CALs</i> <i>Discount schedule: Open Program - No Level</i>	\$ 738	1	\$ 738
C10-00475	<b>Windows 2000 Advanced Server</b> <i>Server license only - No CALs</i> <i>Discount schedule: Open Program - No Level</i>	\$ 2,399	1	\$ 2,399
048-00317	<b>Visual C++ Professional 6.0 Win32</b>	\$ 549	1	\$ 549
	<b>3-year maintenance for above software</b>	\$ 2,095	1	\$ 6,285

All products are currently orderable through Microsoft's normal distribution channels.

This quote is valid for the next 90 days.

If we can be of any further assistance, please contact Jamie Reding at (425) 703-0510 or [jamiere@microsoft.com](mailto:jamiere@microsoft.com).

Reference ID: Pelty0119090295

Please include this Reference ID in any correspondence regarding this price quote.